

Energy Recovery Wheel

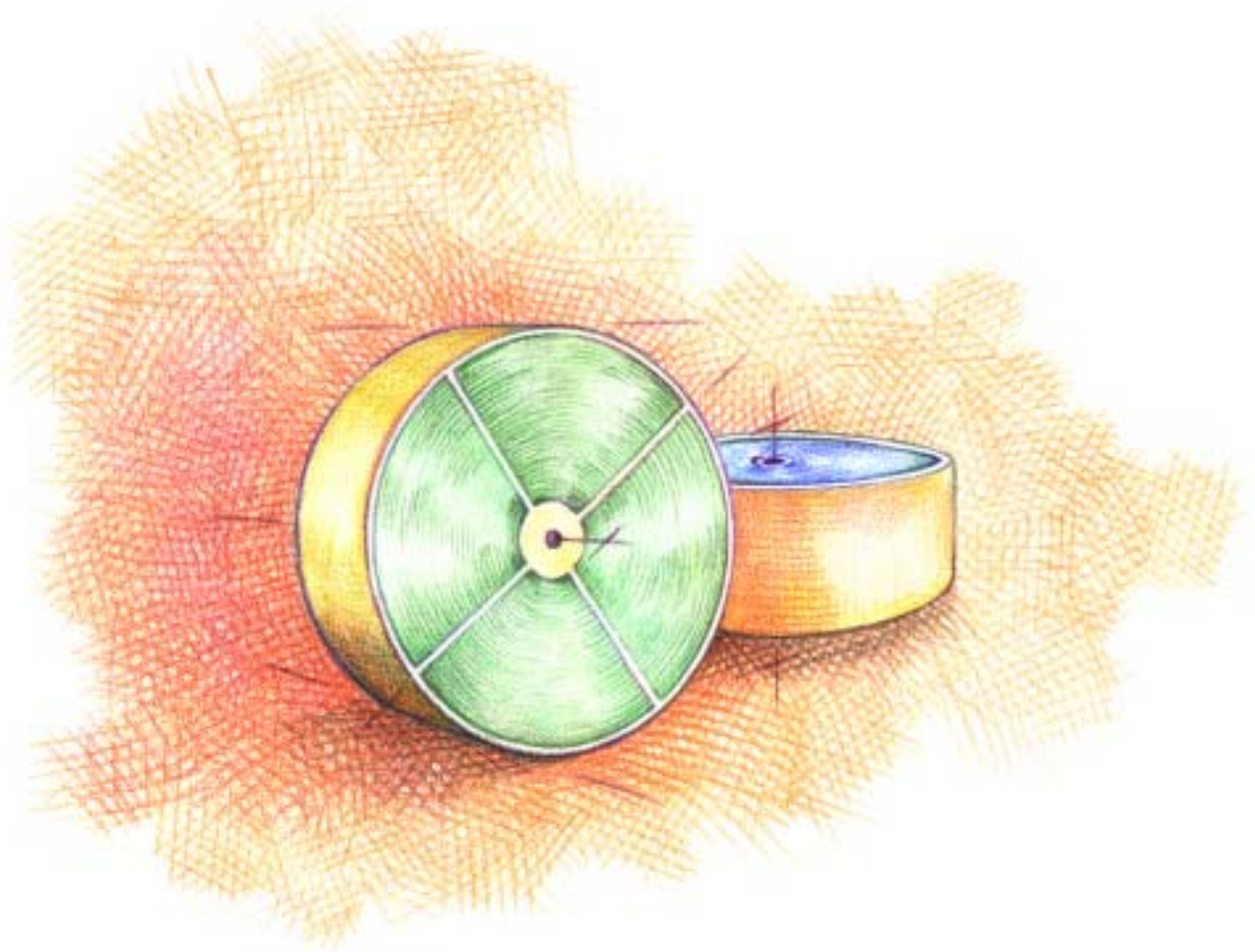

Technical Guide

Table of Contents

Introduction	1
The Ventilation Mandate	1
Typical Applications	2
Benefits	2
Design Features	3
Recovering Total Energy	6
Recovering Sensible Only	7
Unit Selection	8
Unit Selection Example	11
Purge Section	14
Fan Location Options	16
Drive Motor Location	16
Filtration Requirements	17
Odors and Contaminants	18
Wheel Speed Control	19
Preheating to Avoid Frost Formation	20
Controlling Wheel Speed To Avoid Frost Formation	20
Avoiding Overheating (Economizer Cycle)	21
Automatic Summer-Winter Change Over	21
Condensation on Sensible Only Wheels	21
Sensible Wheel Performance	22
Sensible Wheel Applications	23
Condensation & Frosting	23
Cleaning The Wheel Media	24
Installation Guidelines	24
Typical Wiring Schematic	25
Mounting Arrangements	26
Wheel Drive Options	26
Ordering Key	27
Performance Data for TE3 and TS Wheels	28
Unit Dimensions	28
Sample Specification	29
How to Reach SEMCO	30
Wheel Configuration Checklist	31
Psychrometric Chart	32

© SEMCO Incorporated 1990-2004. All rights reserved.

The information in this technical guide is furnished for informational use only, is subject to change without notice, and should not be construed as a commitment by SEMCO Incorporated. SEMCO Incorporated assumes no responsibility for any errors that may appear in this technical guide.

No part of this publication may be reproduced, stored in a retrieval system or transmitted, in any form or by any means, electronic, mechanical, recording, or otherwise, without the prior written permission of SEMCO Incorporated.

U.S. patented technology: 5,401,706 ; 5,496,397 ; 4,769,053

EXCLU-SIEVE, SEMCO, and the SEMCO logo are registered trademarks of SEMCO Incorporated.

Introduction

This design manual presents the SEMCO EXCLU-SIEVE® total energy (TE³) and sensible only (TS) recovery wheels. It explains features and benefits provided by this technology, provides a detailed selection procedure and reviews specific guidelines to assure an effective system design. This material should be reviewed carefully before beginning the design process.

Please contact your local SEMCO sales representative for additional design support or to answer any technical questions, which go beyond the scope of this brochure. You will find a listing of SEMCO sales representatives on our website. Please point your browser to www.semcoinc.com. You can reach SEMCO Incorporated on our toll free line at 888-473-6264.

The Ventilation Mandate

ASHRAE Standard 62, Ventilation for Acceptable Indoor Air Quality, defines the minimum outdoor air ventilation rates required to achieve acceptable indoor air quality. This standard, which is referenced in part or whole by all building codes in the United States, recommends that outdoor air quantities be increased from 5 cfm per person to 20 cfm per person (in an office environment) to avoid adverse health effects. Although most owners, architects and engineers recognize the benefits of bringing in more outdoor air, many are concerned about the impact on equipment and operating costs.

EXCLU-SIEVE provides the solution to the ASHRAE 62 mandate. It pre-cools and dehumidifies the outdoor air during the cooling season and preheats and humidifies the outdoor air during the heating season. As a result, the outdoor air quantity can be increased from 5 to 20 cfm per person without increasing energy costs.

As importantly, the first cost savings associated with the reduction in chiller and heating/humidification capacity typically pay for the added cost associated with the installation of the total energy recovery equipment.

As shown in Figure 1, significant reductions in the heating/cooling plant capacity can be recognized through the application of total energy recovery.

Figure 1. Savings potential with EXCLU-SIEVE® technology when increasing the ventilation air amount from 5 cfm/person to 20 cfm/person.

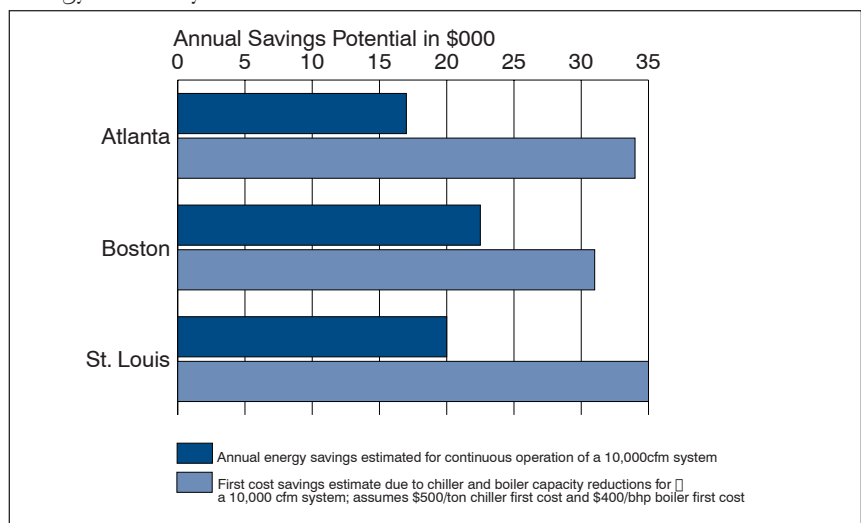

Typical Applications

Energy recovery equipment can be applied to a wide variety of applications:

- Schools, universities, dormitories;
- Offices, condominiums, apartments;
- Smoking lounges, casinos;
- Hospitals, nursing homes, day care centers;
- Hotels, motels, department stores;
- Clean rooms, circuit board, chip manufacturing;
- Breweries;
- Swimming pools, sports arenas;
- Convention centers, airports, prisons;
- Bus and train maintenance facilities;
- Welding, foundry, casting areas;
- Printing operations;
- All humidity controlled spaces; and
- Product drying operations.

Benefits

The SEMCO EXCLU-SIEVE technology affords a number of benefits:

- Independently certified wheel performance.
- Equal latent and sensible heat transfer.
- Highest effectiveness for given size equipment.
- Virtually no cross-contamination (independently certified to be less than 0.04 percent).
- Field adjustable purge section.
- Wheel independently certified to pass NFPA 90A requirements for flame spread and smoke generation based upon ASTM E84 fire test method.
- Reliable operation.
- Low maintenance.
- Low operating costs.
- Long life expectancy.
- Can be applied where stationary heat exchangers cannot.

Design Features

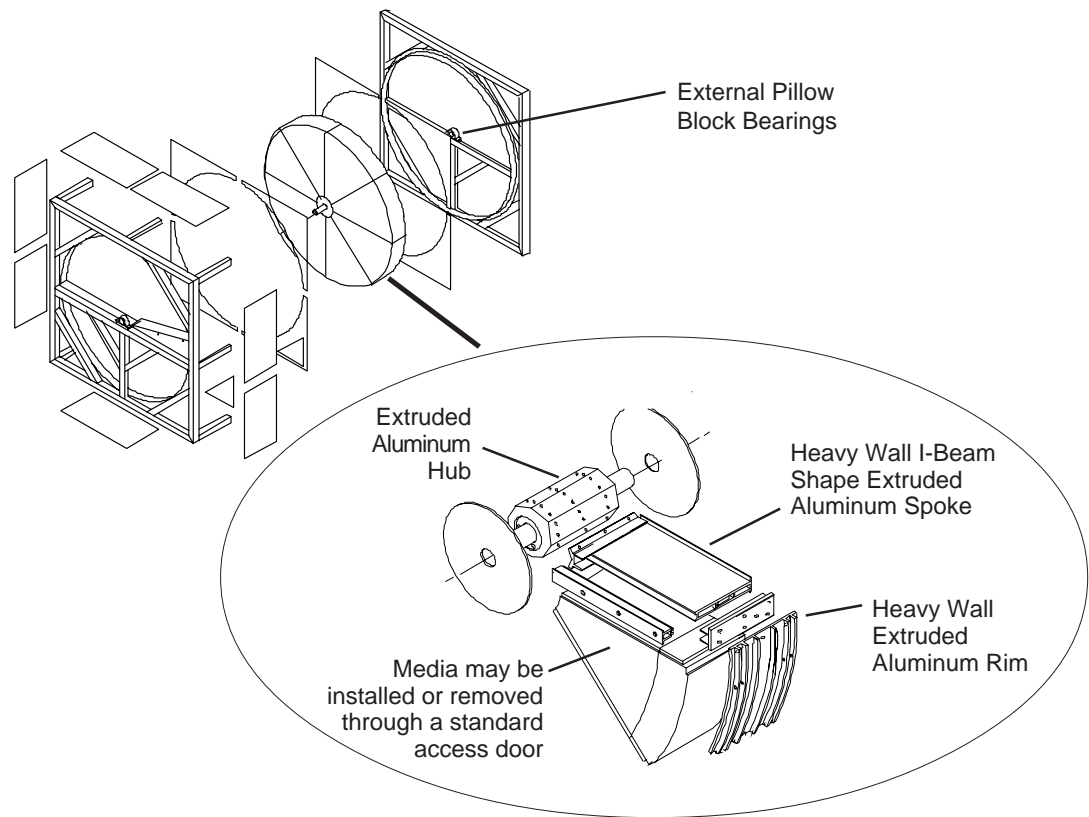

Hub & Spoke Construction Detail

Recovery Effectiveness (in %)		
Velocity (fpm)	EXCLU-SIEVE®	Competition
400	86.0	81.0
600	80.5	75.5
800	77.0	70.5
1000	74.5	66.0
Pressure Loss (in in. w.g.)		
Velocity (fpm)	EXCLU-SIEVE®	Competition
400	0.37	0.45
600	0.56	0.66
800	0.79	0.89
1000	1.05	1.15

Table 1. Comparison of SEMCO's EXCLU-SIEVE wheel performance with published data by competitors.

Superior Certified Performance Allows Compact Design

The performance data published for the EXCLU-SIEVE Energy Wheel is independently certified in accordance with ASHRAE 84-78P and is far superior to all other air-to-air energy recovery systems.

A unique flute design, coupled with numerous other design innovations, provides for the highest possible heat transfer characteristics while simultaneously reducing pressure loss parameters. These combined features optimize the "sensible" (temperature) recovery portion of the performance.

Providing "latent" (moisture) recovery efficiencies that match the improved sensible values is made possible by EXCLU-SIEVE's 3Å molecular sieve desiccant coating. The "rate of adsorption" by this transfer surface is more than twice that of other desiccants. This allows for effective moisture transfer from the high velocity airstreams inherent in energy recovery applications.

EXCLU-SIEVE's performance advantage is best shown by the comparison chart in Table 1. Notice that EXCLU-SIEVE has a better performance than the competition for a given face velocity. The higher effectiveness at a lower pressure drop maximizes savings.

3Å Molecular Sieve Desiccant Coating

The EXCLU-SIEVE wheel utilizes a 3Å molecular sieve desiccant coating to limit the risk of desiccant cross-contamination, which would otherwise cause a portion of the exhaust air pollutants to be transferred, along with the water vapor, to the fresh air stream.

The 3Å molecular sieve material utilized by SEMCO was developed specifically for “selective adsorption” and has been successfully used for decades by the petrochemical industry. Other desiccants like silica gel and oxidized aluminum cannot provide selective adsorption.

Molecular sieves are structurally stable, chemically inert and have a strong affinity for water vapor. This strong affinity for water vapor produces the high rate of adsorption, which provides superior latent transfer performance.

Non-oxidized Coated Media Construction

The EXCLU-SIEVE media is made from aluminum which is evenly coated, prior to being formed into its honeycomb configuration, with a dense layer of corrosion resistant desiccant. This extends the life of the aluminum media substrate and enhances its structural integrity. This is in sharp contrast to most other total energy wheels which are produced by oxidizing the surface of the aluminum substrate to form a crude desiccant, leaving the product susceptible to further oxidation and diminishes its structural integrity.

Modular Media Sections with Aluminum Spoke Support System

The media support system is made from aluminum extrusions. This provides the substantial structural backbone required to withstand the forces encountered during a wheel's 10,000,000 annual revolutions (assuming continuous operation).

The use of aluminum drastically reduces the weight of the rotor when compared to a steel support system. The result is a more evenly balanced rotor, which reduces wear and tear on the drive system and bearings.

The tolerances obtainable from an extruded media support structure allow for the flattest possible sealing surface. This adds significantly to the integrity of the total sealing system.

Service Free Drive and Control System

A responsive and maintenance-free drive system is an integral part of any rotary heat exchanger. The drive system standard with any EXCLU-SIEVE unit is an AC constant or variable speed system with drive belts.

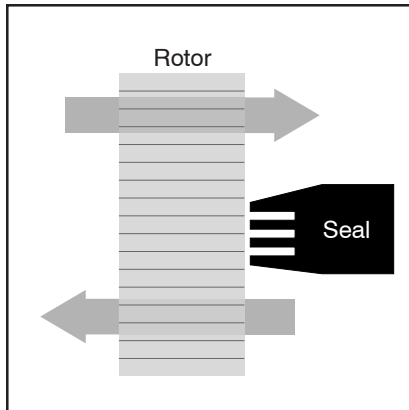

Air flowing between the rotor and labyrinth seal expands repeatedly, creating a pressure loss that forms an effective seal and prevents air from bypassing the rotor. The labyrinth seal never touches the rotor.

Non-wearing Extruded Labyrinth Seals

EXCLU-SIEVE utilizes a four-pass labyrinth seal, which has been designed to give optimum performance under the pressure conditions encountered in this application. Since the seals never actually touch the rotating surface, their life is indefinite. All seals are easily field adjustable. This efficient sealing system increases performance and virtually eliminates carryover of contaminants from the return air stream to the supply air stream.

Tubular Steel Casing Construction

To avoid deflection of the energy wheel casing due to the significant torque imposed by the air pressure on the energy wheel surface, a tubular steel framework is used. Casing deflection is undesired since it increases the gap between the seals and the wheel surface causing excessive air leakage.

Built-in Bearing Replacement System

The bearings used in the EXCLU-SIEVE units provide a long life with minimal maintenance. The external pillow block bearings simplify any replacements should this ever become necessary. The rotor remains in the casing and none of the rotor or media has to be removed.

Optional Extended Service Contract

The EXCLU-SIEVE units are designed to provide long and reliable operation. As a statement of our commitment to quality, the EXCLU-SIEVE wheels are available with an optional extended service contract to cover any unforeseen mechanical deficiencies or performance degradations. The coverage period can be as long as five years.

Complete details can be obtained from your local SEMCO sales representative.

Recovering "Total Energy"

SEMCO EXCLU-SIEVE enthalpy exchanger recovers both sensible (temperature) and latent (moisture) energy, and does so far more effectively than other competitive offerings.

This performance edge is a result of EXCLU-SIEVE's unique transfer core. This "honeycomb like" media utilizes an aluminum substrate coated with a fast acting, 3Å molecular sieve desiccant.

As the transfer core slowly rotates between the outdoor and return air stream, the higher temperature air stream gives up its sensible energy to the aluminum. This energy is then transferred to the cooler air stream during the second half of the revolution.

Just as the temperature is captured and released, so is the moisture (latent energy.) This is accomplished by the desiccant coating of the wheel. The desiccant has a very strong affinity for water and an enormous internal surface area to bind the water on its surface. Since the opposing airstreams have different temperatures and moisture contents, their vapor pressures on their surfaces differ. This vapor pressure differential is the driving force necessary for the transfer of water vapor (See Figure 2.)

The ability to recover latent energy is one of the major benefits of SEMCO's EXCLU-SIEVE technology. It will do this both in the cooling and the heating season. During the cooling season the outdoor air is dehumidified and pre-cooled. (See Figure 2.) This significantly reduces the cooling requirements of the conditioned space. In the heating season, the process reverses and the outdoor air is humidified and preheated. This reduces the costly humidification of ventilation air as well as the heating requirements of the indoor space.

Latent recovery doubles the energy savings potential recognized with the use of the sensible-only technology. It allows for cuts in chiller and boiler capacities. System designs incorporating total energy recovery are first cost equivalent to conventional designs when achieving the same ventilation requirements and supply air conditions. In addition, they provide operating cost savings year-in and year-out.

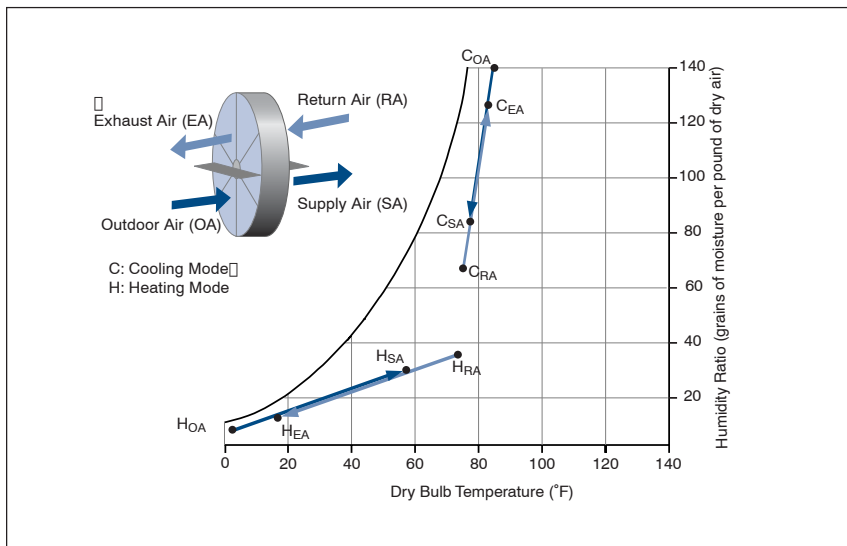

Figure 2. Typical operating conditions encountered in the cooling and heating mode of a total energy recovery unit.

Recovering "Sensible Only"

The SEMCO TS series of sensible only energy wheels is specifically designed to recover temperature only. The transfer media is not desiccant coated but is polymer coated to avoid oxidation over time. Oxidation reduces the structural integrity of the media over time and can also cause modest latent transfer which is usually undesirable in sensible only applications (please see "Sensible Wheel Applications" on page 23 of this brochure).

As shown in *Figure 3*, the air streams entering and leaving the sensible only wheel are heated or cooled. Since no latent recovery is accomplished, the moisture content of each airstream remains the same. A comparison of the processes in *Figures 2 and 3* reveals two key advantages offered by total energy recovery. First, the total energy wheel recovers far more energy due to the latent component. Second, the sensible wheel will approach moisture saturation far more easily in the heating mode. This can cause frost formation.

For these reasons, sensible wheels should only be used in applications where moisture transfer is undesirable. Examples of such applications include indirect evaporative cooling systems, desiccant cooling systems and reheat wheels as used in the SEMCO Fresh Air Dehumidification. In every other way the SEMCO TS wheel is similar to the EXCLU-SIEVE wheel and shares the benefits of superior performance and compact design.

Figure 3. Typical operating conditions encountered in the cooling and heating mode of a sensible only energy recovery unit.

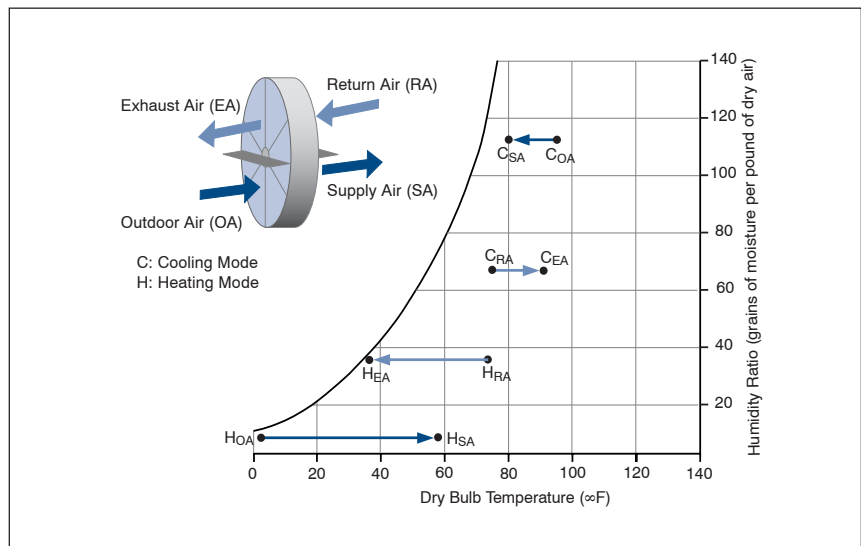

Unit Selection

1 Wheel Selection

Wheel selection is based on face velocity. The energy recovery wheel has been optimized for a face velocity of about 800. This achieves the best balance between energy recovery effectiveness, pressure loss and first cost.

Using the EXCLU-SIEVE Performance Chart (See *Figure 4*), find the desired airflow volume on the left hand margin of the performance chart. Selection is always based on the smaller of the supply or return airflow when using unequal airflows. Read across until intersecting the appropriate EXCLU-SIEVE TE3 model number, then read down to obtain the face velocity. Reading down the chart further will give the associated pressure loss for this face velocity. This procedure must be repeated at the larger airflow volume to determine the pressure loss for the opposite air stream in unequal flow applications.

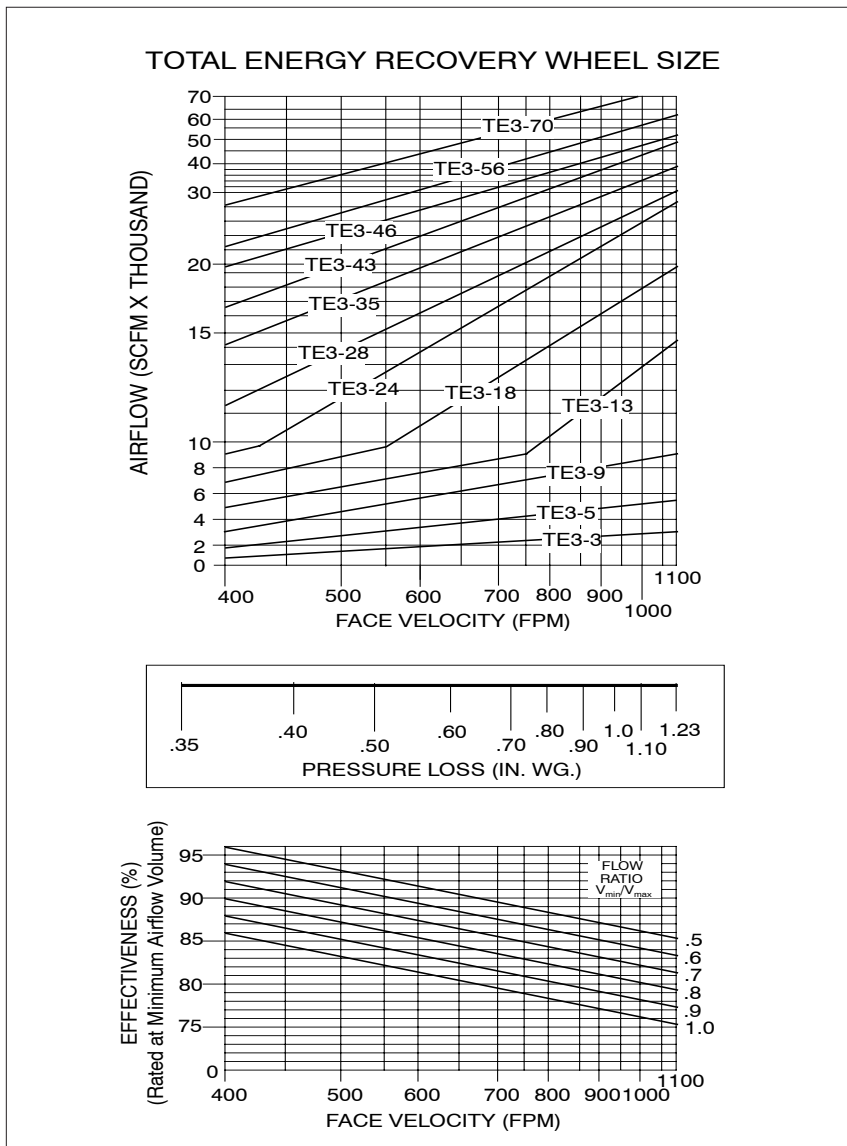

Figure 4. Performance charts for TE3 Series Total Energy Recovery Wheels.

2 Unit Effectiveness

To calculate the supply and exhaust air conditions leaving the module, the ASHRAE defined “unit effectiveness” must be determined as shown in *Figure 5*.

Since the supply and exhaust air quantities often differ, the unit effectiveness and the airflow ratio must be used in order to find the efficiency (the amount of temperature or moisture transferred) for both the supply and return air streams.

Figure 5. Definition of exchanger heat transfer effectiveness.

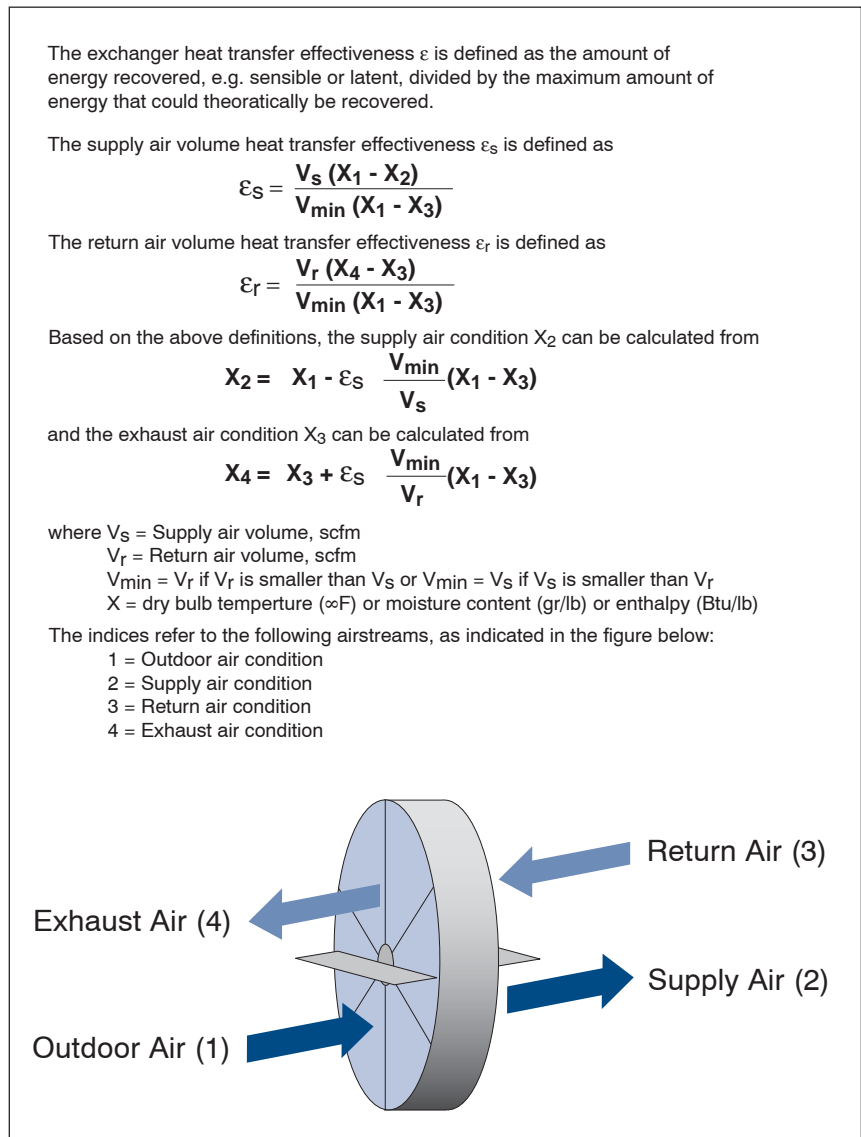

3 Unit Performance

Once the unit effectiveness is known, the equations provided by *Figure 5* are used to calculate the dry bulb temperature (T_{db}), moisture content (w) and enthalpy (h) conditions leaving the exchanger.

NOTE: Wet bulb temperatures cannot be substituted for grains or pounds of moisture per pound of dry air.

Exhaust Air Conditions

In most cases, the supply air leaving condition (as shown above) will be required for both the heating and cooling modes. In many cases, the exhaust air conditions must be calculated as well. This is required for applications in colder climates, where ambient temperatures fall below 15°F and where condensation and frost may form. (See *page 19*, “*Avoiding Frost and Condensation*”.)

4 Purge Volume

A purge section is utilized to avoid carry-over of exhaust air into the supply air stream. A small portion of outdoor air, in addition to that required for space conditioning, is required for purge operation. *Figure 8 on page 15* will provide the quantity of purge air required by your application. This air volume must be added to the capacity of the appropriate system fan(s) as shown by *Figure 9* (indicated as V_p).

5 Chiller & Boiler Reduction

The SEMCO total energy recovery wheel reduces the energy required to heat, cool and humidify the outdoor air volume to the return air condition by as much as 90 percent. This results from its ability to recover both latent and sensible energy at unprecedented efficiency levels.

This reduction in required chiller and/or boiler capacity should be carefully evaluated when making final unit selections since even a modest cut in the mechanical plant will offset the cost of the SEMCO total energy recovery wheel.

Utilizing the equations provided below, the potential chiller and boiler reduction can be estimated as follows.

$$\text{Chiller Capacity} = \{\text{supply air volume}\} (\text{Enthalpy}_{IN} - \text{Enthalpy}_{OUT}) \frac{4.5}{12,000} \text{ in tons of cooling}$$

$$\text{Boiler Capacity} = \{\text{supply air volume}\} (\text{Enthalpy}_{IN} - \text{Enthalpy}_{OUT}) \frac{4.5}{33,000} \text{ in boiler horse power}$$

The actual reduction made in the mechanical plant capacity, as compared to the potential reduction as determined above, will change from project to project. Factors such as weather data, hours of operation and multiple modules on the project and the need for redundant capacity must be carefully considered.

Unit Selection Example

Consider an example with design conditions presented in Table 2. This design data is the 0.4 percent wet bulb/mean coincident dry bulb data for St. Louis, Missouri as published in the ASHRAE 2001 Fundamentals Handbook, page 27.62.

Table 2. Example wheel selection design data.

Design Data	Cooling		Heating	
Supply Air Flow	12,000	scfm	12,000	scfm
Return Air Flow	10,800	scfm	10,800	scfm
Outdoor Air Conditions:				
Temperature	90	°F	2	°F
Moisture Content	133	gr/lb	4	gr/lb
Enthalpy	45.2	Btu/lb	1.1	Btu/lb
Return Air Conditions:				
Temperature	75	°F	70	°F
Moisture Content	64	gr/lb	43	gr/lb
Enthalpy	28.0	Btu/lb	23.5	Btu/lb
Purge Pressure Difference	3.0	in. w.g.	3.0	in. w.g.

1 Wheel Selection

Wheel selection is based on face velocity and the smaller of the return or supply airflow rates. Based on the return airflow rate of 10,800 scfm, the initial wheel size selected is TE3-13.

Figure 6 shows the basic selection procedure using the performance chart. The first step is to find the return airflow volume value of 10.8 (corresponding to 10,800 scfm). Drawing a straight line across the graph, we find that a TE3-13 wheel is sized for the optimal velocity between 700 and 900 fpm. Drawing a straight line from the intersection of the 10.8 line and the TE3-13 performance line, we read an approximate velocity of 840 fpm through the wheel.

We can check this value by calculating it from the dimensional data table on page 28. The flow area per face of the TE3-13 wheel is listed to be 13.1 ft². Thus, the return air volume of 10,800 scfm provides a face velocity of $10,800 / 13.1 = 840$ ft/min.

By extending the line from the face velocity axis to the pressure loss scale, we find the pressure loss to be about 0.87 in.wg.

2 Determine Effectiveness

To determine unit effectiveness, we first calculate the airflow ratio. This is the smaller of the supply or return air volumes divided by the larger of the two. In this example, the airflow ratio is $10,800 / 12,000$ or 0.9.

Once again, using the minimum airflow quantity, enter the performance chart (See Figure 6), traverse to the right until intersecting the desired model number, then read down until reaching the appropriate airflow ratio curve. Finally, traverse left until intersecting the result unit effectiveness value. For our example, the unit effectiveness is approximately 0.8.

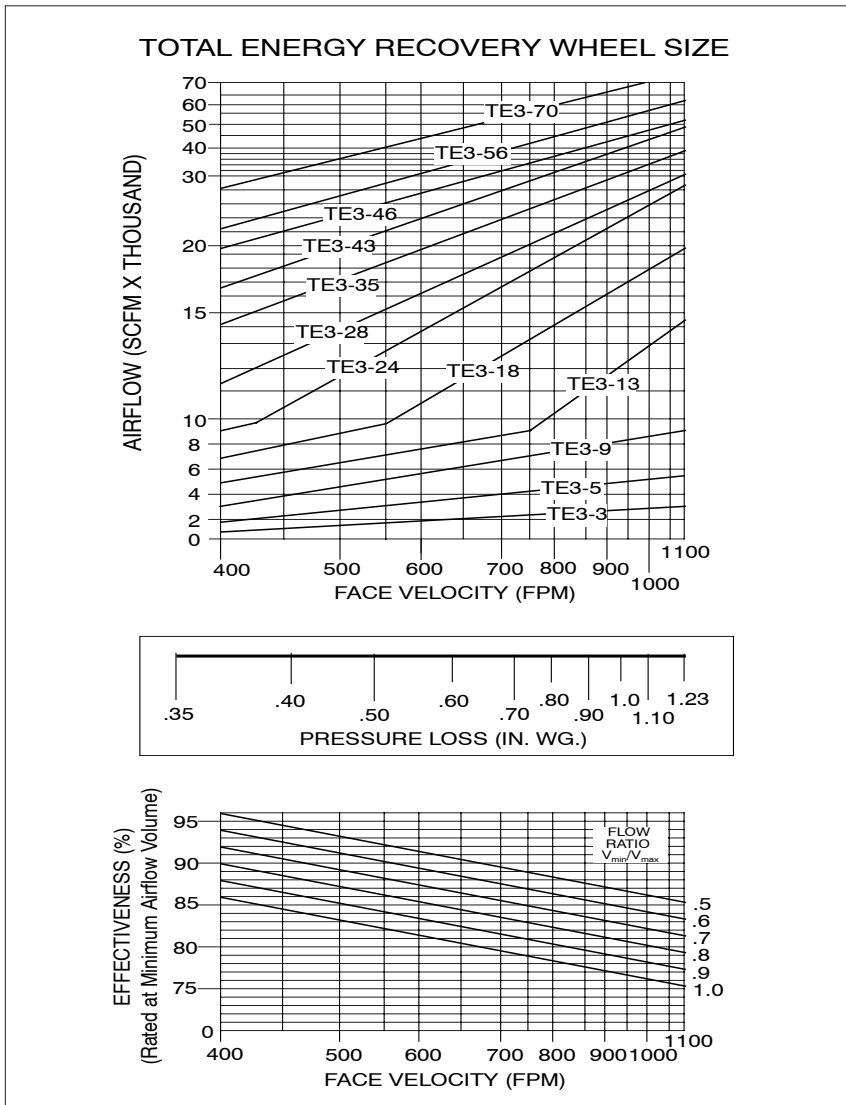

Figure 6. Using the EXCLU-SIEVE performance chart to select wheel size and determine pressure drop and wheel effectiveness.

3 Calculate Performance

Having determined the unit effectiveness to be 0.8, we can now calculate the supply air conditions for our example:

Supply Air Condition: Cooling Mode

$$X(T_{db})_2 = 90^{\circ}\text{F} - [.80 (10,800/12,000) (90^{\circ}\text{F} - 75^{\circ}\text{F})]$$

$$X(T_{db})_2 = \text{dry bulb temperature} = 79.2^{\circ}\text{F}$$

$$X(w)_2 = 133 \text{ gr/lb.} - [.80 (10,800/12,000) (133 - 64)]$$

$$X(w)_2 = \text{humidity ratio} = 83.3 \text{ gr/lb}$$

$$X(h)_2 = 43.5 \text{ Btu/lb} - [.80 (10,800/12,000) (43.5 - 28.0)]$$

$$X(h)_2 = \text{enthalpy} = 32.3 \text{ Btu/lb}$$

Supply Air Condition: Heating Mode

$$X(T_{db})_2 = 2^\circ\text{F} - [.80 (10,800/12,000) (2^\circ\text{F} - 70^\circ\text{F})]$$

$$X(T_{db})_2 = \text{dry bulb temperature} = 51.0^\circ\text{F}$$

$$X(w)_2 = 4 \text{ gr/lb} - [.80 (10,800/12,000) (4 - 43) \text{ gr/lb}]$$

$$X(w)_2 = \text{humidity ratio} = 32.1 \text{ gr/lb}$$

$$X(h)_2 = 1.1 \text{ Btu/lb} - [.80 (10,800/12,000) (1.1 - 23.5)]$$

$$X(h)_2 = \text{enthalpy} = 17.2 \text{ Btu/lb}$$

4 Determine Purge Volume

From Table 2 we know that the purge pressure difference is 3 in.wg. Using the procedure described on *page 15 and Figure 8*, we estimate the purge volume to be about 1,100 scfm.

5 Potential Chiller and Boiler Reduction

$$C = [12,000 \text{ scfm} \times 4.5 \times (43.5 - 32.3) \text{ Btu/lb}] / 12,000 \text{ btu/ton}$$

$$C = \text{Chiller reduction capacity} = 50.4 \text{ tons}$$

$$B = [12,000 \text{ scfm} \times 4.5 \times (17.2 - 1.1) \text{ btu/lb}] / 33,000 \text{ btu/bhp}$$

$$B = \text{Boiler reduction capacity} = 26.4 \text{ boiler h.p.}$$

Table 3 summarizes the results of our example.

Table 3. Calculated results of the EXCLU-SIEVE wheel selection example.

Calculated Design Data	Cooling	Heating
EXCLU-SIEVE Model	TE3-13	
Outdoor Air Face Velocity	1000 fpm	1000 fpm
Return Air Face Velocity	840 fpm	840 fpm
Unit Effectiveness	.80	.80
Supply Air Condition Dry Bulb Temperature Moisture Content Enthalpy	79.2 °F 83.3 gr/lb 32.3 Btu/lb	51.0 °F 32.1 gr/lb 17.2 Btu/lb
Exhaust Air Condition Dry Bulb Temperature Moisture Content	87.0 °F 119.2 gr/lb	15.6 °F 11.8 gr/lb
Supply Air Pressure Loss	1.0 in.wg.	1.0 in.wg.
Return Air Pressure Loss	.88 in.wg.	.88 in.wg.
Purge & Seal Volume	1,100 cfm	1,100 cfm
Purge Index Setting	4	4

Purge Section

Operation

As energy recovery wheel rotates from the exhaust air stream into the supply air stream, a small amount of the exhaust air is traversing the flutes of the wheel media as it passes by the seal separating the two air streams. If this volume of exhaust air were allowed to mix with the clean supply air stream, “cross-contamination” would occur.

Cross-contamination is virtually eliminated by a “purge section”, which is an integral part of the casing design. The purge section utilizes the pressure difference which exists between the outdoor and return air streams to “purge” the transfer media with clean outdoor air prior to its rotation into the supply air stream. *Figure 7* provides a graphic representation of the purge section operation.

The purge section is adjustable. This allows for optimizing the required purge volume during system startup, regardless of the pressure difference between the outdoor and return air streams (provided that the return air pressure is lower than that of the outdoor air).

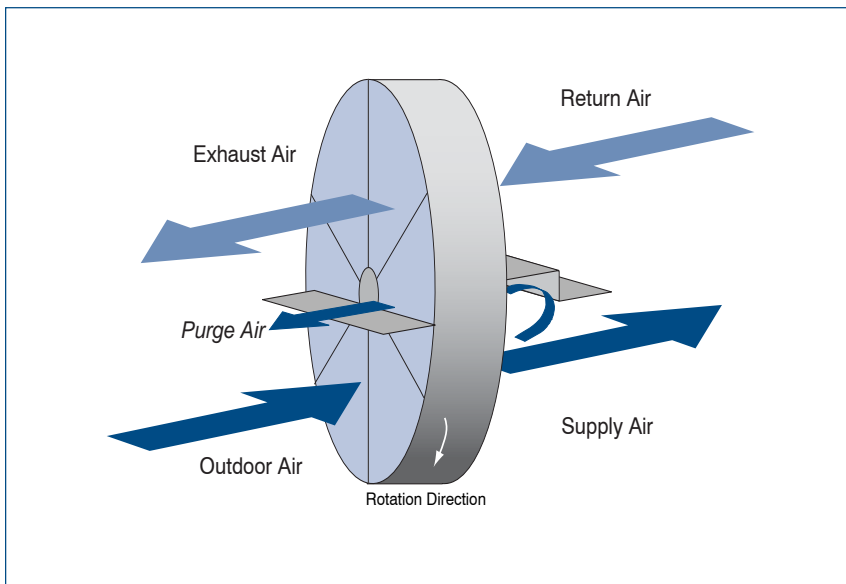

Figure 7. Schematic of the purge operation.

Selection

The required purge volume is determined by using the chart provided in *Figure 8*.

First, the wheel size and the estimated pressure difference between the outdoor and return air stream is determined. Traverse upward until intersecting the appropriate wheel size. Reading to the left at the intersection provides the air volume required for purge and seal leakage.

After determining the difference between the return and outdoor pressures, use *Table 4* to determine the correct purge index.

Figure 8. Chart to determine required purge volume, based on purge pressure and wheel size.

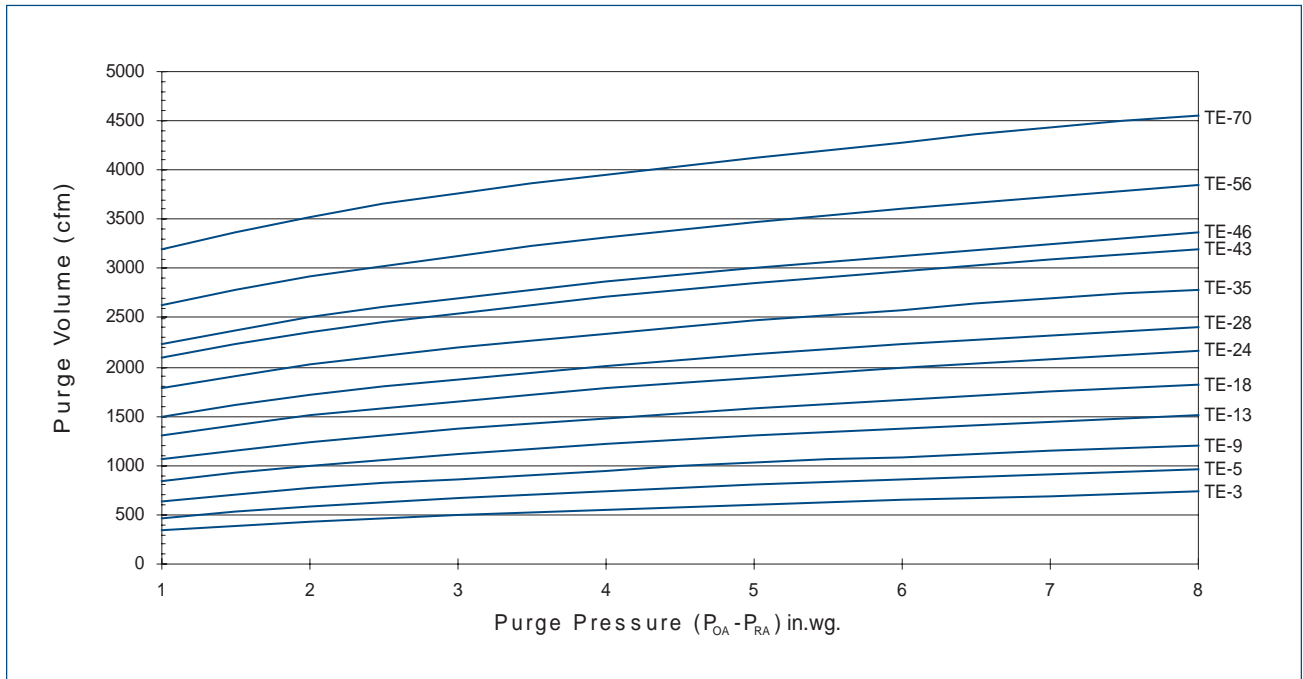

Table 4. Relationship between pressure difference and purge index.

Pressure Difference Range (in.wg.)	Purge Index Setting
0.00 - 0.99	Consult SEMCO
1.0 - 1.5	6
1.6 - 2.0	5
2.1 - 3.0	4
3.1 - 6.0	3
6.1 - 10.0	2
> 10.0	1

Fan Location Options

To assure effective purge operation and limit cross-contamination, the pressure of the return air stream must be lower than that of the outdoor air stream. As shown in *Figure 9*, three fan locations allow for effective purge operation. The fourth fan arrangement, draw-through supply and blow-through exhaust, must not be utilized if cross-contamination is of concern. In that arrangement the pressure of the exhaust side will always be greater than that of the return air and the purge section will not operate under such conditions.

The purge and seal leakage air volume must be added to the appropriate fan(s) depending on the fan arrangement. *Figure 9* shows which fans must be sized to handle this additional air volume (V_p) for the different fan arrangements.

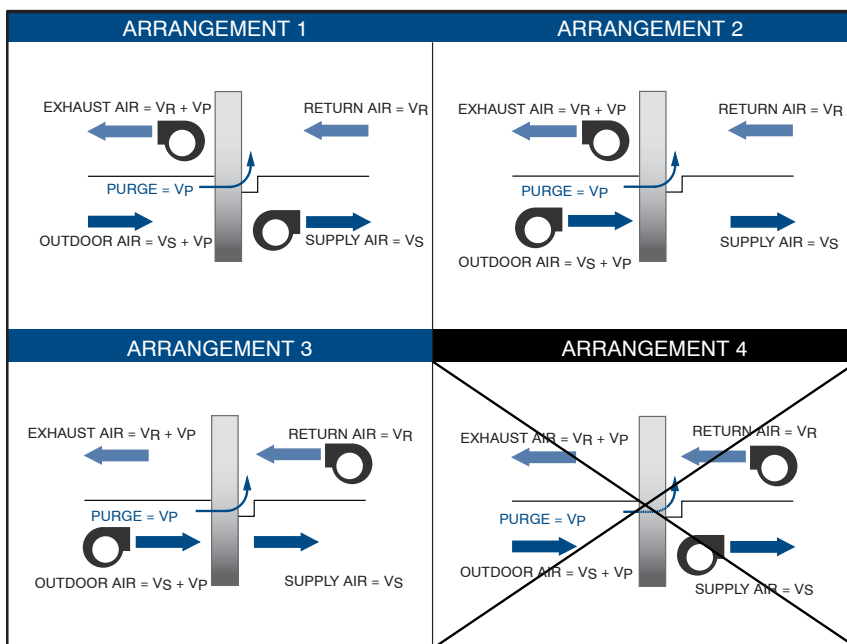

Figure 9. Fan arrangements for proper purge operation.

Drive Motor Location

The standard mounting location for the EXCLU-SIEVE drive motor is in the supply air stream. The motor is located in the lower right hand corner of the unit when looking at the conditioned air side.

Filtration Requirements

The EXCLU-SIEVE media is designed to induce laminar flow under all conditions. This results in a flow profile, which causes airborne particles smaller than approximately 800 microns, to pass freely through the rotor media (See Figure 10).

Self-Cleaning Feature

As the EXCLU-SIEVE rotor operates between two opposing air streams, the continuous reversal of airflow results in a very efficient “self-cleaning” process. This process is further enhanced by the very high velocity of the airflow in the purge section. As a result, only minimal filtration is required for efficient operation of the EXCLU-SIEVE unit under conditions encountered most typically in commercial and institutional buildings.

Figure 10. Comparison of laminar and turbulent flow profiles in the transfer media.

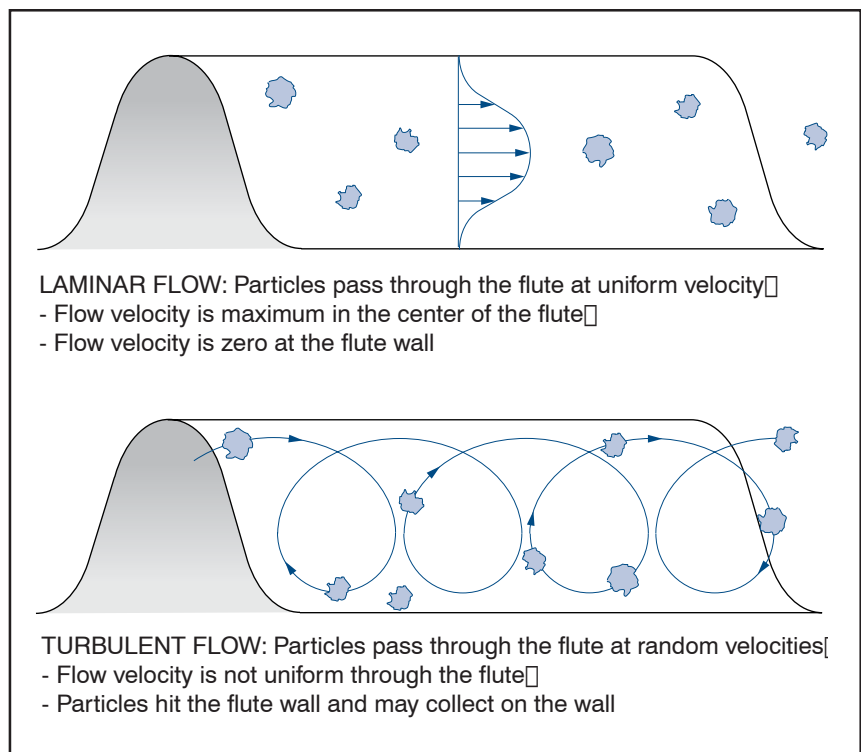

Outdoor and Supply Air streams

An insect screen should be placed behind the outdoor air intake louver in order to prohibit large items such as insects, leaves and debris from entering the EXCLU-SIEVE energy wheel. It is also recommended that low efficiency (20 - 30 percent), cleanable or pleated filters be provided prior to the EXCLU-SIEVE energy wheel.

Return Air stream

For applications where the return air is relatively clean (such as general office areas), no filtration is required prior to the EXCLU-SIEVE energy wheel. In industrial or institutional applications where the return air contains bacteria, lint, oil mist, or animal hair, the appropriate filtration must be incorporated. Please contact SEMCO Incorporated for specific recommendations.

Odors and Contaminants

The EXCLU-SIEVE product was specifically developed for applications involving contaminated air streams. Its field adjustable purge section and four pass non-wearing labyrinth sealing system limits “air stream cross-contamination” to less than .04 percent of the exhaust air concentration by volume.

“Selective adsorption,” the ability to transfer water vapor to and from the exhausted air stream while allowing other gaseous contaminants to pass unadsorbed, is a necessity for most all energy recovery applications. Re-circulating some portion of these contaminants back to the space is undesirable since it reduces the dilution ventilation efficiency (requiring more ventilation air), can cause buildup of odors and, in some applications, result in an unhealthy environment.

The EXCLU-SIEVE wheel provides selective adsorption through the application of a 3-angstrom molecular sieve desiccant material. Desiccants such as silica gel, activated alumina, oxidized aluminum, and even other types of molecular sieves, do not provide selective adsorption.

Adsorbents trap water vapor and/or other components within their complex internal surface area, which is comprised of a network of holes or “pores.” “Molecular sieves” are different than all other desiccants. Their “pore diameter” is completely uniform and in the case of a 3Å molecular sieve, it can be controlled to precisely 3 angstroms. This configuration excludes the adsorption of molecules that have a kinetic diameter greater than 3 angstroms (practically all contaminants) while having a strong affinity for and adsorbing water vapor (2.8 angstroms).

Pollutant Tested	Pollutant Concentration*	Measured Cross-Contamination
Isopropanol	20 ppm	None
Methyl-Isobutyl-Ketone	1840 ppb	None
Xylenes	7100 ppb	None
Carbon Dioxide	500 ppm	None
Propane	82 ppm	None
Sulfur Hexafluoride	212 ppm	None
Water Vapor	4000 ppm	80%
*Concentrations selected by GTRI to reflect worst case for typical application		

Table 5. A summary of independent testing conducted by the Georgia Tech Research Institute confirming the ability of the EXCLU-SIEVE wheel to avoid contaminant cross-contamination. For more information, request a copy of the GTRI cross-contamination report.

Wheel Speed Control

An important design advantage provided by rotary energy recovery technology is the ability to control performance by varying the rotational speed of the rotor media. EXCLU-SIEVE utilizes an A/C frequency inverter and temperature sensors to control the leaving air temperature during the various modes of operation.

Figure 11. Example of wheel speed modulation.

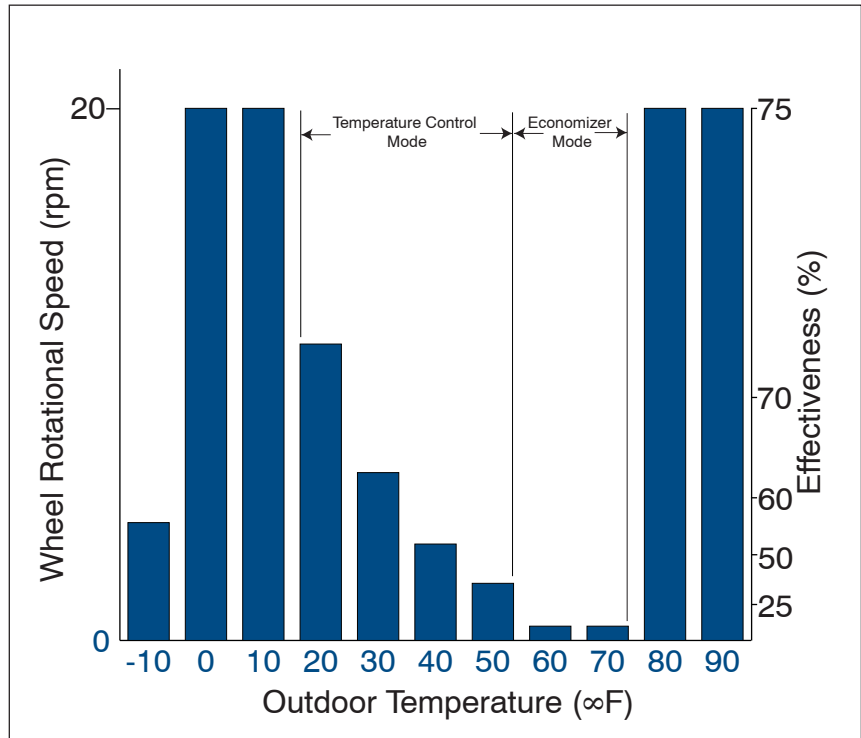

Avoiding Frost Formation and Condensation

For applications in extremely cold outdoor air conditions, the risk of frost formation should always be analyzed. EXCLU-SIEVE provides a significant advantage over sensible only recovery (temperature only) devices. It dehumidifies the exhaust air stream as it is cooled. This prohibits the exhaust air stream from reaching saturation under all but extreme conditions. If the saturation condition is avoided, frost will not form on the exchange surface.

Frosting can also be avoided during the extreme conditions by monitoring the exhaust air temperature and reducing the recovery effectiveness by the amount required to avoid saturation. Additionally, frosting can be avoided by preheating the outdoor air, heating the return air or bypassing the exchanger. Preheating or speed control are the most common methods.

Preheating to Avoid Frost Formation

Applications that involve humidity control during the heating season (above 30 percent relative humidity) and when the outdoor air temperature is frequently below 0°F, preheating the outdoor air to avoid frost formation is usually the most energy efficient approach. This is because the total energy wheel is allowed to operate at full recovery on very cold days, thereby providing for maximum humidification recovery. Reducing the wheel speed to cut temperature recovery also reduces the latent recovery.

The preheat temperature required is determined by:

1. Locating the return air condition on a psychrometric chart
2. Drawing a line tangent to the saturation curve
3. Connecting to the heating design outdoor air humidity content
4. Reading the dry bulb intercept value, as shown in *Figure 12*, line RA-OA₁
5. Preheating the outdoor air to the dry bulb intercept value, as shown by *Figure 12*, line OA₂-OA₁

Controlling Wheel Speed To Avoid Frost Formation

Applications where humidification is not provided during the heating season (below 30 percent RH during cold days) and where the number of hours below 0°F each year are few, varying wheel speed to avoid frost formation is probably the best choice.

The dew point control set-point is determined by:

1. Locating the return air condition (RA) that exists when the winter outdoor air design condition is reached.

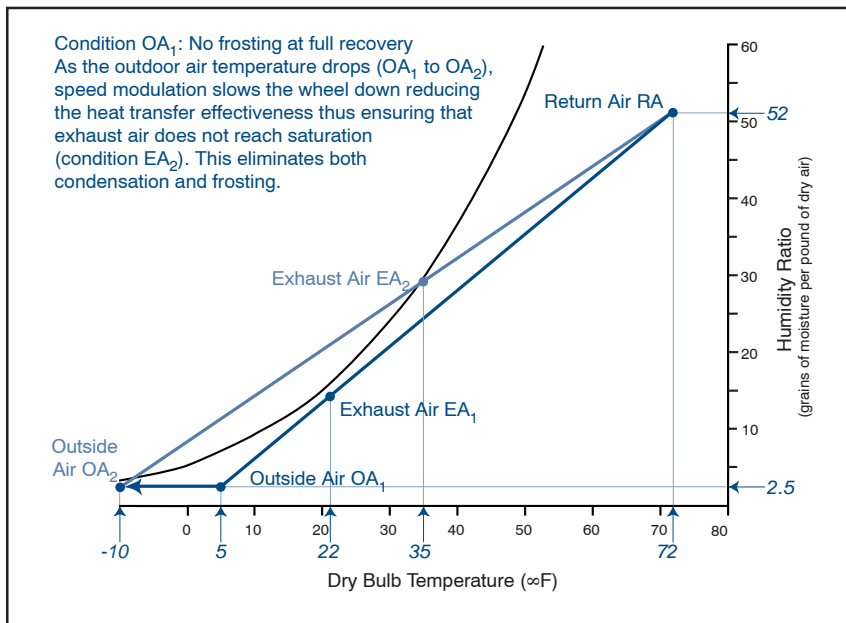

Figure 12. Example of preheat or wheel speed modulation to avoid frost formation.

2. Plot the RA point on the psychrometric chart and draw a line between it and the winter design point.
3. Determine the higher dry bulb temperature at which this line intercepts the saturation curve (EA_2 on *Figure 12*).
4. Add 2°F to this temperature and this becomes the control (winter) set-point.

Avoiding Overheating (Economizer Cycle)

During the Spring and Fall seasons, when the outdoor air temperature is close to that being supplied to the space, the EXCLU-SIEVE control system will slow the media rotational speed in response to a supply air set-point. This decreases the recovery effectiveness by the amount required to provide the desired supply air temperature (See *Figure 11*).

Automatic Summer-Winter Change Over

By monitoring the difference between the outdoor air condition and the return air condition, the cooling mode is selected whenever the outdoor air is warmer than the return air. This calls for full recovery effectiveness once again. Full recovery is maintained automatically until the outdoor air condition drops to the point where the economizer cycle is most efficient.

Condensation on Sensible Only Wheels

Variable wheel speed and reheat approaches can be used for sensible energy wheels. Consult SEMCO Incorporated for assistance.

Sensible Wheel Performance

The performance chart shown below presents the performance for the SEMCOTS series of sensible (temperature transfer only) energy recovery wheels. This performance chart would be utilized along with the selection procedure, outlined on pages 8 through 10 of this brochure for selection of a TE3 series total energy (temperature and moisture transfer) wheel, to calculate supply and exhaust air efficiencies, dry bulb temperature conditions and pressure loss data. Since sensible only wheels are not designed to transfer moisture, the supply and exhaust air humidity content is equal to that of the outdoor and return airstreams respectively. Some moisture will be transferred if condensation occurs on the surface of the TS wheel and this situation should be avoided in most cases (See "Condensation and Frosting").

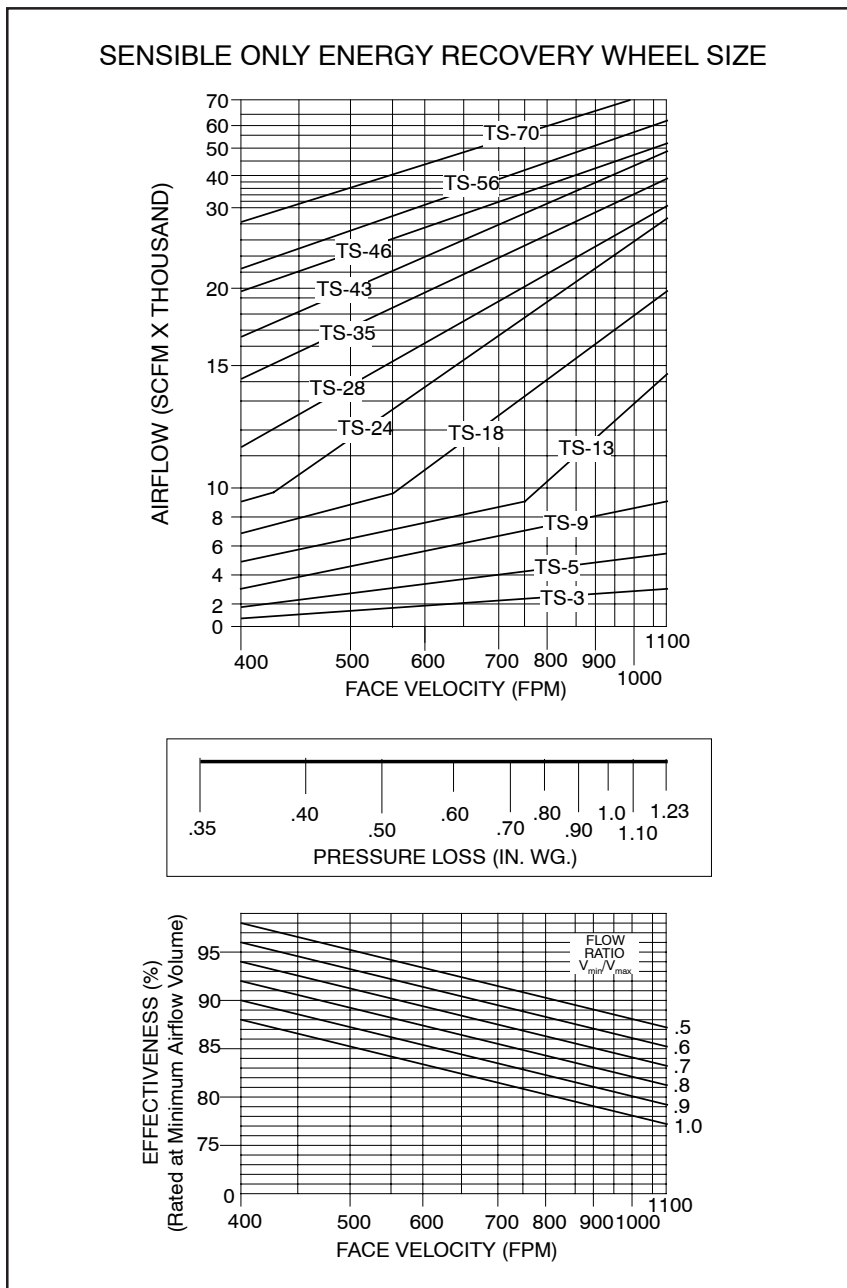

Figure 13. Performance charts for TS series sensible only recovery wheels.

Sensible Wheel Applications

Sensible wheels should only be applied to applications where the transfer of moisture is undesirable. This is due to the fact that the EXCLU-SIEVE total energy wheel is approximately the same cost, but offers the advantage of latent recovery and the associated frost control advantage, which makes it the product of choice for even heating mode only applications.

Examples of sensible only applications include indirect evaporative cooling, direct/indirect evaporative cooling, desiccant based cooling (second wheel) and in the reheat position in the SEMCO EPD system concept.

The common element for all of these applications is the importance of avoiding any moisture transfer. To avoid moisture transfer, it is critical that the aluminum wheel media be carefully coated to avoid the inherent oxidation that would otherwise take place over time, turning a sensible wheel into a moderately effective latent wheel. As a result, all SEMCO TS sensible only wheels are made from a polymer coated aluminum substrate, which is carefully coated prior to being formed into the honeycomb transfer media.

Condensation & Frosting

Unlike the EXCLU-SIEVE total energy wheel where the supply air leaving the wheel follows a straight path between the return air and the outdoor air, a plot of the supply air condition leaving a sensible only wheel on a psychrometric chart resembles that of a chilled water coil. Since no moisture is transferred by a sensible wheel, the temperature of the air streams are changed as the sensible energy is exchanged, but the moisture level remains constant unless the supply air or exhaust airstreams are cooled to below their dew points.

If this occurs, one of three things will happen:

1. If the exhaust air stream is cooled to less than approximately 20°F below its dew point, and if the leaving temperature of the air stream is above 32°F, a thin film of condensate will form on the vast surfaces of the wheel media, and this condensate will re-evaporate into the warmed supply air stream. If this moisture transfer is a problem, it can best be avoided by limiting the exhaust side recovery with controls to vary wheel speed based on a dew point temperature sensor.
2. If the exhaust air stream is cooled more than 20°F below its dew point, and if the leaving temperature of the air stream is above 32°F, some condensate will re-evaporate into the warmed supply air stream and the remainder will blow off of the wheel surface. This is not advised and, as a result, the variable wheel speed controller should once again be applied.
3. If the exhaust air stream is cooled below 32°F and reaches its dew point, frost may form on the face of the wheel, reducing airflow. Preheat should be applied in this case to avoid cooling the exhaust air stream below its dew point.

Cleaning The Wheel Media

The SEMCO EXCLU-SIEVE energy recovery wheel has been designed so that a laminar flow is maintained within the transfer media at all operating conditions. This means that the air and all other particles in the air stream pass straight through the wheel.

Due to the laminar flow profile through the EXCLU-SIEVE energy wheel, any collection of dust or particulate matter will occur at the entering and leaving edges of the transfer media. Such buildup can usually be vacuumed, purged with compressed air or wiped from the rotor surface. In rare cases where a more thorough cleaning is required, low temperature steam or hot water and detergent may be used. Consult SEMCO for instructions when using cleaning methods other than compressed air or vacuuming.

Installation Guidelines

Provisions should be made to allow access to all four sides of the module to facilitate seal adjustment and routine inspection.

Locate the A/C inverter control panel in a dry, conditioned space, which is clearly visible to the operations personnel. A rotation detector should be included as a part of the control package for all critical applications.

The purge section must always face the conditioned airside of the system. Rotation is such that a spot on the media in the return air section would rotate towards the purge section without first passing into the supply section.

Carefully review the purge, fan location and filter recommendations covered by this brochure prior to completing any design. Select the appropriate control option for the application. Please consult SEMCO for any additional design assistance required.

Consult SEMCO for design recommendations with applications involving hazardous contaminants, exhaust air temperatures in excess of 180°F and/or high humidity conditions (drying ovens, swimming pools, etc.).

Typical Wiring Schematic

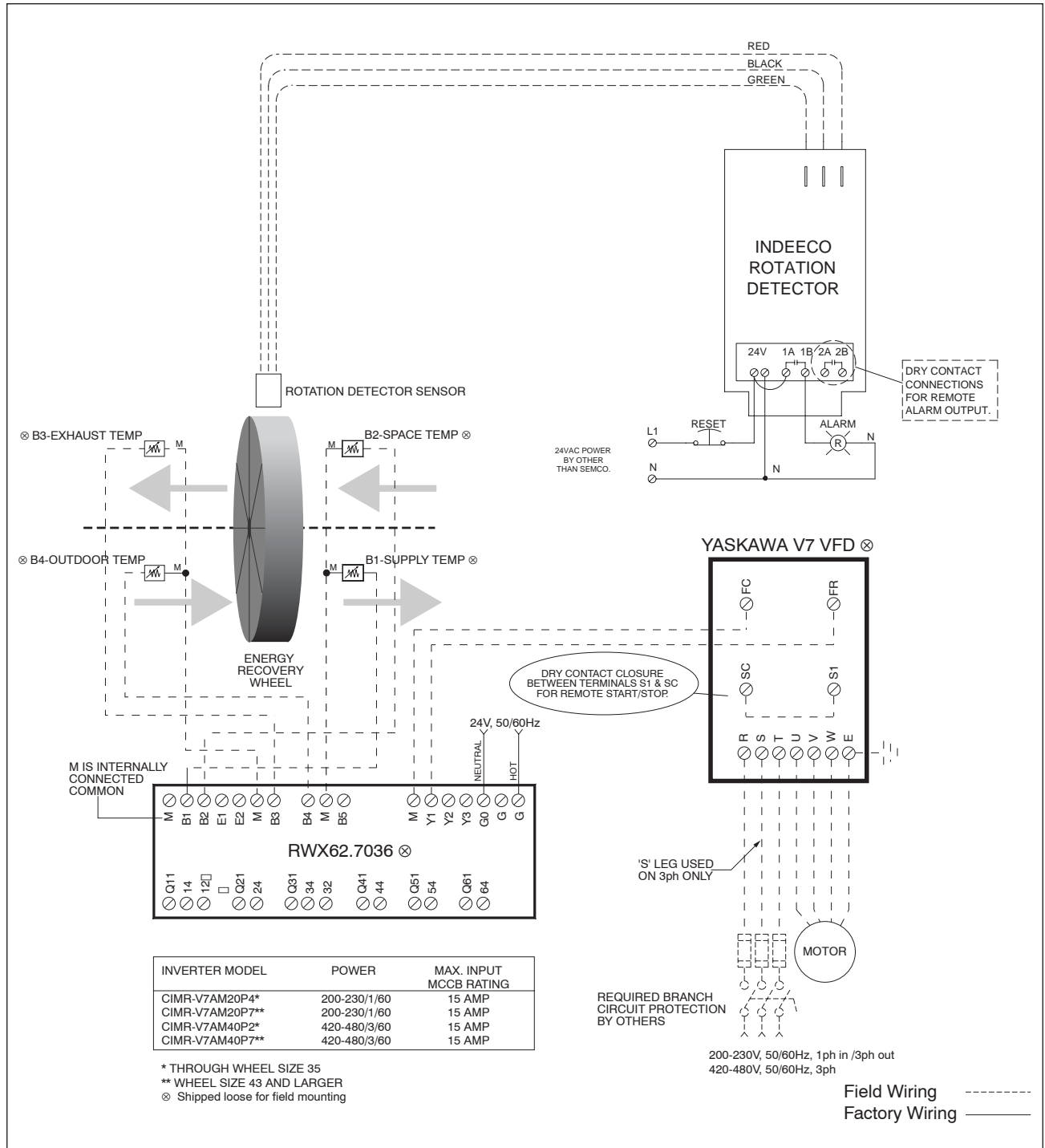

Mounting Arrangements

The EXCLU-SIEVE units can be mounted in six different positions (see *Figure 14*). The number of support points required for horizontal mounting may vary depending on the size of the unit. Consult SEMCO for support details.

When installing an EXCLU-SIEVE unit, the purge section must always face the conditioned airside of the system. Rotation is such that a spot on the media in the return air section would rotate towards the purge section without first passing into the supply section.

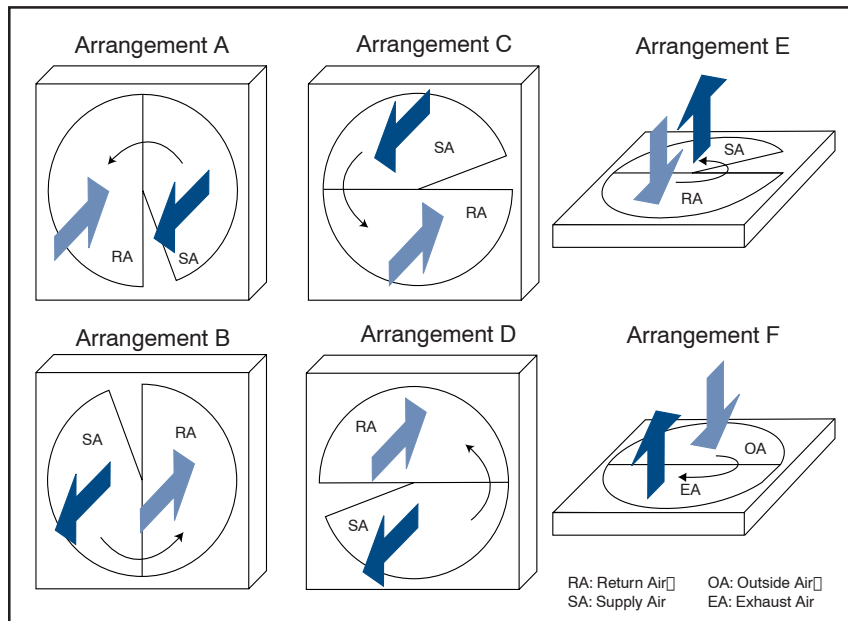

Figure 14. Wheel mounting arrangements.

Wheel Drive Options

There are three different control options that can be ordered with the Total Energy Recovery unit:

No Controls:

Power is connected directly to the motor. The wheel rotates at a constant speed (20 rpm).

Variable Frequency Drive (VFD) ONLY:

SEMCO ships a pre-qualified variable frequency drive with the unit for field mounting. The VFD has the same voltage as the motor and can modulate the motor from 20 rpm to 1/4 rpm. Four temperature sensors (one in each air stream), and a PCM must be field provided, mounted, wired and programmed.

Variable Frequency Drive (VFD) & Controls:

SEMCO ships the same variable frequency drive mentioned above, along with four temperature sensors and a solid-state controller with the module. All of these accessories are to be field mounted and wired. The advantage of this option is that it is a pre-packaged stand-alone system.

A rotation detector can be ordered with any of the control options mentioned above. This rotation detector will ship with the unit for field mounting.

Ordering Key

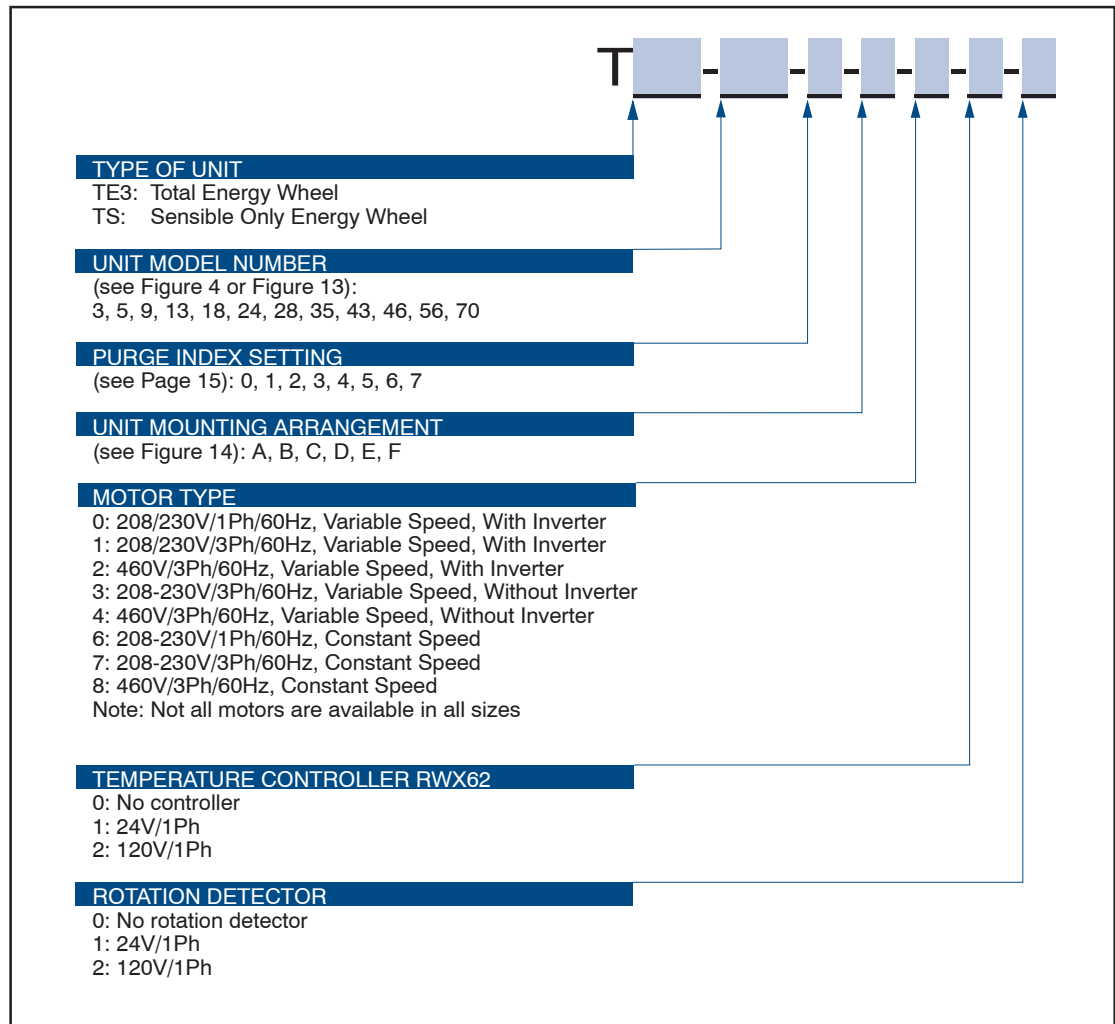

Performance Data For TE3 & TS Wheels

Velocity fpm	Efficiency %	Press. Drop in.wg	Airflow Rate (in cfm) ▼	Wheel Size											
				3	5	9	13	18	24	28	35	43	46	56	70
300	88.0	0.29		840	1,590	2,580	3,930	5,430	7,140	8,490	10,560	12,870	13,920	16,800	21,120
400	86.0	0.37		1,120	2,120	3,440	5,240	7,240	9,520	11,320	14,080	17,160	18,560	22,400	28,160
500	82.5	0.45		1,400	2,650	4,300	6,550	9,050	11,900	14,150	17,600	21,450	23,200	28,000	35,200
600	80.5	0.56		1,680	3,180	5,160	7,860	10,860	14,280	16,980	21,120	25,740	27,840	33,600	42,240
700	78.5	0.67		1,960	3,710	6,020	9,170	12,670	16,660	19,810	24,640	30,030	32,480	39,200	49,280
800	77.0	0.79		2,240	4,420	6,880	10,480	14,480	19,040	22,640	28,160	34,320	37,120	44,800	56,320
900	76.0	0.94		2,520	4,770	7,740	11,790	16,290	21,420	25,470	31,680	38,610	41,760	50,400	63,360
1000	74.5	1.05		2,800	5,300	8,600	13,100	18,100	23,800	28,300	35,200	42,900	46,400	56,000	70,400
1100	73.5	1.18		3,080	5,830	9,460	14,410	19,910	26,180	31,130	38,720	47,190	51,040	61,600	77,440

Unit Dimensions

Wheel Sizes 13 - 70

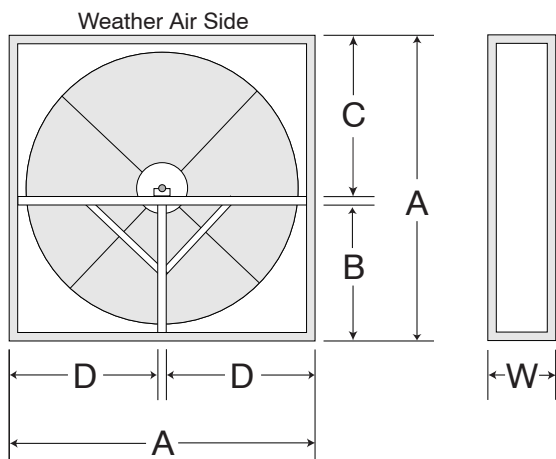

Wheel Sizes 3, 5, 9

Mounting Arrangements A, B, C, D, E, and F (see Figure 14)

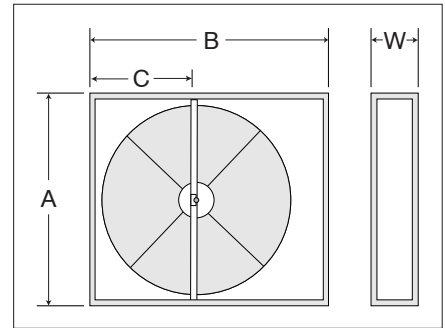

Wheel Size	A	B	C	W	Net Wt. (lbs)	Flow area/side ft ²	Nominal cfm
3	39.8	48.8	17.8	20.0	380	2.8	2,000
5	51.8	58.2	23.8	20.0	520	5.3	4,000
9	63.8	70.2	29.8	20.0	700	8.6	7,000

Wheel Size	A	B	C	D	W	Net Wt. (lbs)	Flow area /side, ft ²	Nominal cfm
13	75.8	33.3	40.5	36.9	21.0	1,070	13.1	10,500
18	87.8	39.3	46.5	42.9	21.0	1,300	18.1	15,500
24	99.8	45.3	52.5	48.9	21.0	1,640	23.8	19,000
28	111.8	49.3	59.5	54.4	23.0	2,640	28.3	22,500
35	123.8	55.3	65.5	60.4	23.0	3,000	35.2	28,000
43	135.8	61.3	71.5	66.4	23.0	3,390	42.9	34,000
46	141.0	63.9	74.1	69.0	23.0	3,570	46.2	37,000
56	154.0	70.4	80.6	75.5	23.0	4,030	56.0	45,000
70	171.5	79.1	89.4	84.3	23.0	4,680	70.4	56,000

All dimensions in inches

Sample Specification

A. Total Energy Recovery Wheel Unit - The rotor media shall be made of aluminum, which is coated to prohibit corrosion. All media surfaces shall be coated with a non-migrating solid adsorbent layer prior to being formed into the honeycomb media structure to ensure that all surfaces are coated and that adequate latent capacity is provided. The media shall have a flame spread of less than 25 and a smoke developed of less than 50 when rated in accordance with ASTM E87. In addition to the desiccant coating that is applied to the surfaces of the aluminum substrate, the two faces of the total energy recovery wheel shall be covered and sealed with a two part polymer heavy duty coating specifically chosen for chemical resistance.

The desiccant shall be inorganic and specifically developed for the selective adsorption of water vapor. The desiccant shall utilize a 3A molecular sieve certified by the manufacturer to have an internal pore diameter distribution which limits adsorption to materials not larger than the critical diameter of a water molecule (2.8 angstroms).

Submit certification by a qualified independent organization documenting equal sensible and latent recovery efficiencies conducted in accordance with ASHRAE 84-78P and the results presented in accordance with ARI 1060 standards.

An independent wheel test from a credible test laboratory shall document that the desiccant material utilized does not transfer pollutants typically encountered in the indoor air environment. The cross-contamination and performance certification reports shall be provided upon written request for engineering review.

Media Cleaning - The media shall be cleanable with low-pressure steam (less than 5 PSI), hot water or light detergent, without degrading the latent recovery. Dry particles up to 800 microns shall pass freely through the media.

Purge Sector - The unit shall be provided with a factory set, field adjustable purge sector designed to limit cross contamination to less than .04 percent of that of the exhaust air stream concentration when operated under appropriate conditions.

Rotor Seals - The rotor shall be supplied with labyrinth seals only, which at no time shall make contact with any rotating surface of the exchanger rotor face. These multi-pass seals shall utilize four labyrinth stages for optimum performance.

Rotor Support System - The rotor media shall be provided in segmented fashion to allow for field erection or replacement of one section at a time without requiring side access. The media shall be rigidly held in place by a structural spoke system made of extruded aluminum.

Rotor Housing - The rotor housing shall be a structural framework, which limits the deflection of the rotor due to air pressure loss to less than 1/32". The housing is made of galvanized steel to prevent corrosion. The rotor is supported by two pillow block bearings which can be maintained or replaced without the removal of the rotor from its casing or the media from its spoke system.

Optional Temperature Control Panel - Variable speed control shall be accomplished by the use of an A/C inverter. The inverter shall include all digital programming with a manual speed adjustment on the front of the inverter. The drive system shall allow for a turndown ratio of 80:1 (20 rpm to 1/4 rpm). The control system shall include four linearized thermistor sensors as follows:

- (1) Proportional temperature controller mounted in the supply air stream.
- (2) Differential summer/winter changeover sensors mounted in the outdoor and return air streams.
- (3) Frost prevention sensor located in the exhaust air stream.
- (4) Digital readout of the temperature readings recorded by these sensors and control set-points is displayed by the control panel.

Optional Digital Performance Display Module - Digital read out confirming the effectiveness of the energy wheel via temperature readings recorded by these sensors and control set-points shall be displayed by the control panel.

B. Warranty - The unit manufacturer shall warrant to the Buyer that for a period of eighteen months from the date of shipment the goods to be delivered to the Buyer shall in all material respects be free from defects in material and workmanship when used in a proper and normal manner. Should any failure to conform to the above appear within eighteen months after the date of shipment, the unit manufacturer shall upon prompt notification thereof during the Warranty Period and confirmation to the unit manufacturer's satisfaction that the goods have been stored, installed, operated and maintained properly and in accordance with standard industry practice, correct the non-conformity at the unit manufacturer's option either by repairing any defective part or parts or by making available at the unit manufacturer's plant a repaired or replacement part.

How to Reach SEMCO

You can reach SEMCO Incorporated by phone, fax, mail, or e-mail.

SEMCO Incorporated
DWP Service
1800 East Pointe Drive
Columbia, MO 65201-3508

888-4SEMCOINC (888-473-6264)
573-443-1481
Fax: 573-886-5408
e-mail: aqpinfo@semcoinc.com

For information about SEMCO Incorporated, our desiccant wheel products and services, please point your web browser to www.semcoinc.com. There, you will also find the latest news from SEMCO and examples of how SEMCO's energy recovery systems are being applied on a daily basis in a multitude of applications.

Wheel Configuration Checklist



Desiccant Wheel Products

JOB NAME _____

UNIT TAG _____ **DATE** _____

WHEEL ARRANGEMENTS

Arrangement A

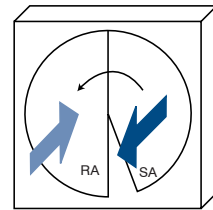

Arrangement B

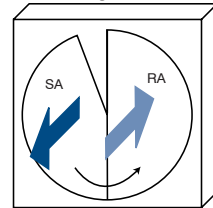

Arrangement C

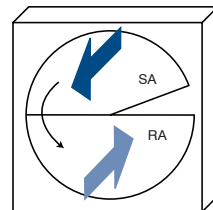

Arrangement D

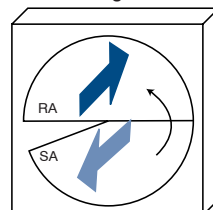

Arrangement E

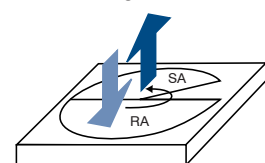

Arrangement F

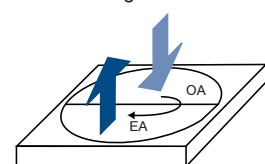

RA: Return Air
SA: Supply Air
OA: Outside Air
EA: Exhaust Air

TYPE OF UNIT

TE3: Total Energy Wheel
TS: Sensible Only Energy Wheel

UNIT MODEL NUMBER

3, 5, 9, 13, 18, 24, 28, 35, 43, 46, 56, 70

PURGE INDEX SETTING

0, 1, 2, 3, 4, 5, 6, 7

UNIT MOUNTING ARRANGEMENT

A, B, C, D, E, F

MOTOR TYPE

0: 208/230V/1Ph/60Hz, Variable Speed, With Inverter
1: 208/230V/3Ph/60Hz, Variable Speed, With Inverter
2: 460V/3Ph/60Hz, Variable Speed, With Inverter
3: 208-230V/3Ph/60Hz, Variable Speed, Without Inverter
4: 460V/3Ph/60Hz, Variable Speed, Without Inverter
6: 208-230V/1Ph/60Hz, Constant Speed
7: 208-230V/3Ph/60Hz, Constant Speed
8: 460V/3Ph/60Hz, Constant Speed
Note: Not all motors are available in all sizes

TEMPERATURE CONTROLLER RWX62

0: No controller
1: 24V/1Ph
2: 120V/1Ph

ROTATION DETECTOR

0: No rotation detector
1: 24V/1Ph
2: 120V/1Ph

Please check one:

Hold for Approval

Release for Production

Signature _____



Certified, Specified, Proven™

1800 East Pointe Drive
Columbia, Missouri 65201-3508
1-888-4SEMCOINC (1-888-473-6264)
573-443-1481
Fax: 573-886-5408
E-mail: aqpinfo@semcoinc.com

www.semcoinc.com