



# **The Odyssey**

## **Condominium**

**Arlington, Virginia**

**Aaron Snyder**  
**Structural**  
**Spring 2006**  
**Senior Thesis**  
**Professor Parfitt**

# The Odyssey

## Arlington, VA

Monument Realty



### Project Team

- **Owner:** Monument Realty LLC
- **Architect:** Shalom Baranes Associates
- **Construction Manager:** Donohoe Construction
- **Structural:** Ehlert/Bryan Inc.
- **Concrete:** SMC Concrete Construction Inc.
- **Curtainwall:** Emmitsburg Glass Co.

### Project Overview

- 16 story condominium & 2-3 story townhouses
- 3 story sub-level parking garage
- **Total Area:** 475,650 S.F.
- **Estimated Cost:** \$65 million
- **Projected Duration:** April 2004 – June 2006
- **Project Delivery Method:** Design – Bid – Build

### Architectural

- Penthouse outdoor rooftop swimming pool & terrace
- Rooftop concrete and steel beam trellis
- Platinum penthouse suites
- Partial full height curtain wall and brick façade
- Exposed concrete slab balconies
- Accompanying retail stores and townhouses



### Electrical

- **Primary:** 45 KVA 277/480V transformer
- **Secondary:** 45 KVA 120/208V transformer
- **Emergency:** 250 KW 277/480V generator
- Strip florescent lights in garage & upper corridors
- Wall & Surface mounted lights in lower corridors
- Recessed incandescent lights in apartment spaces

### Mechanical

- 14,000 cfm HVAC unit heats & cools public spaces
- Double cell rooftop cooling tower
- 2 sets of intake/exhaust fans & electric unit heaters for garage circulation
- Apartment air-air unit heat pumps: 600 - 1800 cfm
- Several AHU's for penthouse amenity spaces

### Structural

- **Foundation:** reinforced mat footings
- **Garage:** reinforced column & 8" 2-way concrete slab
- **Superstructure:** reinforced column & post-tensioned 8"- 11" 2-way concrete slab floor system
- **Lateral:** reinforced concrete shear walls
- **Roof:** typical floor slab with waterproofing & pavers



**Aaron Snyder**

**Structural**

**The Pennsylvania State University**



## Table of Contents

Executive Summary .....	1
Design Professionals .....	2
Building Background .....	3
Building Information.....	4
Structural Description .....	7
Proposal .....	11
Structural Redesign .....	13
Flat Plate Design .....	14
Column Design .....	22
Lateral System Design .....	26
Construction Study .....	33
Cost Comparison	
Schedule Comparison	
Building Envelope Study .....	39
Curtain Wall Assembly	
Brick Veneer/ Window Assembly	
Thermal Analysis	
Conclusion.....	43
Credits/Acknowledgments .....	44
Appendix	
A – Lateral Loads	
B – Reinforcement Design Table	
C – Column Load Take-Down Tables	
D – Deflections / Story Drift	

---

# **Executive Summary**





## Executive Summary

The Odyssey Condominium is a luxury mid-rise residential building located in Arlington, Virginia. The building features a 16 story tower with glass curtain walls and brick veneer containing condominium units on the upper levels. A two-way post-tension flat plate was designed throughout the tower structure in order to limit overall building height under code restrictions. The system provides a minimum structural thickness of the flat plate design over large spans and reduces floor-to-floor heights of the tower structure.

This report is an investigation of a redesign of the floor system for the residential levels of the Odyssey. A structural redesign of the flat plate system will provide a better understanding of the design implications of incorporating an alternative system into the residential design scheme of a two-way post-tensioned flat plate design. Design considerations include maintaining the integrity of residential spaces and limiting overall building height. The lateral system is also a consideration for the redesign with loads developed from ASCE 7-02. A cost analysis and schedule for construction of a typical floor will focus on the difference in the structural design of the proposed system for comparison with the post-tensioned design.

The proposed floor system is a conventionally reinforced two-way flat plate. The system met design criteria of maintaining the existing ceiling heights without exceeding building height limitations. The effective structural depth of the system increased as a result of designing with conventional reinforcement. Column sizes increased slightly with a modification of concrete strengths to maintain a uniform column size throughout the entire building. The proposed flat plate system increased overall building weight resulting in a design adjustment to the proposed shear wall system. The flat plate was incorporated into the lateral design with an addition of 6 levels to the central shear walls. Structural cost of the proposed system was higher per square foot with a majority of the cost difference from additional reinforcement in the flat plate. The average duration per floor for the proposed system was shortened without the added construction time of placing and jacking post-tensioned tendons. Although the proposed system met design criteria, the overall structural design and cost implications are more feasible with a two-way post-tensioned flat plate design in the residential levels of the Odyssey.



# **Design Professionals**





## The Odyssey Condominium

Aaron Snyder  
Structural Option

---

### Design Professionals

**Owner** Monument Realty, LLC  
1155 Connecticut Ave. NW, 7<sup>th</sup> Floor  
Washington, DC 20036  
*www.monumentrealty.com*  
Contact: Michael Blum, Senior Vice President

**Architect** Shalom Baranes Associates  
3299 K St., NW, Suite 400  
Washington, DC 20007  
*www.sbaranes.com/index.htm*  
Contact: Andrew Taylor

**Structural Engineer** Ehlert / Bryan Inc.  
1451 Dolley Madison Blvd., Suite 220  
McLean, VA 22101-3812  
*www.ehlert-bryan.com/home.html*  
Contact: Jason Sparrow

**Construction Manager** Donohoe Construction Co.  
2101 Wisconsin Ave, NW  
Washington, DC 20007  
*www.donohoeconstruction.com*  
Contact: Jon Peterson

**Mechanical Engineer** Mendoza, Ribas, Farinas & Associates  
6265 Executive Blvd.  
Rockville, MD 20852

**Curtain wall** Emmitsburg Glass Co.  
2 Creamery Way  
Emmitsburg, MD 21727  
*www.eglass.net*

**Concrete** SMC Concrete Construction, Inc.  
Annandale, VA

# **Building Background**







## The Odyssey Condominium

Aaron Snyder  
Structural Option

---

### Building Background

The Odyssey Condominium is a prominent feature of the Arlington sky line and stands out as a latest addition to Northern Virginia's growing number of luxury residential buildings. It is located outside the court district on 15<sup>th</sup> Street and Claredon Boulevard. The Odyssey's location also provides excellent views of Georgetown and the Washington Mall.



The 475,650 sq. ft complex features 2-3 story townhouses adjacent to 3 levels of underground parking on the lower levels. Rising above the lower levels are two residential towers perpendicularly askew of each other and featuring 16 stories of condominiums with 320 residential units including platinum suites located on the top floors. The towers have a gross floor area of 309,100 sq. ft and include condominiums that range from studio spaces to larger family dwellings. The platinum penthouse suites are custom designed to occupant requests with premium quality found throughout the kitchen, bathrooms, and living areas with adjoining balconies to enjoy the spectacular views.

The Odyssey's budget is approximately \$65 million including all scopes of work for project completion. The building is zoned under the Code of Virginia, Section 25 "Multiple-Family Dwelling Districts" which limits the building height to 180 ft. As an overlay of the General Land Use Plan (GLUP), the site is also designated as a "Special Affordable Housing Protection District" ("SAHPD"). The designation requires planned high density residential construction to replace existing affordable residential units located on the site. As a result of the SAHPD, a row of townhouses were incorporated into the design.

An executive decision was made early in the design to upgrade the Odyssey from apartments to luxury condominiums. The original building envelope called for a standard brick veneer with aluminum punch and strip windows. Aluminum curtain wall systems were recommended to enhance the architectural features of the envelope. The final design included three full-height curtain walls on the East elevation.

# **Building Information**





# The Odyssey Condominium

Aaron Snyder  
Structural Option

## Building Information

### Site / Location

The Odyssey Condominium is located at 2001 15<sup>th</sup> street outside downtown Arlington, Virginia.

Residential and office buildings of similar height surround the site to the North and West. The building sits on a triangular plot between 15<sup>th</sup> street and Claredon Blvd with the East edge of the site bordered by N. Scott St shown in the accompanying site plan.



### Architecture

The architectural program of the Odyssey is typical of a multi-use residential building with parking and commercial space on the lower levels and residential units throughout a tower structure. The condominium units and suites of a typical floor are depicted in a layout below. Larger two-bedroom suites are located primarily throughout the East (right) tower and extent of the West (left) tower. The units feature comfort amenities, full height windows with a ceiling height of 8'-8" and perimeter drop soffit at 7'-10" containing mechanical duct and sprinkler piping.

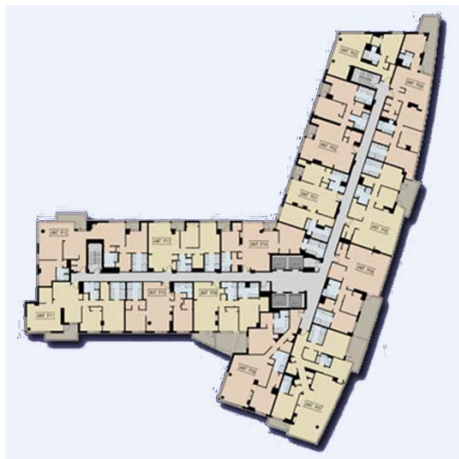

The retail and condominium main entry and lobby are made accessible by pedestrian or vehicle through a central courtyard with an accompanying garden. The penthouse level features an outdoor rooftop swimming pool and terrace, a pool lounge, and a state-of-the-art fitness center. A concrete column and steel-beam trellis framework following the curvature of the east elevation stands out on the rooftop as "a bold element" to the building design.



# The Odyssey Condominium

Aaron Snyder  
Structural Option

---

## Building Envelope

The Odyssey's main tower rise from the first floor above the parking garage levels, partially accompanying the retail stores on the north side. The east elevation displays full height aluminum curtain wall systems alternating with strip brick veneers incorporating sliding aluminum punch windows with partially surrounding metal panels. Extending from the condominiums on the East elevation are exposed concrete slab balconies with aluminum railings and mesh infill. The remaining elevations are primarily brick veneer and sliding windows with aluminum frames. The penthouse and mechanical loft are split with metal panel and brick veneers including both aluminum framed punch and strip windows.



## Electrical

The Odyssey's power is distributed through two main transformers in the basement vault. Main transformer #1 is a 120/208v 3phase-4w at 45kva. The transformer feeds a 600Amp 3phase-4w C/T Cabinet distributing to 5 Main disconnects switches ranging in 600A, 1000A, and 1200A. Main disconnect switches #1-#4 extend through the building to 2-3 1000A cable tap boxes distributed at adjacent floors for apartment loads. Main disconnect switch #5 is the house panel (MDP-L) with a 600Amp MCB 3phase-4w, 250v and feeds the penthouse mechanical room panel and main electrical room panel. Main service transformer #2 is standard 277/480v 3phase-4w at 45kva. The transformer feeds an 1800-Amp 3phase-4w C/T Cabinet in the adjacent switchgear room through a 24" cable tray. The cabinet feeds 3 main panels/disconnect switches: Main distribution panel with main switch (MDP-1H), Main service disconnect #2, and Emergency Service disconnect switch. Emergency power is provide by a 250KW generator at 277/480v 3phase-4w located in the first basement level adjacent to but separate from the switchgear and transformer vault. The generator feeds the fire pump and emergency service including the elevators with a 400Amp auto transfer switch.



# The Odyssey Condominium

Aaron Snyder  
Structural Option

---

## Lighting

The underground garage is predominantly lit with surface mounted strip florescent lights with T8 lamps. These fixtures are also found in the stairways, trash rooms, electrical closets, and upper level corridors. These lights run off of 277W while the remaining light fixtures found in the building run off of 120W. Lobby spaces have surface light fixtures set in linear groupings to ascent walls and lounge areas. Corridors on the lower levels are lit by wall mounted fixtures partially on emergency circuits to meet safety, fire, and egress requirements. The townhouses and Odyssey condominium units use recessed incandescent lights in the kitchen and closets, and wall mounted fixtures in the bathrooms. The living, bedroom, and dining spaces experience day lighting effects through the curtain-wall windows with track lighting in living spaces.



## Mechanical

The Odyssey's mechanical system is designed with several components to complete the entire heating and cooling of the complex. The underground garage has 2 intake and exhaust fans 25,000 - 42,000 CFM each, depending on level. Circulating fans move the air throughout the space with electric unit heaters to control the temperature. The units are heated and cooled with individual water to air heat pumps ranging from 600 - 1800 CFM. A 2-cell cooling tower and several additional AHUs are located on the roof to cool public spaces such as the penthouse exercise room. Also, a 14,000 CFM HVAC unit on the roof supplies 100% outside air for heating and cooling of public corridors throughout the building.



# **Structural Description**







---

## Structural Description

### Foundation

The primary foundation structures of the Odyssey are concrete footings of various rectangular sizes, depths, and reinforcement throughout the lower garage level footprint.

Individual column footings are typical; however 54" deep mat footings distribute larger gravity loads and resist overturning from integrated shear walls. The primary mat foundation spans over numerous columns which support shear walls beginning on the 1<sup>st</sup> floor of the building. A second mat footing resists the lateral overturning through core shear walls located around the central elevator shafts depicted in a partial foundation plan shown to the right.

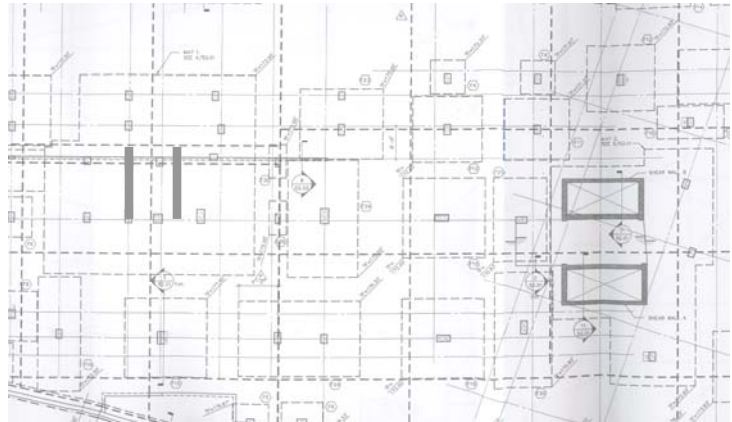

Continuous strip footings typically sized at 2'-0" x 1'-4" support a perimeter bearing wall surrounding the lower garage levels.

### Floor Systems

The lower garage level (B3) is composed of 4" concrete slab ( $f'c=5\text{ksi}$ ) on grade and reinforced with 6x6 – w1.4 x w1.4 wire mesh on 6mil vapor barrier over 6" compacted gravel.

The remaining lower garage levels through the first floor are primarily 8.5" conventionally reinforced 2-way concrete flat plate with drop panels. Drop panels are located at specified columns and typically extend 4-1/2" to 8" below the slab. Typical bays sizes for the reinforced two-way system are 25'x25' and 17'x25'. The columns throughout the lower garage levels are placed according to parking space arrangements and vehicle egress. The garage column placement dictates the location of columns throughout the upper levels and result in offset arrangements in the tower structure.

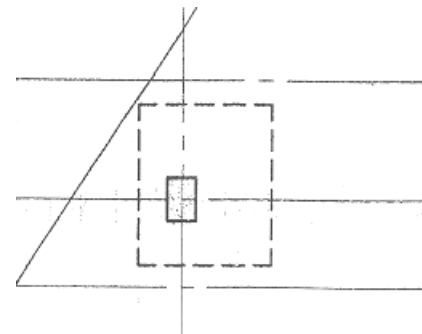



# The Odyssey Condominium

Aaron Snyder  
Structural Option

The Odyssey tower is primarily an 8" two-way post tensioned flat plate ( $f'_c=5\text{ksi}$ ) with continuous bottom reinforcement of #4 bars @ 24" o.c in each direction. Negative moment reinforcement of the slab at column junctions is typically #4 bars developed to  $.33l_n$  in both span directions. The post tensioning are 7 wire strand tendons spanning over typical frames in the short direction and draped at mid spans increasing the allowable stresses in the concrete. The post-tensioned flat plate construction yields higher span/depth ratios effectively reducing overall structural depth and material quantity. Floor bays vary in size and orientation however 25' x 22' and 25' x 28' are typical.

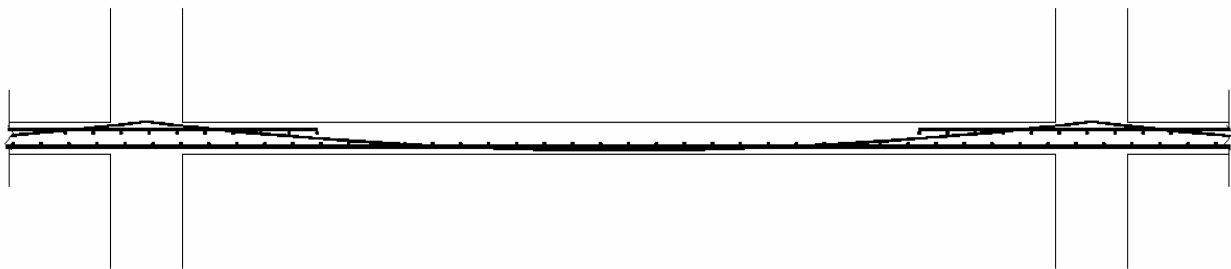

*Typical Flat plate Post-Tensioning and Reinforcement Layout*

## Columns

The columns of the Odyssey, levels 1-16, support the floor systems and are typically sized at 18" x 26" with #11 bar reinforcement. Round columns are found at the corners of the tower with primarily architectural design influences not to detract from symmetric corner strip windows with conventional rectangular columns. Concrete strengths vary to resist accumulated gravity loads and increase constructability by maintaining column uniformity.

Levels B3-B1 : 6000psi

Levels 1-4 : 8000psi

Levels 5 : 6000psi

Levels 6-16 : 5000psi



## Lateral System

The lateral resisting structural elements of the Odyssey are groupings of shear walls placed throughout the floor plan integrated with a slab frame system. The entire post tensioned flat plate system acts as series of moment frames transferring lateral forces through the plate into adjacent columns. Banded tendons span longer frame directions and are depicted in the floor plan creating primary slab frames acting in combination with shear walls to resist direct effects on the building. Open residential spaces in the building limited feasible locations for shear wall construction capable of resisting full lateral forces. The integrated dual system enables minimal space intrusions of shear walls by placement around slab openings and egress towers. The contribution of the post-tensioned slab frame effectively distributed lateral forces with the central shear walls to the 4<sup>th</sup> floor. The locations of the shear walls are depicted below in plan with a description of each wall included on the following page.

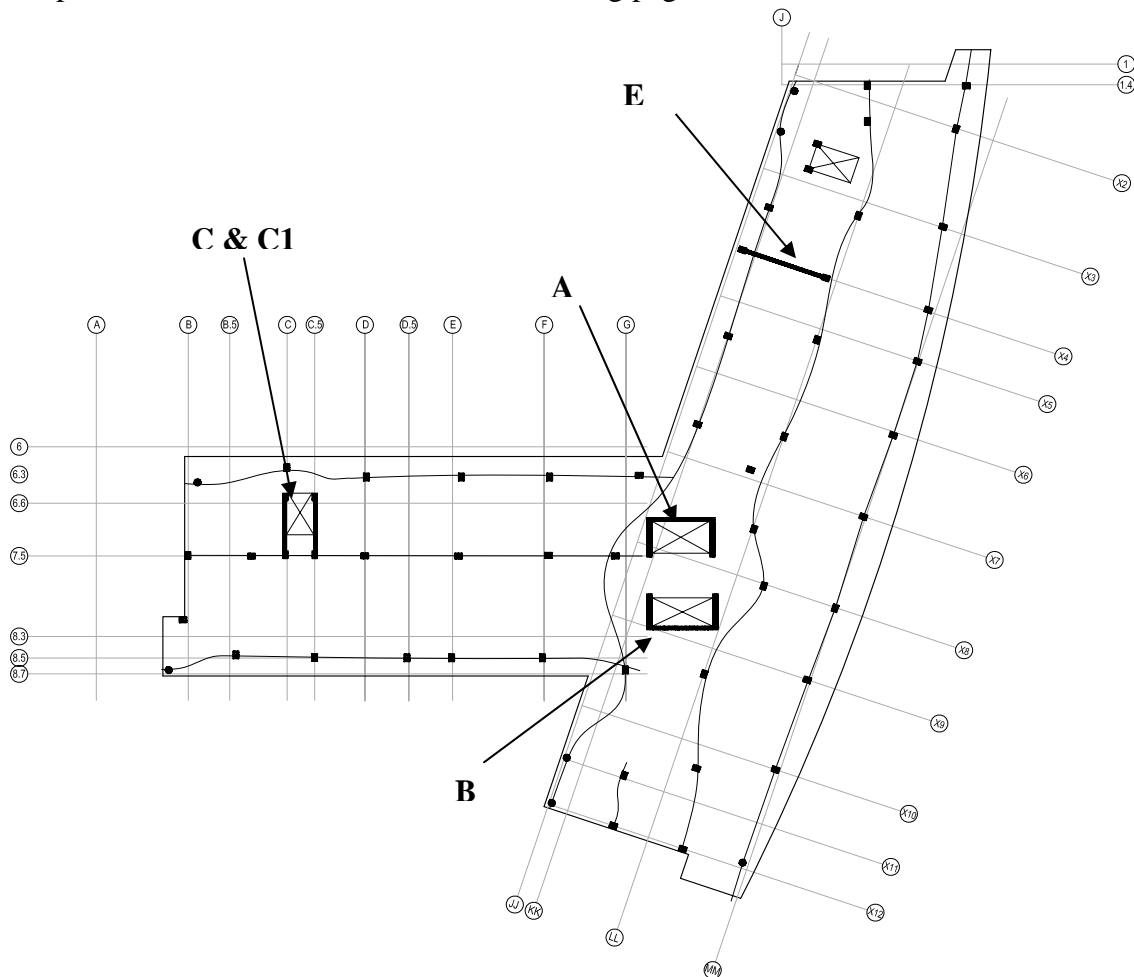

Fig. – Typical Floor Plan / Banded PT Layout



# The Odyssey Condominium

Aaron Snyder  
Structural Option

## Shear wall A:

Location: Surrounds 2 central-north elevator shafts

Range: B3 - 4<sup>th</sup> level

Size: North-South walls - 14' x 10'

East-West wall - 10'x17'-10"



## Shear wall B:

Location: Surrounds 2 central-south elevator shafts

Range: B3 - 4<sup>th</sup> level

Size: North-South walls - 14' x 10'

East-West wall - 10'x17'-0"



## Shear wall C , C1:

Location: Adjacent sides of the West stair tower.

Range: 1st - 16<sup>th</sup> level

Size: 10'x 13'-10.5"

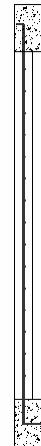

## Shear wall E:

Location: Column line X4 - North side of East tower

Range: 1st - 14<sup>th</sup> level

Size: 10'x 29'-5"

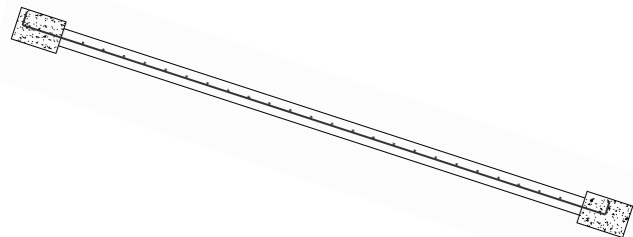

# Proposal





## Proposal

### Problem Statement

The Odyssey was designed with consideration of a height restriction by the Code of Virginia zoning ordinances. A minimum floor-to-floor height was required to construct the 16 level residential tower under the height restriction to maximize tenant occupancy. A two-way post-tensioned flat plate floor was designed for these restraints with a design depth of 8". Is there a feasible alternative floor system without post-tensioning? This study will investigate the design implications of an alternative system in a residential scheme. The construction cost and schedule of the systems will also be considered in the study.

### Proposed Solution:

The proposed alternative system will be designed as a two-way reinforced flat plate. The similar flat plate design will also allow the existing mechanical soffit designs to remain in residential units so there are limited alterations in MEP systems. The overall architectural design of the Odyssey will, for the most part, remain similar to details found under the existing system. The same number of levels and identical residential unit layouts will result in similar column locations and bay sizes throughout the floor plan. Columns will be designed to effectively maintain the architectural dimensions of the residential units with the concrete strengths adjusted for column uniformity. The lateral system will be analyzed with reinforced concrete shear walls extended through the building at their current locations. The alterations in the floor design will need to be taken into consideration when analyzing lateral effects.







## The Odyssey Condominium

Aaron Snyder  
Structural Option

---

### Solution Method:

The design of a 2-way reinforced flat plate will result in an acceptable slab depth to resist gravity loads and limit floor-to-floor height enough to comply with zoning ordinances. The concrete floor system will be designed in accordance with ACI 318-05 *Building Code Requirements for Reinforced Concrete*. The minimum slab thickness will be based on design provisions of ACI 318-05 Table 9(c) for flat plate construction. Deflection will be checked for adequacy in accordance with limitations set by ACI 318-05 Table 9(b). The reinforcement will be designed in accordance with provision of ACI 318-05 Chapter 13. Dead loads will be calculated for the self-weight of the slab with superimposed dead loads and live loads from IBC 2003 Table 1606. The resolved dead loads and live loads will be patterned over the frame and analyzed for the resulting controlling design moments distributed to the column and middle strips according to ACI 318-05 Section 13.6. Live load patterns to be investigated and slab deflection will be checked for adequacy in accordance with limitations set by ACI 318-05 Table 9(b). The flat plate will be designed and reinforced to accommodate the design moments resolved from a frame analysis. Column design will accommodate gravity loads in accordance with ACI 318-05.

The shear walls will be analyzed by a 3-D model of the lateral system in the ETABs analysis computer program. Wind and seismic loads will be computed for the building through provisions of ASCE 7-02 sections 6 & 9. The building deflection will be limited to  $H/600$  for crack control of the brick veneer making up the majority of the building envelope. Inter-story drift will be checked against the maximum limit of  $.020h_{sx}$  by provisions of ASCE 7-02.

# **Structural Redesign**



- **Flat Plate Design**
- **Column Design**
- **Lateral System Design**



---

## Structural Redesign

### Design Criteria

I redesigned floor system with a conventionally reinforced flat plate design without significant alterations to existing architecture and building systems. The flat plate was the typical floor system used throughout the residential towers of the Odyssey. The tower structure and corresponding levels will therefore be the focus of the redesign encompassing the gravity and lateral systems.

Design objectives of the redesign include maintaining existing ceiling heights within residential units without exceeding the maximum building height limitation. The proposed redesign will be investigated through alterations of the flat plate system and corresponding adjustments in the column and lateral system. The design loads for proposed structural redesign will be in accordance with provisions of ASCE 7-02.

The design of the flat plate was a cyclical process and was preliminarily designed for gravity loading then redesigned into the lateral system. The flat plate was integrated into the lateral design as a slab frame system with the shear walls. A diagram of the process is shown below with alterations to each system described in their respective design sections throughout the report.

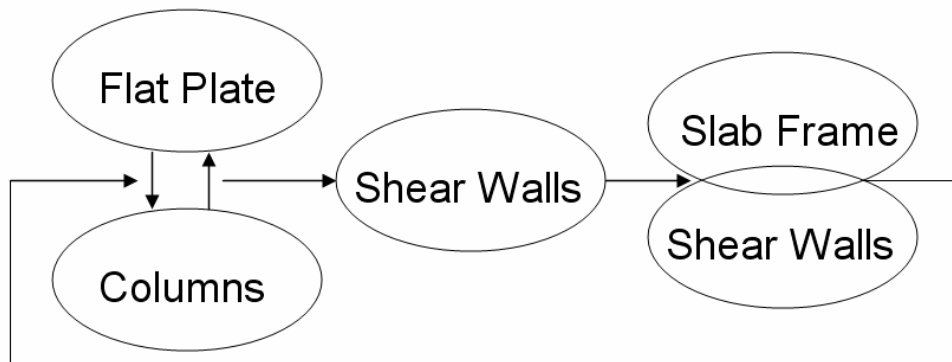



## Flat Plate Design

### Deflection

The minimum plate thickness was calculated based on developed methods for slab deflection control under service loads of the ACI 318-05 Building Code Requirements for Structural Concrete. Exterior and interior flat plate panels with reinforcement strength of 60,000psi are limited to a minimum thickness equal to  $\ell_n/30$  and  $\ell_n/33$ . I determined the maximum design span length between adjacent offset columns to be 28'-6". The minimum slab thicknesses were calculated for as 11" for exterior panels and 10" for interior panels.

I carried out a design check to ensure a minimum thickness of 11" for 5000 psi exterior panels. A control panel with a size of 28'-6" x 24'-6" was analyzed for maximum column and middle strip deformations resolved in either span direction. The overall deflection was limited to  $\ell/480$  for long-term deflection due to all dead loads and short term deflection due to live loads. The design check concluded that the minimum slab thickness for exterior panels would remain 11". The figure below depicts two-way flat plate deflection from superimposed strip deflections.

$$\Delta_{\max} = \Delta_{\text{col } x,y} + \Delta_{\text{mid } y,x}$$

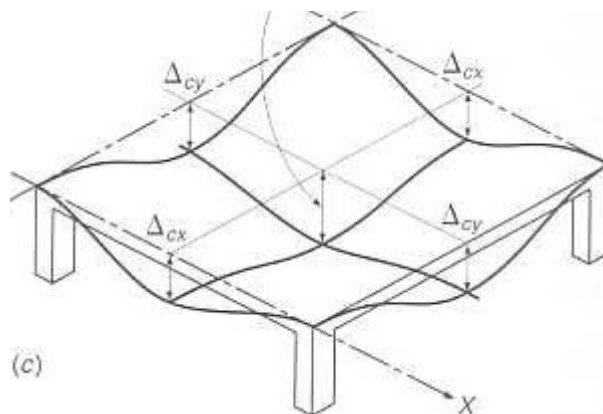

Flat Plate Deflection – (Reference: *Design of Concrete Structures, Nilson*)



### Punching Shear

Shear design considerations were also likely to control the slab thickness for the flat plate system. I investigated the minimum design thickness of 11” under both beam shear and punching shear failure to determine which condition would control the design. Several columns sized for the 11” slab weight by axial loads from a load take-down were considered for the shear design limitations. These columns included interior, exterior, and corner locations on the floor plan. Punching shear was found to control over beam shear for loading on the tributary area at each column location. Deflection and punching shear ultimately limit the minimum design slab thickness to 11” after considering the concrete nominal shear strength capacities in accordance to ACI 318-05 (11.12). The minimum design thickness was sufficient for punching shear failure and would not need additional shear reinforcement at column interfaces. However, additional shear reinforcement may be required to resist the unbalanced moment transfer through shear and will be addressed in the frame analysis and reinforcement design sections.

### Gravity Design

The Equivalent Frame method was chosen for the design of the proposed 11” flat plate system. The Direct Design Method was not used based on design limitations resulting from offset column locations and uneven span orientations in each frame direction. Load path configurations were created for the frames throughout the floor plan in both grid directions. Support lines spanning between bays indicate the assumed load path from the slab into reinforcement placed at the columns. The figures below depict the assumed support lines of the flat plate system.

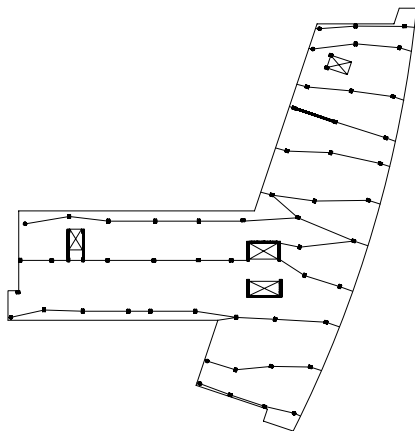

Horizontal Support Line Configuration

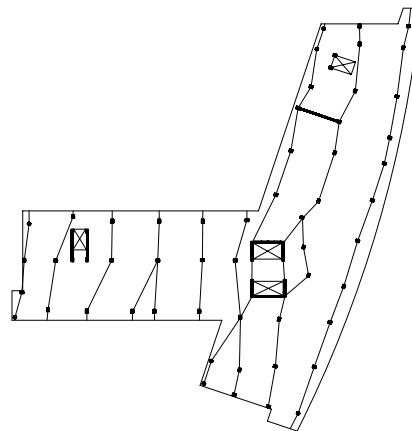

Vertical Support Line Configuration



# The Odyssey Condominium

Aaron Snyder  
Structural Option

Design strips for each support line were created by expanding a tributary width about the midpoint of each span. The design strips will be used in the frame analysis to determine design moments by the transfer of factored loads through each frame. The typical floor plan contains both straight and offset column arrangements creating numerous design strips for the flat plate system. The straight frame arrangements have relatively rectilinear design strips which suite input protocol for most computer analysis programs. As a result, the offset strips designed in PCA ADOSS were reconfigured and idealized to specified widths for a straight frame arrangement. The following figures depict an overview of the idealization process for offset design strips.

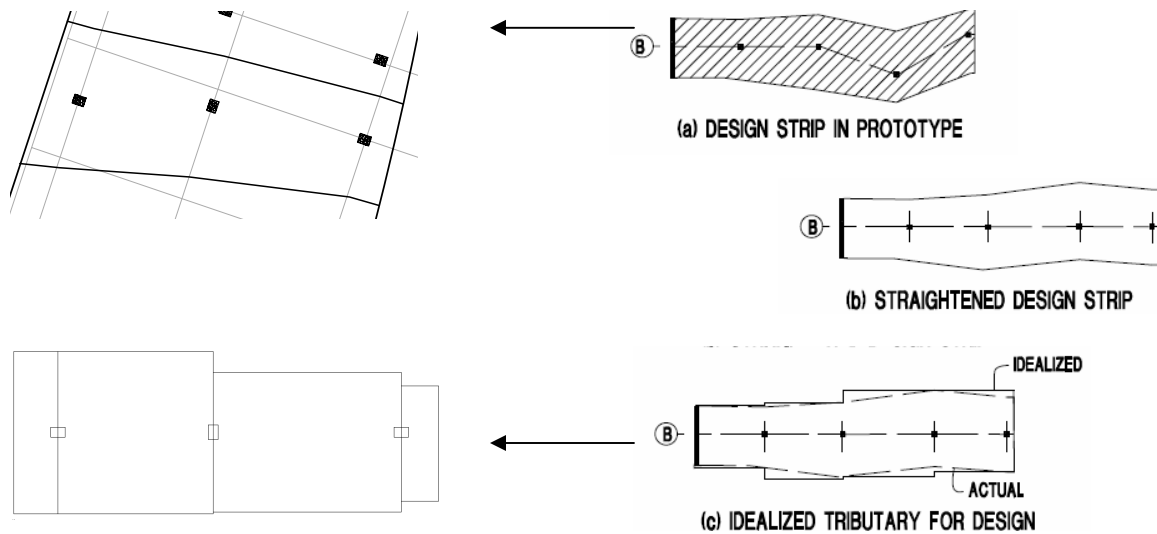

I first analyzed a rectilinear frame with the ADOSS program for design moments of  $1.2D + 1.6L$  load combination. This frame is relatively straight when compared to the offset columns located in the skewed tower section and is an easier design check for the proposed computer analysis. A concrete strength of 5000 psi was analyzed with imposed residential level dead load and live load patterns.

<b>Dead :</b> _____		<b>Live:</b> _____	
Roof	50 psf	Roof	30 psf
Mechanical	150 psf	Mechanical	150 psf
Residential	27 psf	Residential	40 psf
Façade	32 psf	Public Space	100 psf





## The Odyssey Condominium

Aaron Snyder  
Structural Option

---

I checked the computer design moments for the strip using the Equivalent Frame method with torsion members developing an equivalent stiffness for moment distribution to supporting columns. I distributed moments over the frame using the calculated member stiffness. Multiple live load patterns were also analyzed for the distribution to determine maximum negative and positive design moments. The results of the hand check were conservative compared to the computer analysis. I believe the difference was a result of the span to column width ratios assumed for rotated columns when calculating member stiffness. I felt the computer analysis results were accurate and properly accounted for the column orientations in the frame. I concluded that ADOSS was an appropriate means of developing the design moments in the remaining frames of the flat plate for the reinforcement design.

### **Reinforcement**

The design criterion of the positive and negative reinforcement in the flat plate was based on material efficiency. Several bar sizes were investigated for overall material quantity required to resist the distributed design moments, specifically #4, #5, #6, #7 bars. I decided that alternating positive and negative reinforcement bar sizes would limit errors during placement, increase efficiency per required spacing, and decrease excessive bar clustering. The two series of reinforcement I decided to analyze were #4 / #6 bars and #5 / #7 bars.

Column and middle strip distribution percentages were calculated in accordance with ACI 318-05 (13.6) and checked against ADOSS strip distribution percentages. Reinforcement was designed for minimum shrinkage and temperature limitations and to resist the distribution of design moments within the designated strips. A portion of the negative reinforcement was designed within effective column width to resist the flexural transfer of unbalanced moment at supports. Offset strips were designed with column strip reinforcement spaced over the entire panel to ensure adequate load path distribution into the supports. Additional shear stresses caused by the unbalanced moments at supports were under the allowable limit. The design thickness was sufficient for punching shear failure and would not require additional reinforcement.



# The Odyssey Condominium

Aaron Snyder  
Structural Option

Both sets of reinforcement were designed in each frame to compare the quantity of bars used in the design. The larger reinforcement set required fewer bars to resist the design moments, however it was necessary to consider the tonnage of each design for comparison of material quantity. The approximate reinforcement weights were calculated using minimum development lengths for two-way flat plates in accordance with ACI 318-05 (13.3.8).



The overall weight of steel for #5 / #7 bars was 46.3 tons, compared to only 41.1 tons for #4 / #6 bars. Potential cost savings in material alone suggest that the smaller bar pattern with tighter spacing a more viable option. The lighter reinforcement is also preferable for distribution and placement in the field over heavier reinforcement. The design of the flat plate will use #4 bars for positive reinforcement throughout spans and #6 bars for negative reinforcement at the columns as depicted in the floor plan below.

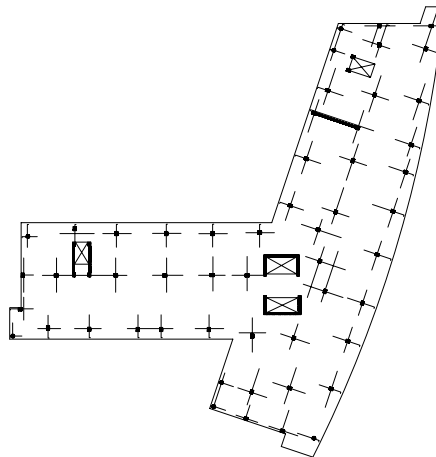

Negative Reinforcement Configuration



---

## Lateral Design

The proposed design of the lateral system was originally for shear walls to contribute 100% of the lateral force resistance. The design was altered to incorporate the flat plate system in combination with the shear walls in a slab frame action. Details of the design alteration are covered in the Lateral System Design section. As a result of the alteration, the flat plate must be considered as a lateral resisting element and designed to resist lateral load effects.

The flat plate was redesigned with the main lateral contribution from the larger frame sections. The frames resist direct loading and torsion effects in combination with shear walls oriented in the same principle directions. An assumed distribution of 10% of the total lateral story force was applied to each frame aiding the shear walls in resisting lateral loads. The frames and accompanying shear walls are depicted in the floor plan below.

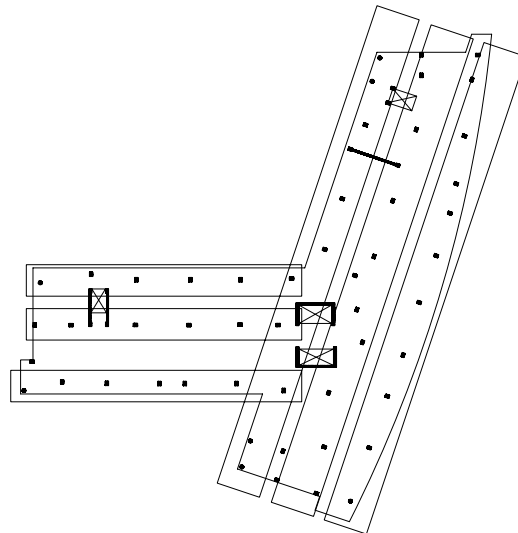

Slab Frames / Shear walls

The frames were analyzed in ADOSS under the lateral load combination  $1.2D+1.0L+1.0E$ . Lateral forces were applied to the frame as were live load patterns. Design moments increased as well as the unbalanced moments caused by lateral force dissipation in the frame by shear transfer at the columns. The induced stress from additional shear transfer of the unbalanced moments did not exceed the allowable stress of the flat plate.



# The Odyssey Condominium

Aaron Snyder  
Structural Option

## Reinforcement

Column and middle strip reinforcement was designed with the same moment distribution procedure used for the gravity load analysis. The minimum development lengths for the flat plate design were adjusted for lateral loading. A minimum of one quarter of the negative reinforcement is required to extend the full length of the span. The adjustment increased the overall weight of #4 / #6 bars to 42.4 tons. I developed a series design tables to develop column and middle strip reinforcement and to calculate the total weight of steel for the design. An example of a design table for a lateral resisting frame is shown below with designated reinforcement for column and middle strips and total calculated steel weights.

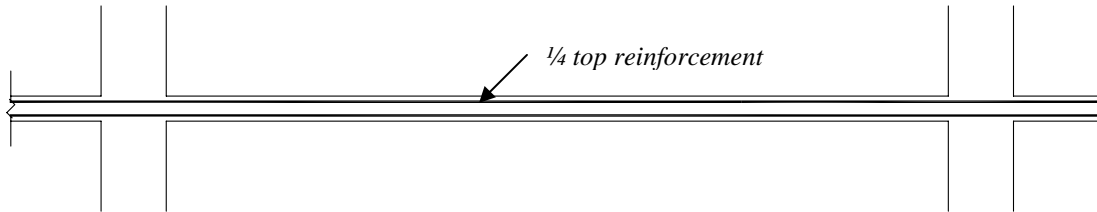

Lateral Minimum Development Lengths

Frame 6.3

Location		Strip	% (Gamma)	Design Moment (ft-k)	Total width (ft)	Moment/foot of width (ft-k/ft)	Rebar Design		Quantity		Length (ft)	Weight (plf)	Total Wt. (lbs.)
MAX / U Moment (ft-k)							#Size (#)	S (in)	Total (# of bars)	C.S./M.S. (# of bars)			
Support	1	Column Strip	0.98	118.9	13.1	9.1	6	18	9	13	8	1.502	175.2
167.3		Unbalanced $M_r$	0.60	100.4	3.3	30.4	6	6	7		28	1.502	138.1
121.3		Middle Strip	0.02	2.4	7.1	0.3	6	18	5	5			
Span	2	Column Strip	0.60	144.8	13.1	11.1	4	8	20	20	28	0.668	633.1
241.4		Middle Strip	0.40	96.6	7.1	13.6	4	6	14	14			
Support	2	Column Strip	0.75	235.1	13.1	17.9	6	12	13	17	18	1.502	468.6
173.7		Unbalanced $M_r$	0.62	107.7	3.7	29.1	6	6	7		24	1.502	151.4
313.5		Middle Strip	0.25	78.4	7.1	11.0	6	18	5	5			
Span	3	Column Strip	0.60	44.8	13.1	3.4	4	12	13	13	24	0.668	323.8
74.6		Middle Strip	0.40	29.8	7.1	4.2	4	12	7	7			
Support	3	Column Strip	0.75	182.0	13.1	13.9	6	12	13	15	15	1.502	359.3
158.9		Unbalanced $M_r$	0.62	98.5	3.7	26.6	6	8	6		26	1.502	146.0
242.6		Middle Strip	0.25	60.7	7.1	8.5	6	18	5	5			
Span	4	Column Strip	0.60	108.2	13.1	8.3	4	12	13	13	26	0.668	412.5
180.4		Middle Strip	0.40	72.2	7.1	10.2	4	8	11	11			
Support	4	Column Strip	0.75	229.7	13.1	17.5	6	12	13	14	15	1.502	340.5
127.1		Unbalanced $M_r$	0.62	78.8	3.7	21.3	6	10	4		26	1.502	135.1
306.2		Middle Strip	0.25	76.6	7.1	10.8	6	18	5	5			
Span	5	Column Strip	0.60	91.3	13.1	7.0	4	12	13	13	26	0.668	375.5
152.2		Middle Strip	0.40	60.9	7.1	8.6	4	10	9	9			
Support	5	Column Strip	0.75	242.3	13.1	18.5	6	10	16	17	15	1.502	391.0
133.9		Unbalanced $M_r$	0.62	83.0	3.7	22.4	6	8	6		26	1.502	164.3
323		Middle Strip	0.25	80.8	7.1	11.4	6	18	5	5			
Span	6	Column Strip	0.60	118.1	13.1	9.0	4	10	16	16	26	0.668	458.0
196.9		Middle Strip	0.40	78.8	7.1	11.1	4	8	11	11			
Support	6	Column Strip	0.75	80.3	13.1	6.1	6	18	9	13	16	1.502	348.1
167.7		Unbalanced $M_r$	0.60	100.6	3.2	31.4	6	6	6		26	1.502	126.9
107		Middle Strip	0.25	26.8	7.1	3.8	6	18	5	5			

$A_{min} = .0018bd$   
24 in<sup>2</sup>/ft

$A_{max} = .008bd$   
1.056 in<sup>2</sup>/ft

#6 1.5 tons  
#4 1.1 tons



## The Odyssey Condominium

Aaron Snyder  
Structural Option

---

### Summary

The proposed flat plate system was designed with a structural thickness of 11” to meet a  $\ell/480$  deflection limitation and to resist punching shear failure. I designed the reinforcement for the system as a combination of #4 / #6 bars with a total design weight of 42.4 tons. A smaller combination of reinforcement was selected to decrease associated material and labor costs based on the overall weight of the reinforcement design.

The flat plate also allowed the existing architectural program to remain throughout the entire building. Column locations were undisturbed throughout the floor plan ensuring the layout of residential units remained consistent. The adjusted structural depth of the flat plate increased the overall building height to 179’ from the average site elevation, meeting requirements of the zoning height limitation of 180’.

The adjusted thickness of the flat plate design added a significant amount of dead load to the structure. As a result, the columns and lateral system of the structure must be designed with consideration of the imposed loads. The following section further develops the column design for the flat plate system.



## Column Design

### Design Criteria

The design objectives for the supporting columns were similar to the design of the flat plate system. Minimum column dimensions would need to be considered to ensure the architectural integrity of the residential spaces. The design of a uniform column size would promote a faster schedule by construction of repeatable floors. The columns were subjected to the gravity loads listed below.

<u>Dead :</u>		<u>Live:</u>	
Roof	50 psf	Roof	30 psf
Mechanical	150 psf	Mechanical	150 psf
Residential	27 psf	Residential	40 psf
Façade	32 psf	Public Space	100 psf

### Column Design

I started the by selecting a series of columns that provide a good representation of critical loading at different locations in the floor plan. The columns had large tributary areas positioned at interior, exterior, and corner locations. The same columns were analyzed for punching shear failure in the frame analysis. The partial floor plan below depicts the selected columns and their respective tributary areas.

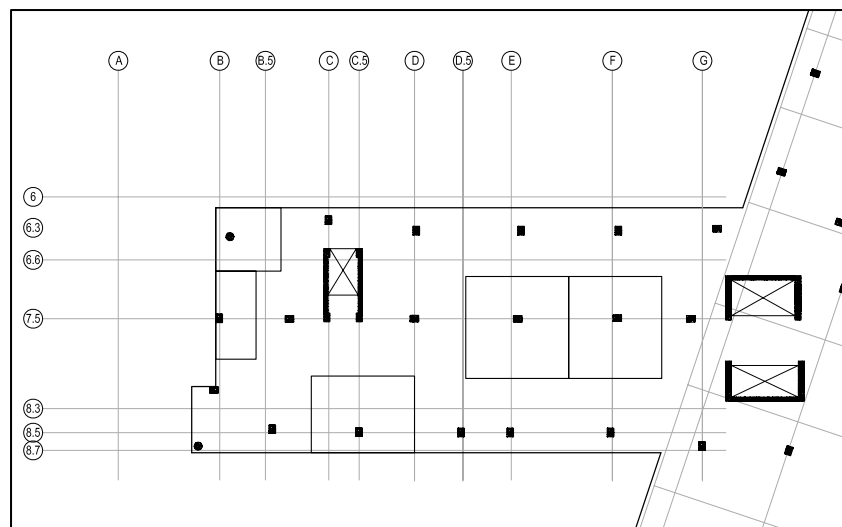

*Critical Columns & Tributary Areas*





# The Odyssey Condominium

Aaron Snyder  
Structural Option

## Axial Load

Axial loads were developed on each column by performing a load take-down for levels 2 –16 of the tower structure. Each level was designated dead and live loads depending on the use of the space within each designated tributary area. The loading from the 2<sup>nd</sup> - 15<sup>th</sup> level is entirely residential and public space and the 16<sup>th</sup> level is mechanical. The interior columns were located along corridors with a portion of the tributary area residing in designated public space loading. I decided to design the columns conservatively by assuming the public space live load of 100psf for the residential levels.

I created a column load take-down design table to accumulate the distributed dead and live loads throughout the levels. The total tributary self weight of the flat plate and columns located above a particular level were added into the accumulated dead load calculation. Live load reduction was also considered for the accumulated tributary areas with reduction factors applied to each column based on the specified location. The accumulated factored axial forces are listed in the design table below for an interior column located at column line E / 7.5.

			Column E/7.5 Interior				$K_{LL} =$	4	
Level/Column:	Live (PSF)	Dead (PSF)	Area (ft <sup>2</sup> )	$A_T$ (ft <sup>2</sup> )	Reduction	Live Load (kip)	Reducd LL (kip)	Dead Load (kip)	Factored Load (kip)
Roof	30	50	700	700	1.000	21.0	21.0	139.9	201.5
16	150	150	700	1400	0.450	126.0	56.8	347.5	507.8
15	100	27	700	2100	0.414	196.0	81.1	468.6	692.0
14	100	27	700	2800	0.400	266.0	106.4	588.9	877.0
13	100	27	700	3500	0.400	336.0	134.4	709.3	1066.2
12	100	27	700	4200	0.400	406.0	162.4	829.6	1255.4
11	100	27	700	4900	0.400	476.0	190.4	950.0	1444.6
10	100	27	700	5600	0.400	546.0	218.4	1070.3	1633.8
9	100	27	700	6300	0.400	616.0	246.4	1190.6	1823.0
8	100	27	700	7000	0.400	686.0	274.4	1311.0	2012.2
7	100	27	700	7700	0.400	756.0	302.4	1431.3	2201.4
6	100	27	700	8400	0.400	826.0	330.4	1551.7	2390.6
5	100	27	700	9100	0.400	896.0	358.4	1672.0	2579.8
4	100	27	700	9800	0.400	966.0	386.4	1792.3	2769.1
3	100	27	700	10500	0.400	1036.0	414.4	1912.7	2958.3
2	100	27	700	11200	0.400	1106.0	442.4	2033.0	3147.5

Column load take-down table – Interior column



### Biaxial Bending

The columns were designed under biaxial loading conditions from the unbalanced moments found in the ADOSS frame analyses. The maximum unbalanced moments were used to determine the required column reinforcement. I used PCA Column to design sizes and reinforcement with the specified factored axial loads and bending moments obtained from the previous analyses. The effects of slenderness were neglected for the design in accordance with ACI 318-05 (10.13.2). I used a range of concrete strengths to establish the minimum column size that will be constructed uniformly over the entire flat plate. A 20" x 26" column was found as a sufficient minimum uniform design size with 14 #11 bars. The column sizes on the 1<sup>st</sup> and 2<sup>nd</sup> levels were increased to 22" x 28" to accommodate the accumulated axial forces. Concrete strengths of the columns are listed below by level along with the typical reinforcement layout and accompanying interaction diagram.

<u>Level</u>	<u>Concrete Strength</u>
1-5	8000 psi
6-7	6000 psi
8-16	5000 psi

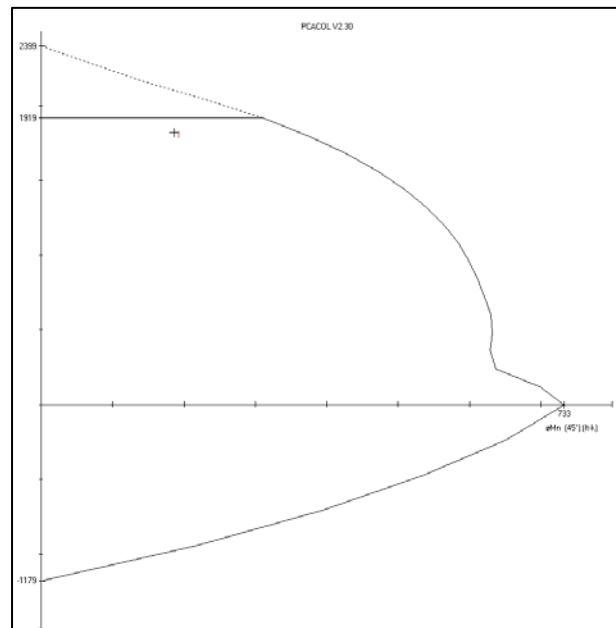
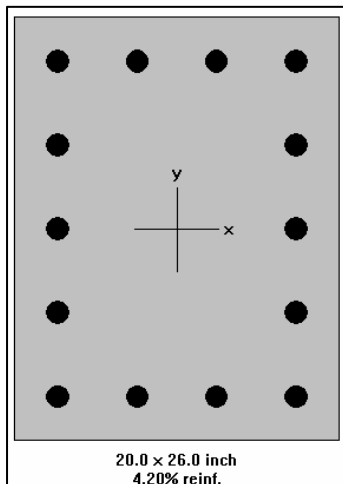



# The Odyssey Condominium

Aaron Snyder  
Structural Option

---

## Summary

The columns supporting the flat plate system were designed with the intention of limiting overall design size to ensure minimal architectural impacts on residential spaces. A uniform column size was desired throughout the floor plan in order to promote a faster building schedule by repeatable floor construction. The location of the columns would remain unchanged without the interruption of open spaces.

The columns were designed with a uniform size of 20”x 26”. The column design will not significantly affect residential spaces as most of the columns are integrated into protruding corners and wall spaces within the units. Material for column construction adjusted as a result of the redesign including concrete, alterations in strength, and reinforcing steel. The increase in the column design, as well as the flat plate thickness, add significant dead load to the structure resulting in alterations to the imposed lateral loads. The next section investigates the lateral implications of the gravity system redesign and will develop an analysis of the lateral system.



---

## Lateral System Design

### Design Criteria

The lateral system redesign will consider full lateral resistance by shear wall structures alleviating lateral resistance by the flat plate system. I originally assumed a long span design without post-tensioning would limit the lateral capability of the slab frame. The flat plate would act as a cracked section limiting structural stiffness opposed to the post-tensioned system designated Class U with un-cracked gross section properties.

The proposed design would adhere to the architectural program throughout a typical floor plan. Shear wall locations would remain at the central elevator shafts, the West stair tower, and an interior wall within a residential unit located in the skewed tower. The central shear walls will be extended from the existing design at the 4<sup>th</sup> level through the tower structure to resist the lateral loads from the increase in building height and weight. The locations of the shear walls are depicted below.

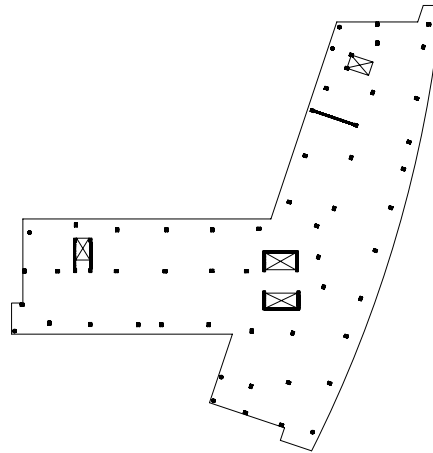

*Typical Floor Plan*

The lateral forces applied to the building by wind and seismic loading conditions will be calculated in accordance with provisions of the ASCE 7-02 design code. A maximum displacement of  $H/600$  was set as the design limit to control cracking in the brick veneer. The story drift was checked against the maximum limit  $.02h_{sx}$  for Seismic Use Group I in accordance with ASCE7-02 (9.5.2.8). The concrete strength of the shear walls will be 4000 psi throughout the entire structure with the specified existing dimensions.



# The Odyssey Condominium

Aaron Snyder  
Structural Option

## Seismic Loads

Seismic loads were calculated to account for the increased building height and weight as a result of the gravity system designs. The equivalent lateral force procedure was used to calculate the seismic forces on the building. Dead load for each level was calculated to include the added structural self-weight and super-imposed dead loads over the net floor area of each level. The resulting seismic story forces were calculated under the following design parameters in accordance with provisions of ASCE 7-02 Section 9. Full design calculations are found in Appendix A.

### Design Parameters

Location:	Arlington, Virginia	
Number of Stories:	N = 16	
Inner Story Height:	hs = varies - 9'-7" typ.	
Building Height:	hn = 171	
Seismic Use Group:	1	Table: 9.1.3
Occupancy Importance:	I = 1.0	Table: 9.1.4
Site Classification:	C	9.4.1.2
Accelerations:		
0.2 s	Ss = 0.179	Figure: 9.4.1.1(a)
1.0 s	S1 = 0.063	Figure: 9.4.1.1(b)
Site Class Factor:	Fa = 1.2	Table: 9.4.1.2(a)
	Fv = 1.7	Table: 9.4.1.2(b)
Adjusted Accelerations:	Sms = 0.2148	9.4.1.2.4-1
(max.)	Sm1 = 0.1071	9.4.1.2.4-2
Design Spectral Response	S <sub>DS</sub> = 0.143	9.4.1.2.5-1
Accelerations:	S <sub>D1</sub> = 0.0714	9.4.1.2.5-2
Seismic Design Category:	B	9.4.2.1(a/b)
Response Modification:	R = 5	Table: 9.5.2.2
Deflection Modification:	Cd = 4.5	

### Vertical Distribution of Seismic Forces

N-S Level, x	Load	Shear	Moment
	Fx (kips)	Vx (kips)	Mx (ft-kips)
Roof	64	0	10,736
16	109	64	16,502
15	121	174	16,867
14	104	295	13,391
13	100	399	11,888
12	90	499	9,870
11	81	589	8,057
10	71	670	6,444
9	62	741	5,025
8	53	803	3,798
7	45	857	2,757
6	36	902	1,894
5	28	938	1,206
4	21	967	683
3	14	988	317
2	7	1001	97
1	-	1008	-
		Σ =	109534

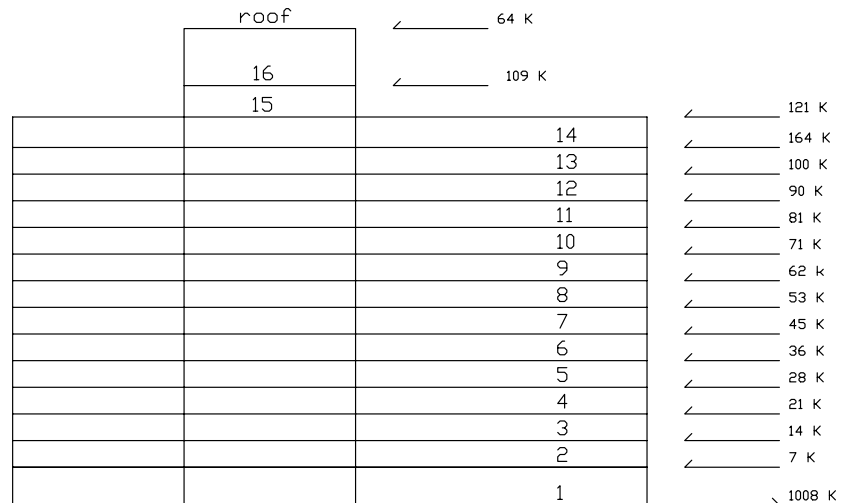

Seismic Force Distribution



# The Odyssey Condominium

Aaron Snyder  
Structural Option

## Wind Loads

Wind loads were calculated to account for the increase in building height. Design wind pressures were calculated by the Analytical Procedure in accordance with provisions of ASCE 7-02 Section 6. Design parameters and resultant wind forces are found in the Appendix A.

Wind Loading ( N-S )

Level	Story Height (ft.)	Elevation (ft.)	Tributary Height (ft.)	Tributary Width (ft.)	Tributary Area (ft <sup>2</sup> )	Wind Load (psf)	Wind Load (k)	Shear (k)	Moment (ft - k)
Roof	4	166.74	12.00	183	2196	17.6	39	39	-
16	16	150.74	13.63	183	2493	17.3	43	82	617.3
15	11.25	139.49	11.08	183	2028	17.1	35	117	1537.8
14	10.91	128.58	10.25	224	2295	16.9	39	155	2809.6
13	9.58	119.00	9.58	224	2147	16.7	36	191	4297.8
12	9.58	109.41	9.58	224	2147	16.4	35	226	6129.0
11	9.58	99.83	9.58	224	2147	16.2	35	261	8297.7
10	9.58	90.25	9.58	224	2147	15.9	34	295	10799.8
9	9.58	80.66	9.58	224	2147	15.6	34	329	13629.1
8	9.58	71.08	9.58	224	2147	15.3	33	362	16779.9
7	9.58	61.50	9.58	224	2147	14.9	32	394	20245.1
6	9.58	51.91	9.58	224	2147	14.6	31	425	24017.5
5	9.58	42.33	9.58	224	2147	14.1	30	455	28089.3
4	9.58	32.75	9.58	224	2147	13.6	29	484	32451.9
3	9.58	23.16	9.58	224	2147	12.9	28	512	37094.2
2	9.58	13.58	11.58	224	2594	12.2	32	544	42002.6
1	13.58	0.00	6.79	224	1521	-	-	-	49388.4

Through the initial lateral force calculations I found that seismic forces control the lateral design. To ensure this assumption, both loading conditions were applied in accordance with ASCE 7-02 to a model of the shear wall system created in ETABS. Full wind loads were applied in all principle and intermediate directions on the building represented in the figure below. This was to account for any design oversights of using a rectilinear simplification of the projected tributary widths in the Analytical Procedure. Equivalent design forces and moments for wind load cases 1-4 were also calculated and applied to the model for a complete wind load analysis.

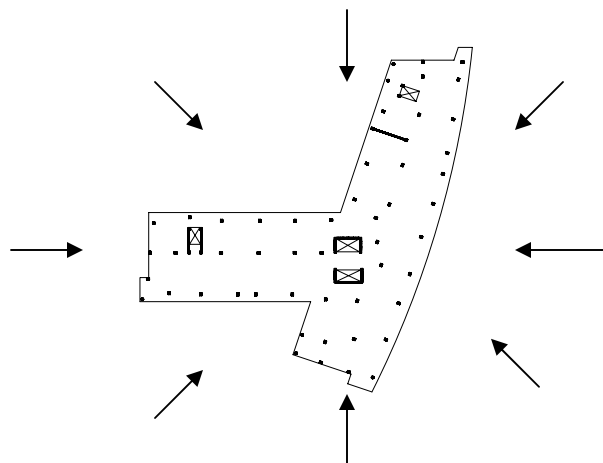



### Shear Wall Analysis

The shear walls were modeled in ETABs and subjected to the applied lateral load cases developed in the previous section. Seismic forces controlled the design and were evaluated in each direction at the center of mass with accidental eccentricity of 5%. I reduced out of plane stiffness to simulate the shear walls as in-plane resisting elements. The flat plate was modeled as a rigid diaphragm without vertical load transfer to appropriately apply the seismic forces calculated with the equivalent lateral force procedure. The model was then analyzed in iterations by extruding the central shear walls on each run and checking the model against the deflection and story drift design limitations.

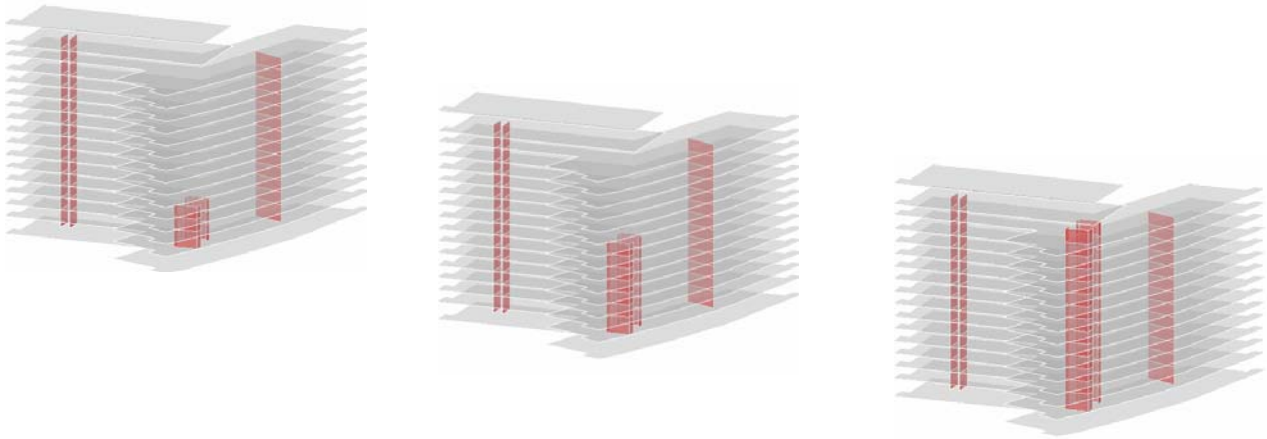

The shear wall systems were first checked for overall displacement of the building at the center of mass of each diaphragm. The irregularity of the building shape created maximum displacements at the extents of the tower wings. These displacements and story drifts would control the design of the shear walls. The control points are depicted in the adjacent figure.

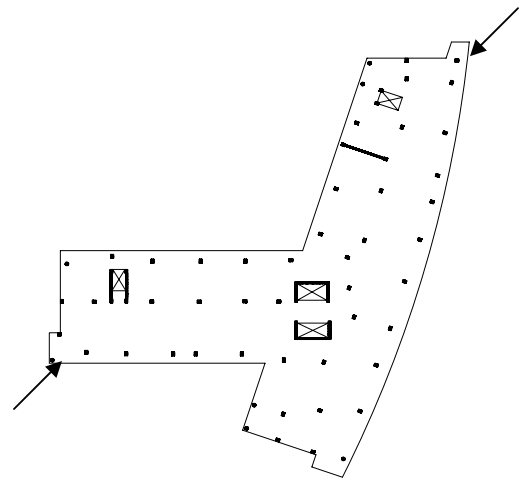

*Maximum Displacement Points*





## The Odyssey Condominium

Aaron Snyder  
Structural Option

The final applicable shear wall design with central shear walls extended to the roof level failed to meet the displacement limitation. The displacement at the diaphragm center of mass reached the design limit at level 6. The total displacement at the roof level was a total of 6", well over the design limit of 3.33". Below are the maximum shear wall design and deflected shape from the seismic loading condition resolved from the forces calculated with the equivalent lateral force procedure.

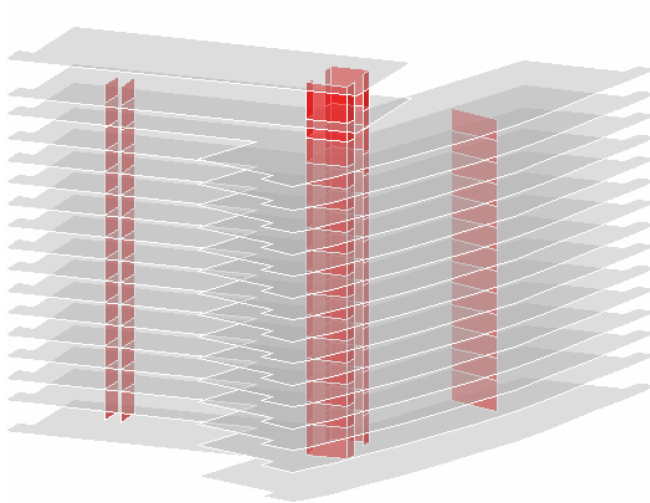

*Shear Walls at Roof Level*

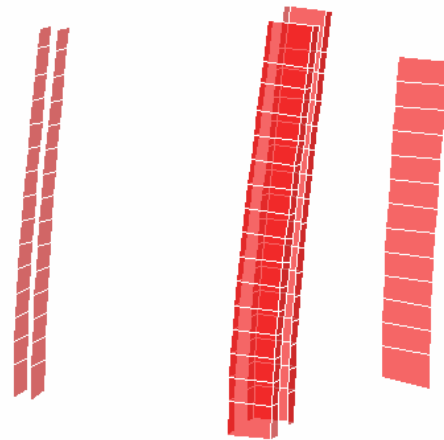

*Deflected Shape*

The alternative for designing an effective shear wall system was adjusting the wall sizes to increase their stiffness until full lateral resistance is achieved. The new design thicknesses would need to cut the current displacements in half and would jeopardize the architectural integrity of the spaces around the walls. Another alternative was to keep the shear wall design and incorporate the designed flat plate system into the lateral design. This would limit added material costs for larger shear walls and the slab frames would contribute effectively in limiting the displacements at the building corners.



### Slab Frame / Shear Wall Analysis

The design of the integrated system would adhere to the criteria and limitations used for the shear wall design. The design advantage of an integrated lateral system composed of shear walls and moment frames lies within the interaction between each system in deflection. The slab frame deflects in shear and tall shear walls deflect predominantly in flexure. A combination system produces opposing internal forces which increase overall stiffness within the system. The resulting deflection of the integrated system is less than individual deflections of each system acting alone. The diagram below depicts the interaction of a moment frame and shear wall system.

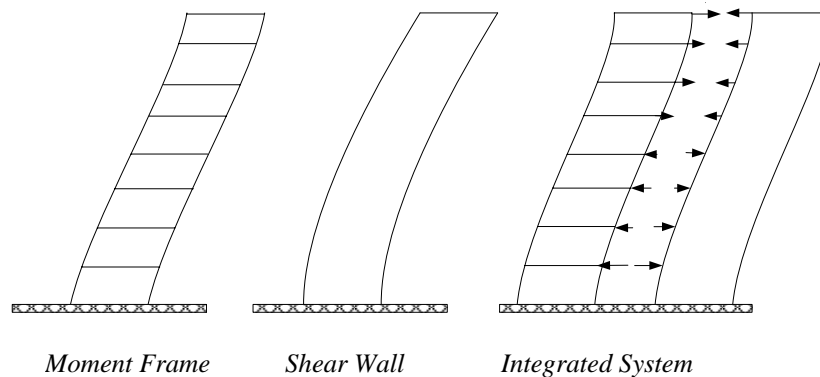

The slab frame system was simulated in the shear wall model as beams with the same structural depth of the flat plate spanned at panel support lines shown to in the figure to the right. The beams were sized to the average effective column width under the assumption that the concrete within this region would effectively contribute to the resistance of shear transfer by lateral forces.

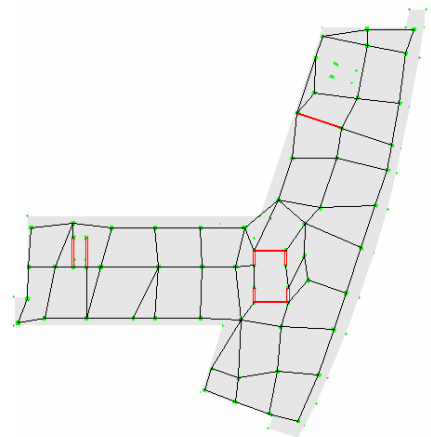

*Simulated Slab Frame System*



## The Odyssey Condominium

Aaron Snyder  
Structural Option

---

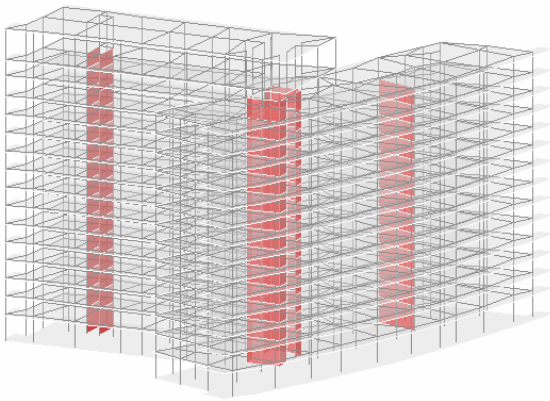

*Shear Wall / Slab Frame System*

I followed the same design procedure with the ETABs model that I used for the shear wall design. The seismic load cases still controlled the displacements and drifts of the integrated system. The influence of the slab frame distributed lateral forces enough to reduce the shear wall design to the 14<sup>th</sup> level. Displacement was met at the H/600 limit at the critical points and story drifts were well under the allowable limit referenced in Appendix D.

### **Summary**

The lateral analysis of the proposed shear wall system needed to be investigated for the induced lateral loads from the flat plate and column redesigns. Added structural weight to the overall building resulted in seismic loads controlling the lateral design. The structural model of the system incorporated wind load design cases to check the assumption of seismic control.

The proposed shear wall design was unable to resist the seismic loads alone. Central walls were extended through the building to the roof level with a displacement of 6", well over the displacement limit of H/600. The flat plate was integrated into the lateral system design to increase the overall stiffness of the structure. Utilizing the flat plate decreased the displacement at critical points on the building corners. The new design of the lateral system would have the central shear walls extended to the 14<sup>th</sup> level with the others to their respective limits at the 14<sup>th</sup> and 15<sup>th</sup> levels. Displacement was reduced to 3" at the roof level meeting the H/600 limit with a story height of 167' measured from the 1<sup>st</sup> level.

# **Construction Study**



- **Cost Comparison**
- **Schedule Comparison**



## Construction Study

### Cost Comparison

The structural redesign of the flat plate system will produce significant implications with the overall construction cost. By observation alone, the proposed reinforced flat plate significantly increased concrete material quantities within the flat plate and columns. The adjustments to the lateral design also resulted in the addition of shear walls through the building. A cost analysis was performed to better understand the cost efficiency of the structural redesign. R.S. Means was used to develop the cost analysis for the system comparison. The analysis was simplified to a typical level for an average square foot cost of the entire tower structure.

Material take-offs for the analysis included the flat plate design, supporting columns, and shear walls on a typical level. The crews used for each system were matched for an equivalent comparison of labor costs and durations. A cost for each structural component was calculated and accumulated for an average cost per 21010 SF. The reinforced flat plate was a more expensive design at \$26/SF, with the post-tensioned system at \$21/SF. The redesign had higher material costs primarily resulting from increases in concrete and reinforcement in the flat plate. The reinforcement material and labor cost alone increased over 100% compared to tendons and reinforcement of the post-tensioned system. A break-down of square foot costs for each design are shown in the following charts and the system take-offs are included on the following pages.

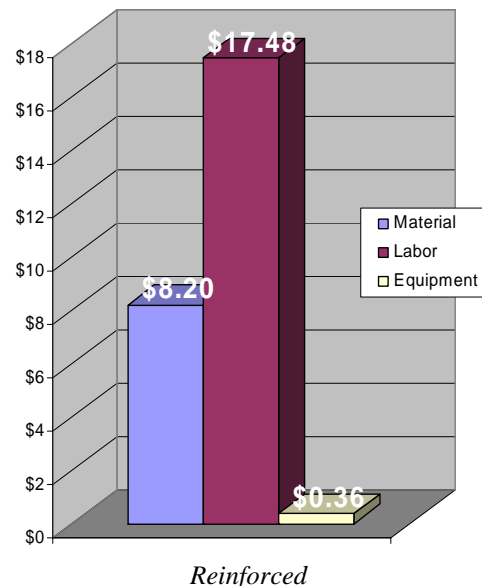
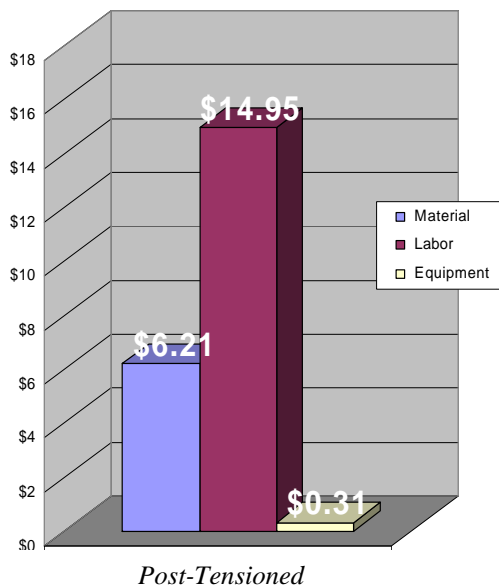



# The Odyssey Condominium

Aaron Snyder  
Structural Option

## Post-Tensioned Flat Plate

Concrete Columns Description	Take-Off Quantity	# of Crews	Crew	Daily Output	Labor Hours	Unit	2006 BARE COSTS				Take-Off Total	Duration (Days)
							Mat.	Labor	Equip.	Total		
Concrete <i>Normal Wt., 5000psi</i>	61.76					C.Y.	96			96	\$5,929	
Concrete in place <i>Average Reinforcing</i>												
18" x 28"	56.15	1	C14A	17.7	11.293	C.Y.	345	385	41	771	\$43,292	3.2
20"	4.52	1	C14A	24	8.316	C.Y.	375	285	30.5	690.5	\$3,121	0.2
24"	1.09	1	C14A	27	7.391	C.Y.	375	253	27	655	\$714	0.0
Placing, w/ Crane & Bucket												
18" x 28"	56.15	1	C-7	70	1.029	C.Y.		31	14.45	45.45	\$2,552	0.8
20"	4.52	1	C-7	60	1.2	C.Y.		37	17	54	\$244	0.1
24"	1.09	1	C-7	70	1.029	C.Y.		31	14.45	45.45	\$50	0.0
											\$55,901	

Concrete Shear-Walls Description	Take-Off Quantity	# of Crews	Crew	Daily Output	Labor Hours	Unit	2006 BARE COSTS				Take-Off Total	Duration (Days)
							Mat.	Labor	Equip.	Total		
Concrete 10" wall <i>Normal Wt., 4000psi</i>	25.14					C.Y.	84			84	\$2,112	
Placing, w/ Crane & Bucket	25.14	1	C-7	85	0.85	C.Y.		24.5	11.35	35.85	\$901	0.3
Reinforcement in Place	1.28	1	4 Rodm	3	10.667	Ton	760	405		1165	\$1,491	0.4
Forms in place, 4 use	1705.6	1	C2	450	0.107	SFCA	0.37	3.56			\$6,703	3.8
Concrete 14" wall <i>Normal Wt., 4000psi</i>	16.12					C.Y.	84			84	\$1,354	
Placing, w/ Crane & Bucket	16.12	1	C-7	95	0.758	C.Y.		22	10.1	32.1	\$517	0.2
Reinforcement in Place	1.22	1	4 Rodm	3	10.667	Ton	760	405		1165	\$1,421	0.4
Forms in place, 4 use	416.8	1	C2	450	0.107	SFCA	0.37	3.56			\$1,638	0.9
											\$14,500	

Concrete Flat Plate Description	Take-Off Quantity	# of Crews	Crew	Daily Output	Labor Hours	Unit	2006 BARE COSTS				Take-Off Total	Duration (Days)
							Mat.	Labor	Equip.	Total		
Concrete <i>Normal Wt., 5000psi</i>	518.8					C.Y.	96			96	\$49,805	
Placing, Elevated Slabs <i>8" thick, w/ Crane &amp; Bucket</i>	518.8	2	C-7	110	0.655	C.Y.		11.9	4.65	16.55	\$14,760	2.4
Reinforcement in place <i>Elevated Slab, #3 to #7</i>	14.2	2	4 Rodm	2.9	11.034	Ton	905	435		1340	\$25,205	2.4
Post-Tensioning, ungrouted <i>50' span, 25k</i>	9025.12	1	C-4	1275	0.025	Lb.	0.47	1	0.02	1.49	\$13,447	7.1
<i>50' span, 300k</i>	9037.6	1	C-4	1475	0.022	Lb.	0.47	0.87	0.02	1.36	\$12,291	6.1
Concrete in place, Flat Plate <i>Forms (4 uses), Strip</i>	20800	4	C2	560	0.086	S.F.	1.3	2.86		4.16	\$264,992	9.3
											\$380,500	

Total Cost \$450,902

Cost/S.F. \$21







---

### Schedule Comparison

The construction schedules were also investigated for a comparison of the designs. The flat plate designs will have similar construction sequences for formwork, reinforcement placement, and concrete placement. The construction sequence of a typical residential level will be completed in three equally sized floor sections. A sectioned construction sequence will increase the rate of floor completion by limiting multiple trades working in the same section at once. The floor sections are depicted below and are referenced by their respective column lines in the schedules included on the following pages.

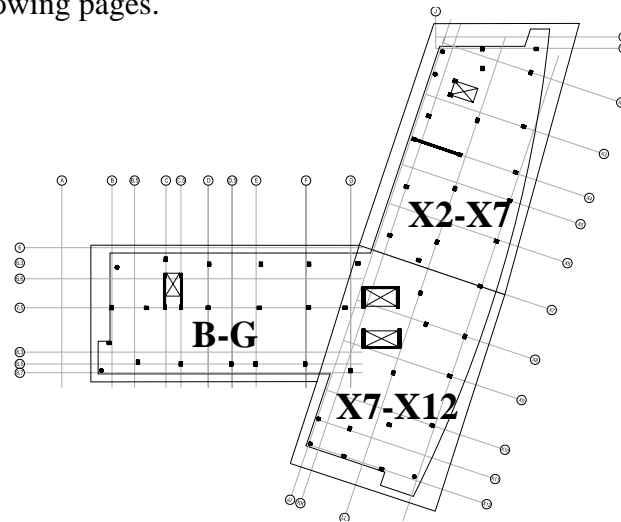

Schedule issues of the post-tensioned design include the placement and jacking of the post-tensioned tendons. The tendons need to be draped throughout the floor plan with precision adding construction time and labor costs. Also, the removal of formwork and jacking of tendons is only permitted after the concrete plate has reached 75% of its 28 day strength. The durations for completing each section were resolved from the daily output calculated in the cost analysis. The components were given a total duration for the forming, reinforcing, and placement of concrete denoted (F/R/P) in the schedules. The slab was given a cure time of two days until it was post-tensioned and the formwork was removed. A construction schedule over three levels was created for each system to determine an average duration. The post-tensioned system required 8 days to complete an entire floor and the reinforced flat plate system required 7. The extended construction schedule was the result of added duration time for tendon placement and tensioning.



# The Odyssey Condominium

Aaron Snyder  
Structural Option

## Post-Tensioned Flat Plate

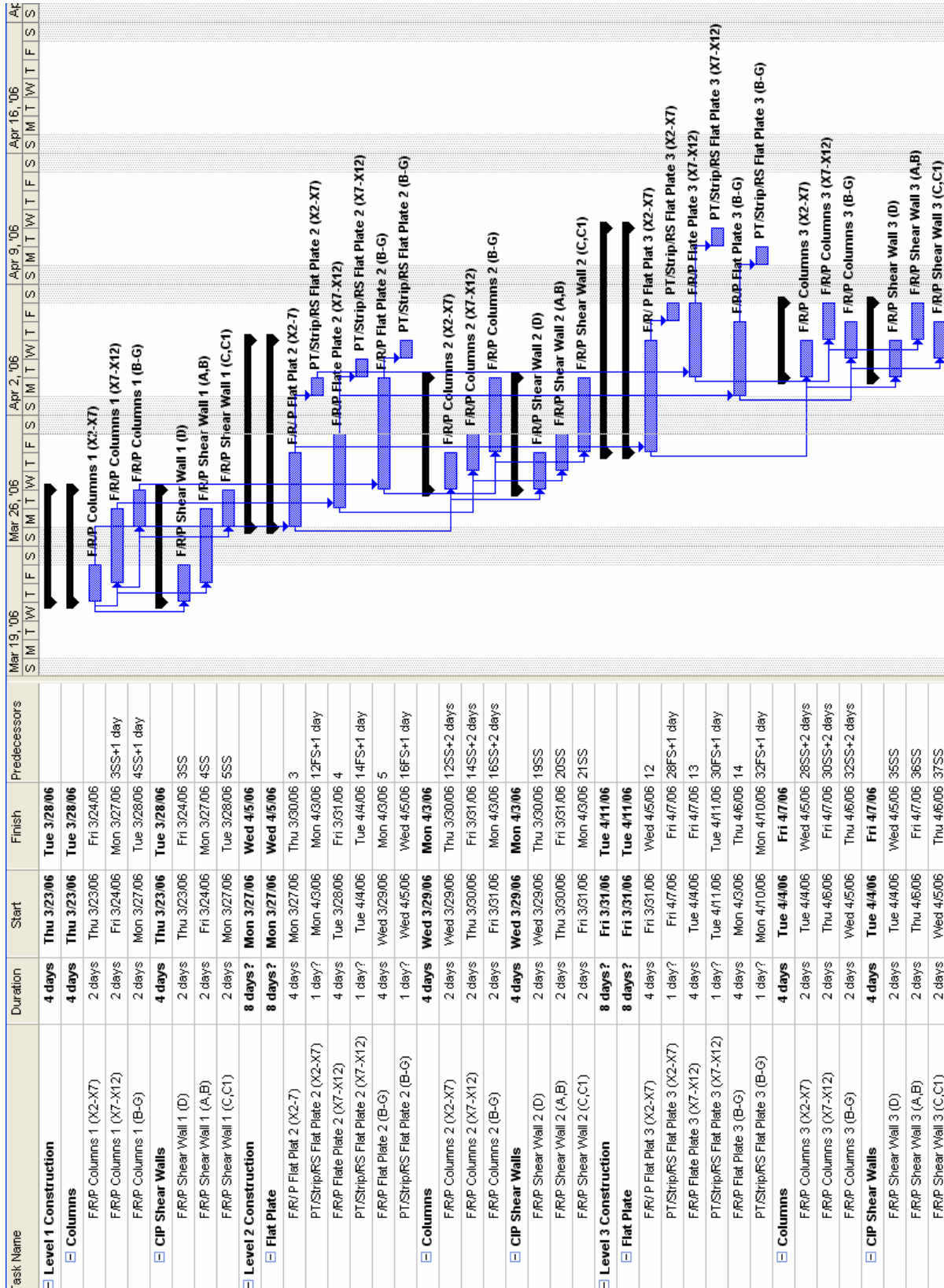



# The Odyssey Condominium

Aaron Snyder  
Structural Option

## Reinforced Flat Plate

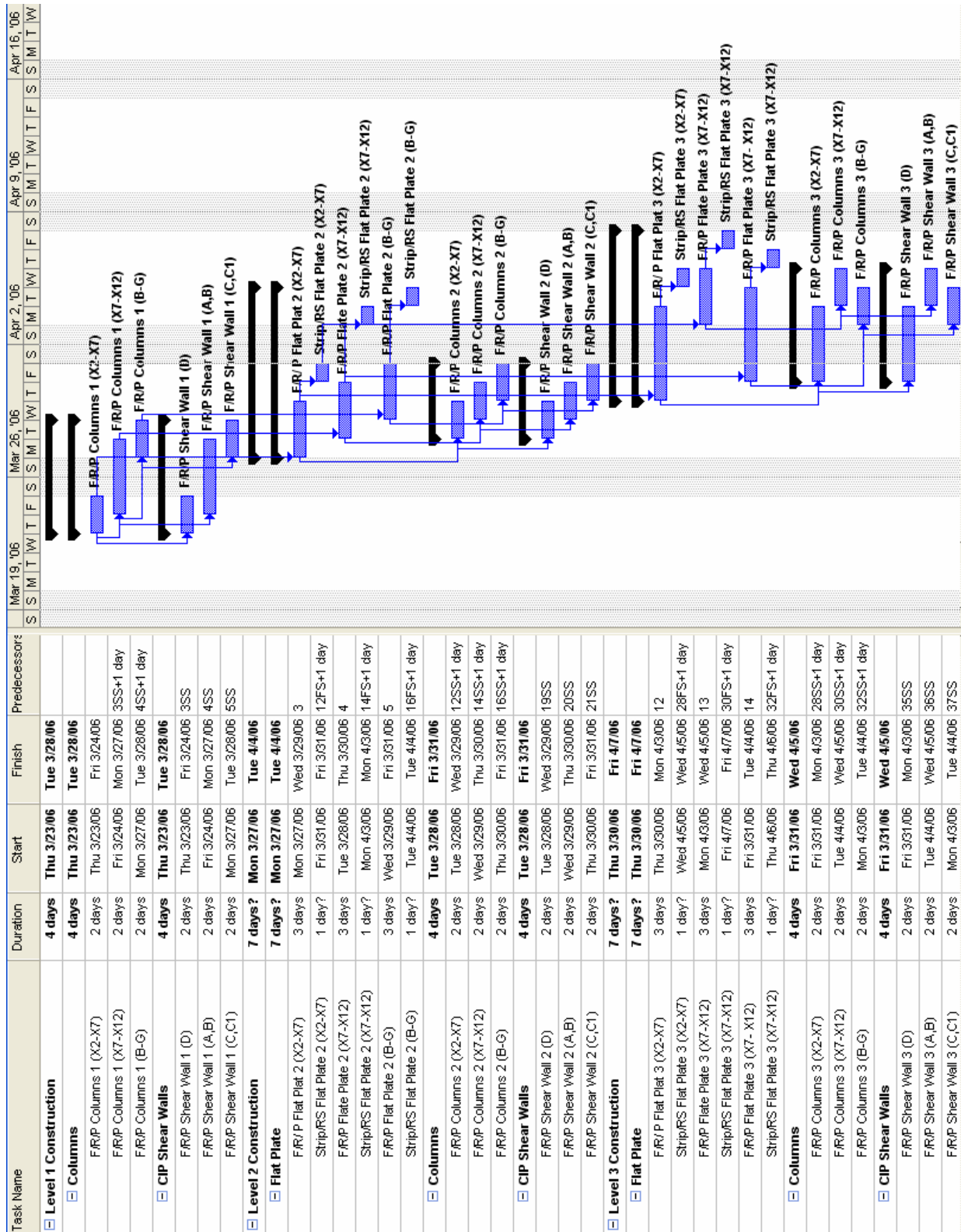

# **Building Envelope Study**





## Building Envelope Study

### Introduction

The building envelope of the Odyssey contains full height curtain walls sections matched with a brick veneer and punch window scheme. Curtain walls were added to the design early in the design phase when Monument Realty upgraded the building status from apartments to luxury condominiums. The curtain walls are a prestigious architectural feature of the prominent East face of the building overlooking downtown Arlington and the Washington Mall. The picture below shows the East elevation with the curtain walls and the brick veneer with punch windows on the remaining elevations.



*East Elevation*

### Design Criteria

The objective of the building envelope breadth study was evaluating the thermal efficiency of each design. A comparison between the systems would determine if the curtain wall is a reasonable design to maintain the thermal integrity of the envelope. Thermal properties of each typical wall section were selected in accordance with design specifications of ASHRAE Fundamentals 2001. Each wall assembly will be simulated in conditioned spaces with identical design criteria. The control space will alleviate any mechanical system discrepancies and allow for the direct observation and comparison between the thermal efficiencies of the envelope designs.





### Curtain Wall Assembly

The curtain wall is the series 5900 Outside Glazed Curtain Wall System product of the EFCO Corporation. The overall system depth is 8" measured from the face of the aluminum mullions. The curtain wall is glazed with a 1" glass unit composed of interior 1/4" clear annealed glass with a low-emissivity soft coat, a 1/2" air space, and exterior 1/4" clear annealed glass. The curtain walls are thermally improved using EPDM gasket at the glazing interface to isolate exterior and interior air extrusions. The gasket is shown below in a vertical mullion section. The thermal resistance (R) and total calculated thermal transmittances (U) are listed below for the wall component and curtain wall system. A section of the curtain wall assembly is shown to the right with the wall component located at the bottom of the wall assembly.

### Curtain Wall Assembly

<u>Wall Component</u>	<u>thickness</u> (in)	<u>Resistance (R)</u> (h ft <sup>2</sup> °F/ BTU)
<b>Outside Surface</b> 15 mph		0.17
<b>Ext Metal Panel</b> med. wt. - 125pcf	-	Negl.
<b>Air Space</b> $\epsilon_{\text{eff}} = 0.25$ (metal, batt) $\mu_{\text{temp}} = 50^\circ\text{F}$ $\Delta T = 30^\circ\text{F}$ vertical position	3 1/2"	1.78
<b>Batt Insulation</b>	2 1/2"	8
<b>Vapor Seal</b>	-	Negl.
<b>Fire Cont. Insulation</b>	1 1/2"	Negl.
<b>Metal Stud Backup</b>	2 1/2"	Negl.
<b>Int. Gyp Board</b>	1/2"	0.45
<b>Inside Surface</b> Still air		0.685

Resistance  $\Sigma R = 11.1$

U-Factor  $U = 0.0902$

### Outside Glazed Curtain Wall System

EFCO Series 5900 - Thermal

$U = 0.47$

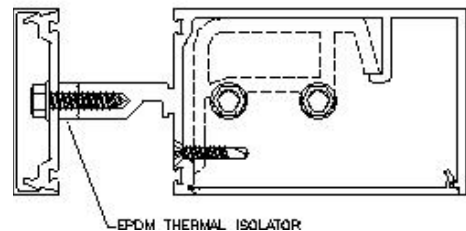



# The Odyssey Condominium

Aaron Snyder  
Structural Option

## Brick Veneer / Window Assembly

The standard building envelope has a 4" brick veneer with stud wall backup and horizontal sliding windows. The windows are series 3500 Thermal HS-AW50 Grade Horizontal Sliding Windows which are also a product of the EFCO Corporation. Thermal barriers in the heads, jambs, and sills are high density polyurethane and thermal struts consisting of glass reinforced polyamide nylon. Thermal strut locations in the sill are depicted in the mullion section below.

The thermal resistance (R) and total calculated thermal transmittances (U) are listed below for the wall component and sliding windows. A typical section of the brick veneer and window assembly is shown to the right.

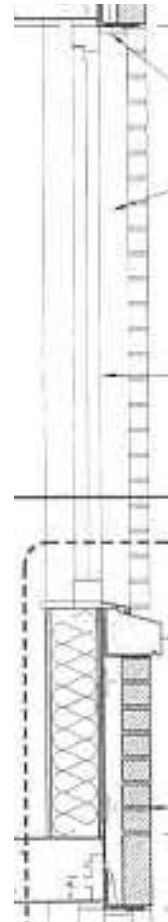

## Brick Veneer / Window Assembly

<u>Wall Component</u>	<u>thickness</u> (in)	<u>Resistance ( R )</u> (h ft <sup>2</sup> °F/ BTU)
<b>Outside Surface</b> 15 mph		0.17
<b>Brick Veneer</b> med. wt. - 125pcf	4"	0.64
<b>Air Space</b> $\epsilon_{\text{eff}} = 0.82$ (masonry) $H_{\text{temp}} = 50^{\circ}\text{F}$ $\Delta T = 30^{\circ}\text{F}$ vertical position	2 1/2"	0.9
<b>Vapor Seal</b>	-	Negl.
<b>Ext. Grade Sheathing</b>	5/8"	1.65
<b>Metal Stud Backup</b>	6"	Negl.
<b>Batt Insulation</b>	6"	19
<b>Int. Gyp Board</b>	1/2"	0.45
<b>Inside Surface</b> Still air		0.685

Resistance  $\Sigma R = 23.5$

U-Factor  $U = 0.0426$

### Horizontal Sliding Windows

EFCO Series 3500 - Thermal

$U = 0.56$

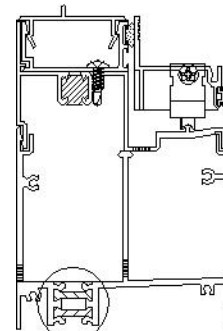

Thermal struts





### Thermal Analysis

The building envelopes were modeled over a typical 421 ft<sup>2</sup> tributary area of the curtain wall system on the East elevation. The brick veneer and sliding window model contained 8 windows, each with a coverage area of 24 ft<sup>2</sup>. The Carrier Hourly Analysis Program 4.2 (HAP) was used to simulate the thermal efficiencies of the walls with the assumed space criteria listed below.

- Gross Floor Area: 1250 ft<sup>2</sup>
- Ceiling Height: 8'-8"
- Occupancy: 4
- Activity Level: Sedentary Work
- Lighting / Electrical 1 W/ft<sup>2</sup> / 5 W/ft<sup>2</sup>
- Hourly Load Schedule →

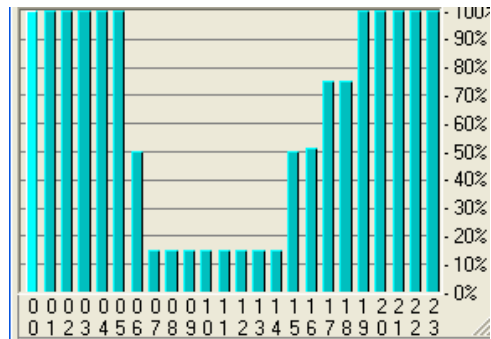

I simulated a variable air volume (VAV) mechanical system instead of the individual heat pump systems used in the Odyssey. The alteration does not affect the efficiency study of the building envelopes. The calculated design heating and cooling loads will only be checked against each other for a comparative efficiency of the envelope systems and will not be regarded as the actual design loads for the space.

### Conclusions

I calculated the efficiency of the curtain wall for envelope and space loads from the results of the HAP simulation. The thermal efficiencies of the curtain wall are listed to the right with an average loss of 18.5 % compared to the brick veneer and window assembly. These losses incur additional costs in the mechanical design requirements to maintain thermal control of the space. The curtain wall may add an architectural statement to the building envelope; however it will not maintain a reasonable thermal integrity with the remaining building envelope.

#### Envelope Loads:

<u>Cooling Transmission</u> (BTU/hr)	- 20.0 %
<u>Heating Transmission</u> (BTU/hr)	- 22.4 %

#### Space Loads:

<u>Cooling Load</u> (MBH)	- 9.30 %
<u>Heating Load</u> (MBH)	- 22.6 %

# **Conclusion**





## Conclusion

The objective of this study was to evaluate the design implications of incorporating an alternative system into the design scheme of a two-way post-tensioned flat plate. The proposed criteria of the redesign included maintaining the architectural integrity of the residential spaces without exceeding the overall building height limitation. The reinforced flat plate redesign met these criteria providing a flat ceiling surface without obstructions to mechanical soffits. Ceiling heights within residential units were also maintained without exceeding the building height limit.

Design implications of the reinforced flat plate included the increased structural depth to accommodate for the large span to depth ratios achieved in the post-tensioned design. Structural costs were higher with a majority of the cost difference from additional reinforcement required in the redesign of the flat plate. The flat plate thickness also impacted the gravity and lateral system designs of the building. Column dimensions increased as well as the required specified concrete strength to maintain a uniform column size throughout the building. The proposed system also increased building weight resulting in a design adjustment to the proposed shear wall system. The flat plate was incorporated into the lateral design with required additions to the central shear walls to meet displacement and story drift limits. The average duration for the completion of a typical level was shortened without the added construction time of placing and jacking the post-tensioning. Although the proposed system met the design criteria, the overall structural design of the building and associated costs are more feasible with a two-way post-tensioned flat plate design.



## **Credits / Acknowledgements**

I would like to extend my gratitude to everyone who has given me guidance and mentoring throughout the duration of this project: I would like to acknowledge and thank the Architectural Engineering Department for their encouragement and support in helping me achieve my academic goals. I would also like to thank the design professionals that imparted on me their knowledge and expertise of structural design and construction.

### **Penn State Architectural Engineering Department:**

Professor M. Kevin Parfitt

Dr. Linda Hanagan

Dr. Thomas Boothby

### **Ehlert / Bryan Inc.**

Jason Sparrow

### **Donohoe Construction Co.**

Jon Peterson

A special thanks to my fellow AE students who helped me along these last five years at Penn State. I would also like to thank Stephanie for her patience and support through thick and thin. Finally, I would like to thank my family for their enduring love and encouragement. Thank you.



## References

- International Building Code, IBC 2003
- ACI 318 – 05, Building Code Requirements for Structural Concrete and Commentary
- Nilson, Arthur H. *Design of Concrete Structures*, 13<sup>th</sup> ed. 2004
- Alami, Dr. Bijan O. *PTI Technical Notes: Design of Concrete Floors*. Issue 11, Jan 2001
- VSL International Ltd. *Post-Tensioned in Buildings*. Report Series, v4.1 1992
- ASHRAE Handbook 2001, Fundamentals
- Stein, Benjamin. *Mechanical and Electrical Equipment for Buildings*, 9<sup>th</sup> ed. 2000
- R.S. Means Construction Cost Data, 2005

# Appendix





## Appendix A – Lateral Loads

### Wind Load Analysis

Building Properties	
B (ft)	222
L (ft)	224
h (ft)	171.00
$K_{zt}$	1
$K_d$	0.85
V (mph)	80
Importance	I
$I_w$	1
Exposure	B
$\square$	7
$z_g$	1200
$z_{min}$	100.2
c	0.3
$\epsilon$	0.333333
/	320
$\delta$	0.450
$\beta$	0.25
$\underline{a}$	0.143
$\underline{b}$	0.84

Fundamental Period	
Struct. Type	Concrete
$C_t$	0.02
x	0.75
T	0.945752
Natural $f$	1.05736
Rigidity	Rigid

Rigid	
$g_u, g_v$	3.40
$\dot{z}$	102.60
$l_z$	0.25
$L_z$	467.05
Q	0.80
G	0.85

Windward	
$C_p$	0.8

Pressure Coefficients		
Internal		
Enc. Type	Enclosed	
Internal ( $GC_{pi}$ )	0.18	+/-

Pressures			
Windward	N-S	$P_z$	0.680
	E-W	$P_z$	0.680
Leeward	N-S	$P_h$	-0.425
	E-W	$P_h$	-0.423

Leeward		
Ratio	$C_p$	
N-S	0.991	-0.50
E-W	1.009	-0.50

$K_z$ and $q_z$		
Z(ft)	$K_z$	$q_z$
0-15	0.57	7.94
20	0.62	8.63
25	0.66	9.19
30	0.70	9.75
40	0.76	10.58
50	0.81	11.28
60	0.85	11.84
70	0.89	12.39
80	0.93	12.95
90	0.96	13.37
100	0.99	13.79
120	1.04	14.48
140	1.09	15.18
160	1.13	15.74
180	1.17	16.29

Z(ft)	Windward		Leeward		Total MWFRS	
	N-S	E-W	N-S	E-W	N-S	E-W
0-15	5.40	5.40	-6.76	-6.73	12.16	12.13
20	5.87	5.87	-6.76	-6.73	12.63	12.61
25	6.25	6.25	-6.76	-6.73	13.01	12.98
30	6.63	6.63	-6.76	-6.73	13.39	13.36
40	7.20	7.20	-6.76	-6.73	13.96	13.93
50	7.67	7.67	-6.76	-6.73	14.43	14.41
60	8.05	8.05	-6.76	-6.73	14.81	14.78
70	8.43	8.43	-6.76	-6.73	15.19	15.16
80	8.81	8.81	-6.76	-6.73	15.57	15.54
90	9.09	9.09	-6.76	-6.73	15.85	15.83
100	9.38	9.38	-6.76	-6.73	16.13	16.11
120	9.85	9.85	-6.76	-6.73	16.61	16.58
140	10.32	10.32	-6.76	-6.73	17.08	17.06
160	10.70	10.70	-6.76	-6.73	17.46	17.44
180	11.08	11.08	-6.76	-6.73	17.84	17.81





# The Odyssey Condominium

Aaron Snyder  
Structural Option

## Vertical Distribution of Wind Forces

Wind Loading ( N-S )

Level	Story Height (ft.)	Elevation (ft.)	Tributary Height (ft.)	Tributary Width (ft.)	Tributary Area (ft <sup>2</sup> )	Wind Load (psf)	Wind Load (k)	Shear (k)	Moment (ft - k)
Roof	4	166.74	12.00	183	2196	17.6	39	39	-
16	16	150.74	13.63	183	2493	17.3	43	82	617.3
15	11.25	139.49	11.08	183	2028	17.1	35	117	1537.8
14	10.91	128.58	10.25	224	2295	16.9	39	155	2809.6
13	9.58	119.00	9.58	224	2147	16.7	36	191	4297.8
12	9.58	109.41	9.58	224	2147	16.4	35	226	6129.0
11	9.58	99.83	9.58	224	2147	16.2	35	261	8297.7
10	9.58	90.25	9.58	224	2147	15.9	34	295	10799.8
9	9.58	80.66	9.58	224	2147	15.6	34	329	13629.1
8	9.58	71.08	9.58	224	2147	15.3	33	362	16779.9
7	9.58	61.50	9.58	224	2147	14.9	32	394	20245.1
6	9.58	51.91	9.58	224	2147	14.6	31	425	24017.5
5	9.58	42.33	9.58	224	2147	14.1	30	455	28089.3
4	9.58	32.75	9.58	224	2147	13.6	29	484	32451.9
3	9.58	23.16	9.58	224	2147	12.9	28	512	37094.2
2	9.58	13.58	11.58	224	2594	12.2	32	544	42002.6
1	13.58	0.00	6.79	224	1521	-	-	-	49388.4

Wind Loading ( E-W )

Level	Story Height (ft.)	Elevation (ft.)	Tributary Height (ft.)	Tributary Width (ft.)	Tributary Area (ft <sup>2</sup> )	Wind Load (psf)	Wind Load (k)	Shear (k)	Moment (ft - k)
Roof	4	166.74	12.00	62	744	17.6	13	13	-
16	16	150.74	13.63	62	845	17.3	15	28	208.9
15	11.25	139.49	11.08	62	687	17.1	12	39	520.4
14	10.91	128.58	10.25	222	2275	16.9	38	78	950.8
13	9.58	119.00	9.58	222	2127	16.7	35	113	1696.2
12	9.58	109.41	9.58	222	2127	16.4	35	148	2781.0
11	9.58	99.83	9.58	222	2127	16.0	34	182	4200.0
10	9.58	90.25	9.58	222	2127	15.9	34	216	5945.2
9	9.58	80.66	9.58	222	2127	15.6	33	249	8014.4
8	9.58	71.08	9.58	222	2127	15.3	32	282	10401.9
7	9.58	61.50	9.58	222	2127	14.9	32	313	13100.5
6	9.58	51.91	9.58	222	2127	14.5	31	344	16103.1
5	9.58	42.33	9.58	222	2127	14.1	30	374	19402.1
4	9.58	32.75	9.58	222	2127	13.6	29	403	22988.8
3	9.58	23.16	9.58	222	2127	12.9	27	431	26852.4
2	9.58	13.58	11.58	222	2571	12.0	31	461	30979.2
1	13.58	0.00	6.79	222	1507	-	-	-	37246.0



# The Odyssey Condominium

Aaron Snyder  
Structural Option

## Seismic Analysis

Equivalent Lateral Force Procedure

ASCE7-02

Section 9

### Design Parameters

Location:	Arlington, Virginia	
Number of Stories:	N = 16	
Inner Story Height:	hs = varies - 9'-7" typ.	
Building Height:	hn = 171	
Seismic Use Group:	1	Table: 9.1.3
Occupancy Importance:	I = 1.0	Table: 9.1.4
Site Classification:	C	9.4.1.2
Accelerations:		
0.2 s	Ss = 0.179	Figure: 9.4.1.1(a)
1.0 s	S1 = 0.063	Figure: 9.4.1.1(b)
Site Class Factor:	Fa = 1.2	Table: 9.4.1.2(a)
	Fv = 1.7	Table: 9.4.1.2(b)
Adjusted Accelerations:	Sms = 0.2148	9.4.1.2.4-1
(max.)	Sm1 = 0.1071	9.4.1.2.4-2
Design Spectral Response	S <sub>DS</sub> = 0.143	9.4.1.2.5-1
Accelerations:	S <sub>D1</sub> = 0.0714	9.4.1.2.5-2
Seismic Design Category:	B	9.4.2.1(a/b)
Response Modification:	R = 5	Table: 9.5.2.2
Deflection Modification:	Cd = 4.5	

### Weight of Floor (w<sub>x</sub>) and Total Weight (W)

	Area (SF)	Perimeter (ft)	Total q (PSF)	Weight (Kips)	Total Wt. (w <sub>x</sub> ) (Kips)
Main Roof	6100	502	187.5	1336.52	1847.52
Roof: Pool Terrace	10000	515	187.5	1964.90	2129.90
Floor: Level 16	9711	502	300	3170.32	3550.32
Floor: Level 15	9711	502	164.5	1778.18	2178.18
Level 14	19453	850	164.5	3496.77	4096.77
Level 13	20581	850	164.5	3646.24	4246.24
Levels 2-12	21010	850	164.5	3716.81	47484.92
Level 1	18476	850	164.5	-	
				$W = \sum w_x =$	65533.85

add: Cols/Walls  
Misc. Equip

wt./floor 2-12  
4316.81

q <sub>wall</sub> (PSF)
32

exp. K k; .5 ? Ta ? 2.5
1.21

E-W

Base Shear (Kips) V = Cs * W	Cs	Level	hs (ft)
	0.0286	1	13.58
1008.4	Ta	2 - 13	9.5833
	0.93	14	10.91
N-S		15	11.25
	Base Shear (Kips) V = Cs * W	Cs (?)	16
1008.4	0.0154	Roof	4
	Cs (?)		
	0.0063		



# The Odyssey Condominium

Aaron Snyder  
Structural Option

## Vertical Distribution of Seismic Forces

N-S Level, x	$w_x$ (kips)	$h_x$ (ft)	$w_x h_x^k$	$C_{vx}$	Load	Shear	Moment
					$F_x$ (kips)	$V_x$ (kips)	$M_x$ (ft-kips)
Roof	1848	166.74	920,817	0.064	64		10,736
16	3550	150.74	1,565,543	0.109	109	64	16,502
15	4308	139.5	1,729,115	0.120	121	174	16,867
14	4097	128.58	1,489,378	0.103	104	295	13,391
13	4317	119	1,428,576	0.099	100	399	11,888
12	4317	109.413	1,290,086	0.089	90	499	9,870
11	4317	99.8297	1,154,223	0.080	81	589	8,057
10	4317	90.2464	1,021,127	0.071	71	670	6,444
9	4317	80.66	890,985	0.062	62	741	5,025
8	4317	71.08	764,201	0.053	53	803	3,798
7	4317	61.5	641,033	0.044	45	857	2,757
6	4317	51.9132	521,834	0.036	36	902	1,894
5	4317	42.33	407,319	0.028	28	938	1,206
4	4317	32.7466	298,259	0.021	21	967	683
3	4317	23.163	195,903	0.014	14	988	317
2	4317	13.58	102,451	0.007	7	1,001	97
1						1,008	
	∑ 65604		∑ 14420849	∑ 1.000	∑ 1008		∑ 109534

E-W Level, x	$w_x$ (kips)	$h_x$ (ft)	$w_x h_x^k$	$C_{vx}$	Load	Shear	Moment
					$F_x$ (kips)	$V_x$ (kips)	$M_x$ (ft-kips)
Roof	1848	166.74	920,817	0.064	64		10,736
16	3550	150.74	1,565,543	0.109	109	64	16,502
15	4308	139.5	1,729,115	0.120	121	174	16,867
14	4097	128.58	1,489,378	0.103	104	295	13,391
13	4317	119	1,428,576	0.099	100	399	11,888
12	4317	109.413	1,290,086	0.089	90	499	9,870
11	4317	99.8297	1,154,223	0.080	81	589	8,057
10	4317	90.2464	1,021,127	0.071	71	670	6,444
9	4317	80.66	890,985	0.062	62	741	5,025
8	4317	71.08	764,201	0.053	53	803	3,798
7	4317	61.5	641,033	0.044	45	857	2,757
6	4317	51.9132	521,834	0.036	36	902	1,894
5	4317	42.33	407,319	0.028	28	938	1,206
4	4317	32.7466	298,259	0.021	21	967	683
3	4317	23.163	195,903	0.014	14	988	317
2	4317	13.58	102,451	0.007	7	1,001	97
1						1,008	
	∑ 65604		∑ 14420849	∑ 1.000	∑ 1008		∑ 109534



# The Odyssey Condominium

Aaron Snyder  
Structural Option

## Appendix B – Reinforcement Design Table

### Col\_Line X5

### Rebar Design

Location MAX / U Moment (ft-k)	Strip	% (Gamma)	Design Moment (ft-k)	Total width (ft)	Moment/foot of width (ft-k/ft)	Size (#)	S (in)	Quantity	
								Total	C.S./M.S.
Support	1	Column Strip	0.98	169.4	11.8	6	12	12	12
69		Unbalanced $M_f$	0.57	39.3	4.3	6	12	4	
172.9		Middle Strip	0.02	3.5	12.7	6	18	8	8
Span	2	Column Strip	0.60	95.9	12.25	4	12	12	12
159.8		Middle Strip	0.40	63.9	12.25	4	12	12	12
Support	2	Column Strip	0.75	248.9	10.5	6	8	16	16
59.5		Unbalanced $M_f$	0.63	37.5	4.9	6	8	7	
331.8		Middle Strip	0.25	83.0	10.5	6	18	7	7
Span	3	Column Strip	0.60	132.0	10.5	4	8	16	16
220		Middle Strip	0.40	88.0	10.5	4	12	11	11
Support	3	Column Strip	0.98	216.5	8.7	6	10	10	12
205.3		Unbalanced $M_f$	0.57	117.0	4.3	6	8	6	
220.9		Middle Strip	0.02	4.4	8.7	6	18	6	6

$$A_{min} = .0018bd$$

$$24 \text{ in}^2/\text{ft}$$

$$A_{max} = .008bd$$

$$1.056 \text{ in}^2/\text{ft}$$

### Col\_Line X5

### Rebar Design

Location MAX / U Moment (ft-k)	Strip	% (Gamma)	Design Moment (ft-k)	Total width (ft)	Moment/foot of width (ft-k/ft)	Size (#)	S (in)	Quantity	
								Total	C.S./M.S.
Support	1	Column Strip	0.98	169.4	11.8	7	18	8	8
69		Unbalanced $M_f$	0.57	39.3	4.3	7	0		
172.9		Middle Strip	0.02	3.5	12.7	7	18	8	8
Span	2	Column Strip	0.60	95.9	12.25	5	12	12	12
159.8		Middle Strip	0.40	63.9	12.25	5	12	12	12
Support	2	Column Strip	0.75	248.9	10.5	7	18	7	7
59.5		Unbalanced $M_f$	0.63	37.5	4.9	7	0		
331.8		Middle Strip	0.25	83.0	10.5	7	18	7	7
Span	3	Column Strip	0.60	132.0	10.5	5	12	11	11
220		Middle Strip	0.40	88.0	10.5	5	12	11	11
Support	3	Column Strip	0.98	216.5	8.7	7	16	7	8
205.3		Unbalanced $M_f$	0.57	117.0	4.3	7	12	4	
220.9		Middle Strip	0.02	4.4	8.7	7	18	6	6

$$A_{min} = .0018bd$$

$$24 \text{ in}^2/\text{ft}$$

$$A_{max} = .008bd$$

$$1.056 \text{ in}^2/\text{ft}$$

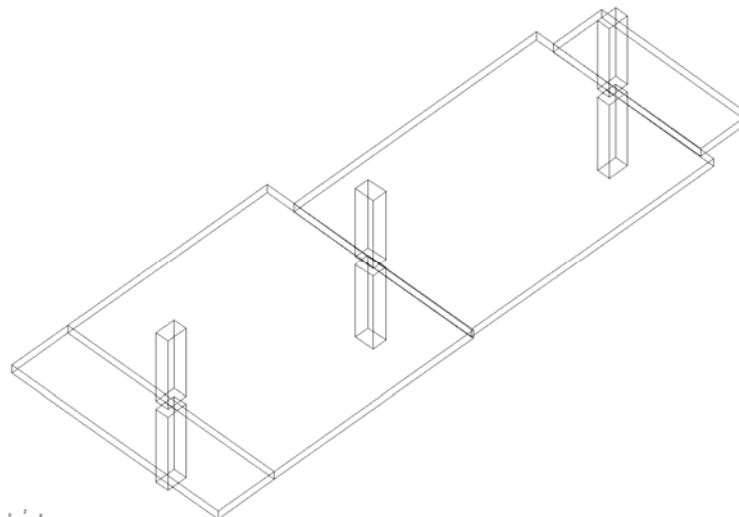



# The Odyssey Condominium

Aaron Snyder  
Structural Option

## Appendix C – Column Load Take-Down Tables

			Column E7.5 Interior				$K_{LL} = 4$		
Level/Column:	Live (PSF)	Dead (PSF)	Area (ft <sup>2</sup> )	$A_T$ (ft <sup>2</sup> )	Reduction	Live Load (kip)	Reducd LL (kip)	Dead Load (kip)	Factord Load (kip)
Roof	30	50	700	700	1.000	21.0	21.0	139.9	201.5
16	150	150	700	1400	0.450	126.0	56.8	347.5	507.8
15	100	27	700	2100	0.414	196.0	81.1	468.6	692.0
14	100	27	700	2800	0.400	266.0	106.4	588.9	877.0
13	100	27	700	3500	0.400	336.0	134.4	709.3	1066.2
12	100	27	700	4200	0.400	406.0	162.4	829.6	1255.4
11	100	27	700	4900	0.400	476.0	190.4	950.0	1444.6
10	100	27	700	5600	0.400	546.0	218.4	1070.3	1633.8
9	100	27	700	6300	0.400	616.0	246.4	1190.6	1823.0
8	100	27	700	7000	0.400	686.0	274.4	1311.0	2012.2
7	100	27	700	7700	0.400	756.0	302.4	1431.3	2201.4
6	100	27	700	8400	0.400	826.0	330.4	1551.7	2390.6
5	100	27	700	9100	0.400	896.0	358.4	1672.0	2579.8
4	100	27	700	9800	0.400	966.0	386.4	1792.3	2769.1
3	100	27	700	10500	0.400	1036.0	414.4	1912.7	2958.3

			Column F7.5 Interior				$K_{LL} = 4$		
Level/Column:	Live (PSF)	Dead (PSF)	Area (ft <sup>2</sup> )	$A_T$ (ft <sup>2</sup> )	Reduction	Live Load (kip)	Reducd LL (kip)	Dead Load (kip)	Factrd Load (kip)
Roof	30	50	554	554	1.000	16.6	16.6	112.5	161.6
16	150	150	554	1108	0.475	99.7	47.4	278.1	409.6
15	100	27	554	1662	0.434	155.1	67.3	375.2	558.0
14	100	27	554	2216	0.409	210.5	86.2	471.6	703.7
13	100	27	554	2770	0.400	265.9	106.4	567.9	851.6
12	100	27	554	3324	0.400	321.3	128.5	664.2	1002.7
11	100	27	554	3878	0.400	376.7	150.7	760.5	1153.7
10	100	27	554	4432	0.400	432.1	172.8	856.8	1304.8
9	100	27	554	4986	0.400	487.5	195.0	953.2	1455.8
8	100	27	554	5540	0.400	542.9	217.2	1049.5	1606.9
7	100	27	554	6094	0.400	598.3	239.3	1145.8	1757.9
6	100	27	554	6648	0.400	653.7	261.5	1242.1	1909.0
5	100	27	554	7202	0.400	709.1	283.6	1338.5	2060.0
4	100	27	554	7756	0.400	764.5	305.8	1434.8	2211.0
3	100	27	554	8310	0.400	819.9	328.0	1531.1	2362.1
2	100	27	554	8864	0.400	875.3	350.1	1627.4	2513.1

			Column C5B.5 Exterior w/ Cantilever + Ext. Wall				$K_{LL} = 3$		
Level/Column:	Live (PSF)	Dead (PSF)	Area (ft <sup>2</sup> )	$A_T$ (ft <sup>2</sup> )	Reduction	Live Load (kip)	Reducd LL (kip)	Dead Load (kip)	Factrd Load (kip)
Roof	30	50	460	460	1.000	13.8	13.8	94.9	136.0
16	150	150	460	920	0.536	82.8	44.3	233.5	351.1
15	100	27	460	1380	0.483	128.8	62.2	315.1	477.7
14	100	27	460	1840	0.452	174.8	79.0	396.0	601.6
13	100	27	460	2300	0.431	220.8	95.1	476.8	724.3
12	100	27	460	2760	0.415	266.8	110.7	557.7	846.3
11	100	27	460	3220	0.403	312.8	125.9	638.6	967.8
10	100	27	460	3680	0.400	358.8	143.5	719.4	1092.9
9	100	27	460	4140	0.400	404.8	161.9	800.3	1219.4
8	100	27	460	4600	0.400	450.8	180.3	881.1	1345.9
7	100	27	460	5060	0.400	496.8	198.7	962.0	1472.4
6	100	27	460	5520	0.400	542.8	217.1	1042.9	1598.8
5	100	27	460	5980	0.400	588.8	235.5	1123.7	1725.3
4	100	27	460	6440	0.400	634.8	253.9	1204.6	1851.8
3	100	27	460	6900	0.400	680.8	272.3	1285.4	1978.2
2	100	27	460	7360	0.400	726.8	290.7	1366.3	2104.7



# The Odyssey Condominium

Aaron Snyder  
Structural Option

			Column B/7.5 Exterior w/o Cantilever + Ext. Wall Col Exten.				$K_{LL} = 4$		
Level/Column:	Live (PSF)	Dead (PSF)	Area (ft <sup>2</sup> )	$A_T$ (ft <sup>2</sup> )	Reduction	Live Load (kip)	Reducd LL (kip)	Dead Load (kip)	Factrd Load (kip)
Roof	0	*conc	0	0	1.00	0.0	0.0	27.2	32.6
16	30	50	200	200	1.000	6.0	6.0	78.5	103.8
15	100	27	200	400	0.625	26.0	26.0	124.8	191.4
14	100	27	200	600	0.556	46.0	25.6	170.4	245.5
13	100	27	200	800	0.515	66.0	34.0	216.0	313.6
12	100	27	200	1000	0.487	86.0	41.9	261.6	381.0
11	100	27	200	1200	0.467	106.0	49.4	307.2	447.8
10	100	27	200	1400	0.450	126.0	56.8	352.8	514.2
9	100	27	200	1600	0.438	146.0	63.9	398.4	580.3
8	100	27	200	1800	0.427	166.0	70.8	444.0	646.1
7	100	27	200	2000	0.418	186.0	77.7	489.6	711.8
6	100	27	200	2200	0.410	206.0	84.4	535.2	777.3
5	100	27	200	2400	0.403	226.0	91.1	580.8	842.7
4	100	27	200	2600	0.400	246.0	98.4	626.3	909.1
3	100	27	200	2800	0.400	266.0	106.4	671.9	976.6
2	100	27	200	3000	0.400	286.0	114.4	717.5	1044.1

			Round Column B/6.3 Corner w/ Cantilever + Ext. Wall				$K_{LL} = 2$		
Level/Column:	Live (PSF)	Dead (PSF)	Area (ft <sup>2</sup> )	$A_T$ (ft <sup>2</sup> )	Reduction	Live Load (kip)	Reducd LL (kip)	Dead Load (kip)	Factrd Load (kip)
Roof	0	*conc	0	0	1.000	0.0	0.0	26.7	32.0
16	30	50	270	270	1.000	8.1	8.1	82.5	112.0
15	100	27	270	540	0.706	35.1	24.8	132.9	199.1
14	100	27	270	810	0.623	62.1	38.7	183.3	281.8
13	100	27	270	1080	0.573	89.1	51.0	233.6	362.0
12	100	27	270	1350	0.539	116.1	62.5	284.0	440.9
11	100	27	270	1620	0.514	143.1	73.5	334.4	518.8
10	100	27	270	1890	0.494	170.1	84.0	384.7	596.1
9	100	27	270	2160	0.478	197.1	94.3	435.1	673.0
8	100	27	270	2430	0.465	224.1	104.2	485.5	749.4
7	100	27	270	2700	0.454	251.1	114.0	535.9	825.5
6	100	27	270	2970	0.445	278.1	123.7	586.2	901.3
5	100	27	270	3240	0.436	305.1	133.1	636.6	976.9
4	100	27	270	3510	0.429	332.1	142.5	687.0	1052.4
3	100	27	270	3780	0.423	359.1	151.7	737.4	1127.6
2	100	27	270	4050	0.417	386.1	160.9	787.0	1201.8

			Shearwall Column C/7.5 w/ Shearwall				$K_{LL} = 4$		
Level/Column:	Live (PSF)	Dead (PSF)	Area (ft <sup>2</sup> )	$A_T$ (ft <sup>2</sup> )	Reduction	Live Load (kip)	Reducd LL (kip)	Dead Load (kip)	Factrd Load (kip)
Roof	30	50	190	190	1.000	0.0	0.0	26.7	32.0
16	150	150	190	380	1.000	5.7	5.7	67.5	90.1
15	100	27	190	570	0.564	24.7	13.9	104.7	148.0
14	100	27	190	760	0.522	43.7	22.8	141.9	206.8
13	100	27	190	950	0.493	62.7	30.9	179.1	264.5
12	100	27	190	1140	0.472	81.7	38.6	216.4	321.3
11	100	27	190	1330	0.456	100.7	45.9	253.6	377.7
10	100	27	190	1520	0.442	119.7	53.0	290.8	433.7
9	100	27	190	1710	0.431	138.7	59.8	328.0	489.3
8	100	27	190	1900	0.422	157.7	66.6	365.2	544.8
7	100	27	190	2090	0.414	176.7	73.2	402.4	600.0
6	100	27	190	2280	0.407	195.7	79.7	439.6	655.0
5	100	27	190	2470	0.401	214.7	86.1	476.9	709.9
4	100	27	190	2660	0.400	233.7	93.5	514.1	766.4
3	100	27	190	2850	0.400	252.7	101.1	551.3	823.3
2	100	27	190	3040	0.400	271.7	108.7	587.7	879.2



# The Odyssey Condominium

Aaron Snyder  
Structural Option

## Appendix D Deflections

Shear Wall / Slab Frame

Level	Point	Load	UX	UY	Utotal	Level Ht.	Ulimit	CHECK
15	108	EQXUSER	1.3482	0.0392	1.35	139.5	2.79	OK
15	108	EQYUSER	-0.4643	2.7513	2.79	139.5	2.79	OK
14	108	EQXUSER	1.2049	0.0462	1.21	128.58	2.57	OK
14	108	EQYUSER	-0.4379	2.5264	2.56	128.58	2.57	OK
13	108	EQXUSER	1.0822	0.049	1.08	119	2.38	OK
13	108	EQYUSER	-0.4064	2.3305	2.37	119	2.38	OK
12	108	EQXUSER	0.9599	0.0504	0.96	109.413	2.19	OK
12	108	EQYUSER	-0.3725	2.0986	2.13	109.413	2.19	OK
11	108	EQXUSER	0.8385	0.0508	0.84	99.8297	2.00	OK
11	108	EQYUSER	-0.3364	1.8621	1.89	99.8297	2.00	OK
10	108	EQXUSER	0.7191	0.05	0.72	90.2464	1.80	OK
10	108	EQYUSER	-0.2985	1.6228	1.65	90.2464	1.80	OK
9	108	EQXUSER	0.6031	0.0481	0.61	80.66	1.61	OK
9	108	EQYUSER	-0.2592	1.3836	1.41	80.66	1.61	OK
8	108	EQXUSER	0.4921	0.0451	0.49	71.08	1.42	OK
8	108	EQYUSER	-0.2191	1.1479	1.17	71.08	1.42	OK
7	108	EQXUSER	0.3879	0.0409	0.39	61.5	1.23	OK
7	108	EQYUSER	-0.1791	0.9199	0.94	61.5	1.23	OK
6	108	EQXUSER	0.2925	0.0355	0.29	51.9132	1.04	OK
6	108	EQYUSER	-0.1401	0.7047	0.72	51.9132	1.04	OK
5	108	EQXUSER	0.2076	0.0291	0.21	42.33	0.85	OK
5	108	EQYUSER	-0.1031	0.5074	0.52	42.33	0.85	OK
4	108	EQXUSER	0.1348	0.022	0.14	32.7466	0.65	OK
4	108	EQYUSER	-0.0695	0.333	0.34	32.7466	0.65	OK
3	108	EQXUSER	0.0754	0.0147	0.08	23.163	0.46	OK
3	108	EQYUSER	-0.0404	0.1869	0.19	23.163	0.46	OK
2	108	EQXUSER	0.0319	0.0076	0.03	13.58	0.27	OK
2	108	EQYUSER	-0.0179	0.0776	0.08	13.58	0.27	OK

Shear Wall / Slab Frame

Level	Point	Load	UX	UY	Utotal	Level Ht.	Ulimit	CHECK
ROOF	98	EQXUSER	1.5746	0.0423	1.58	166.74	3.33	OK
ROOF	98	EQYUSER	0.3431	2.9748	2.99	166.74	3.33	OK
16	98	EQXUSER	1.375	0.0633	1.38	150.74	3.01	OK
16	98	EQYUSER	0.3396	2.6692	2.69	150.74	3.01	OK
15	99	EQXUSER	1.2692	0.1422	1.28	139.5	2.79	OK
15	99	EQYUSER	0.3316	1.7628	1.79	139.5	2.79	OK
14	99	EQXUSER	1.1427	0.1272	1.15	128.58	2.57	OK
14	99	EQYUSER	0.3127	1.577	1.61	128.58	2.57	OK
13	99	EQXUSER	1.0315	0.1152	1.04	119	2.38	OK
13	99	EQYUSER	0.2943	1.4162	1.45	119	2.38	OK
12	99	EQXUSER	0.9196	0.1031	0.93	109.413	2.19	OK
12	99	EQYUSER	0.2736	1.2556	1.29	109.413	2.19	OK
11	99	EQXUSER	0.808	0.0906	0.81	99.8297	2.00	OK
11	99	EQYUSER	0.2506	1.0961	1.12	99.8297	2.00	OK
10	99	EQXUSER	0.6977	0.0779	0.70	90.2464	1.80	OK
10	99	EQYUSER	0.2256	0.939	0.97	90.2464	1.80	OK
9	99	EQXUSER	0.59	0.0652	0.59	80.66	1.61	OK
9	99	EQYUSER	0.1988	0.786	0.81	80.66	1.61	OK
8	99	EQXUSER	0.4862	0.0528	0.49	71.08	1.42	OK
8	99	EQYUSER	0.1706	0.6393	0.66	71.08	1.42	OK
7	99	EQXUSER	0.388	0.0408	0.39	61.5	1.23	OK
7	99	EQYUSER	0.1418	0.5012	0.52	61.5	1.23	OK
6	99	EQXUSER	0.2968	0.0298	0.30	51.9132	1.04	OK
6	99	EQYUSER	0.1128	0.3747	0.39	51.9132	1.04	OK
5	99	EQXUSER	0.2145	0.0201	0.22	42.33	0.85	OK
5	99	EQYUSER	0.0847	0.2622	0.28	42.33	0.85	OK
4	99	EQXUSER	0.1425	0.0119	0.14	32.7466	0.65	OK
4	99	EQYUSER	0.0584	0.1661	0.18	32.7466	0.65	OK
3	99	EQXUSER	0.0824	0.0055	0.08	23.163	0.46	OK
3	99	EQYUSER	0.0349	0.0885	0.10	23.163	0.46	OK
2	99	EQXUSER	0.0367	0.0014	0.04	13.58	0.27	OK
2	99	EQYUSER	0.016	0.0333	0.04	13.58	0.27	OK





# The Odyssey Condominium

Aaron Snyder  
Structural Option

## Story Drift

Shear Wall / Slab Frame - Story Drift

Level	Item	Load	Point	DriftX	DriftY	Level Ht.	hx.	Drift	ΔAllow	CHECK
ROOF	Max Drift X	EQXUSER	102	0.0011		166.74	16.0	0.21	3.84	OK
ROOF	Max Drift Y	EQYUSER	102		0.0016	166.74	16.0	0.30	3.84	OK
16	Max Drift X	EQXUSER	96	0.0011		150.74	11.2	0.15	2.70	OK
16	Max Drift Y	EQYUSER	74		0.0017	150.74	11.2	0.23	2.70	OK
15	Max Drift X	EQXUSER	108	0.0011		139.5	10.9	0.14	2.62	OK
15	Max Drift Y	EQYUSER	108		0.0019	139.5	10.9	0.24	2.62	OK
14	Max Drift X	EQXUSER	108	0.0011		128.58	9.6	0.12	2.30	OK
14	Max Drift Y	EQYUSER	108		0.002	128.58	9.6	0.23	2.30	OK
13	Max Drift X	EQXUSER	108	0.0011		119	9.6	0.12	2.30	OK
13	Max Drift Y	EQYUSER	108		0.002	119	9.6	0.23	2.30	OK
12	Max Drift X	EQXUSER	108	0.0011		109.413	9.6	0.12	2.30	OK
12	Max Drift Y	EQYUSER	108		0.0021	109.413	9.6	0.24	2.30	OK
11	Max Drift X	EQXUSER	108	0.001		99.8297	9.6	0.12	2.30	OK
11	Max Drift Y	EQYUSER	108		0.0021	99.8297	9.6	0.24	2.30	OK
10	Max Drift X	EQXUSER	108	0.001		90.2464	9.6	0.12	2.30	OK
10	Max Drift Y	EQYUSER	108		0.0021	90.2464	9.6	0.24	2.30	OK
9	Max Drift X	EQXUSER	108	0.001		80.66	9.6	0.11	2.30	OK
9	Max Drift Y	EQYUSER	108		0.002	80.66	9.6	0.24	2.30	OK
8	Max Drift X	EQXUSER	108	0.0009		71.08	9.6	0.10	2.30	OK
8	Max Drift Y	EQYUSER	108		0.002	71.08	9.6	0.23	2.30	OK
7	Max Drift X	EQXUSER	108	0.0008		61.5	9.6	0.10	2.30	OK
7	Max Drift Y	EQYUSER	108		0.0019	61.5	9.6	0.22	2.30	OK
6	Max Drift X	EQXUSER	108	0.0007		51.9132	9.6	0.08	2.30	OK
6	Max Drift Y	EQYUSER	108		0.0017	51.9132	9.6	0.20	2.30	OK
5	Max Drift X	EQXUSER	108	0.0006		42.33	9.6	0.07	2.30	OK
5	Max Drift Y	EQYUSER	108		0.0015	42.33	9.6	0.17	2.30	OK
4	Max Drift X	EQXUSER	121	0.0005		32.7466	9.6	0.06	2.30	OK
4	Max Drift Y	EQYUSER	108		0.0013	32.7466	9.6	0.15	2.30	OK
3	Max Drift X	EQXUSER	121	0.0004		23.163	9.6	0.05	2.30	OK
3	Max Drift Y	EQYUSER	108		0.001	23.163	9.6	0.11	2.30	OK
2	Max Drift X	EQXUSER	121	0.0002		13.58	13.6	0.04	3.26	OK
2	Max Drift Y	EQYUSER	108		0.0005	13.58	13.6	0.08	0.33	OK