



*The Pennsylvania State University  
Spring 2006 AE Senior Thesis*

---

*Advisor: Dr. Michael Horman*

# Johns Hopkins University Charles Commons

*Baltimore, Maryland*

**Bryan A. Quinn**  
*Construction Management*



## PROJECT TEAM

Owner: Struever Bros. Eccles & Rouse & Johns Hopkins University  
Developer: Capstone Development Inc.  
Architect: Design Collective  
Contractor: Struever Bros. Eccles & Rouse  
Structural Engineer: Hope-Furrer Associates  
MEP Engineer: Koehler, Burdette, Murphy & Associates

# JOHNS HOPKINS UNIVERSITY-CHARLES COMMONS BALTIMORE, MARYLAND

BRYAN QUINN, CONSTRUCTION MANAGEMENT OPTION  
[WWW.ARCH.PSU.EDU/THESIS/EPOR TFOLIO/CURRENT/POR TFOLIOS/BAQ104](http://WWW.ARCH.PSU.EDU/THESIS/EPOR TFOLIO/CURRENT/POR TFOLIOS/BAQ104)

- 2 Buildings: 12-story Charles & 10-story St. Paul
- Post-tensioned floor slab with mild reinforcement that spans a maximum of 33'
- Reinforced concrete drilled caissons up to 7' diameter
- Reinforced concrete columns up to 8000 psi

## STRUCTURAL

- Estimated Cost: \$63 million
- Contract: CM@Risk with a GMP
- Start of Construction: November 16, 2004
- Substantial Completion: July 26, 2005
- Location: Block of 33rd Street between St. Paul and Charles Streets

## CONSTRUCTION

- 8 AHUs using water from (2) 600-ton water-cooled chillers
- 10 split-system A/C units used in the IST and Elevator rooms
- 1 cooling tower and 2 gas-fired boilers on the roof of St. Paul building.
- 2 hot water recirculators, 2 hot water generators, 5 hot water heaters

## MECHANICAL

- 2 Outdoor Transformers
- (3) 480Y/277V, 3-phase, 4-wire switch-gears rated up to 3000A
- Luminaires: recessed parabolic fluorescents, pendant fluorescents, metal halide track lighting, indoor/outdoor neon lighting, and metal halide dome fixtures

## ELECTRICAL





# Charles Commons

## Table of Contents

Executive Summary.....7  
 Acknowledgements.....8  
 Building Information.....9

### Construction Management Depth

Assessment of Design-Build-Operate-Maintain and Build-Operate-Transfer as Delivery Methods in Building Construction

Background.....12  
 Problem Identification.....12  
 Research Goals.....13  
 Project Delivery Definitions.....13  
 Design-Build Hybrids.....14  
 Delivery Advantages/Disadvantages.....15

**Market Analysis.....16**

**Civil Infrastructure Case Studies.....21**

**Building Case Studies.....43**  
 Clackamas County Public Services Building.....44  
 UW Research & Technology Building.....48  
 Interview with CollinsWoerman.....50

**JHUCC - Analysis of Alternative Delivery Methods.....52**  
 Existing Project Delivery Method.....52  
 Analysis Criteria.....52  
 Interview with JHU Facilities Management.....53  
 Schedule Reduction Comparison.....56  
 Conclusion.....57  
 Market Outlook.....59

**Owner's Guide to DBOM/BOT.....61**  
 Background.....61  
 Existing Guide Criteria.....61  
 Guide Criteria Amendments.....63  
 Integrated Project Delivery System Selection Model.....65  
 IPDSS Conclusion.....69  
 References.....70



# Charles

# Commons

## Structural Breadth

Redesign of Partially Post-Tensioned Structural Slabs with Alternative Systems

**Partially Post-Tensioned Structural Slabs.....72**

- Charles Building.....72
- St. Paul Building.....73
- Load Calculations.....77
- Existing Structural Floor System.....77
- Study of Alternate Floor Systems.....79

**Alternate I: Flat-plate reinforced concrete slab.....79**

**Alternate II: One-way reinforced concrete beams.....89**

- Adjusting the Column Layout.....89
- Architectural Adjustments.....90

**Alternate III: Precast planks on cast-in-place beams.....99**

**Comparison of Structural Systems.....108**

- Constructability Review Summary*.....108
- Schedule Reduction*.....109
- Value Engineering*.....111
- Structural Conclusions*.....114

## Mechanical Breadth

MEP Coordination/Ductwork Rerouting for Alternative Structural Systems

- Background.....116
- Analysis Goals.....117
- Spatial Requirements.....119

**Two-Dimensional MEP Coordination Analysis.....122**

- Ductwork Rerouting Issues.....123

**Mechanical Ductwork Sizing.....129**

- Duct Sizing Calculations.....131
- Value Engineering*.....133

**Three-Dimensional MEP Coordination Analysis.....135**

- 3-D Mechanical Rooms.....137

**Four-Dimensional MEP Coordination Analysis.....139**





# Charles

# Commons

Constructability Review.....I40  
 MEP Coordination Analysis Comparisons.....I43  
 Mechanical Conclusion.....I44

**Recommendations.....I46**



# Charles

# Commons

## Table of Figures

(Figures are numbered according to their respective page numbers)

### Construction Management Depth

Figure 1: Cost Benefit Curve

Figure 3.1: Delivery Process Diagram

Figure 3.2: Advantages and Disadvantages of Delivery Methods

Figure 4: Worldwide Transportation Projects by Contract Type

Figure 7: U.S. Transportation Infrastructure Projects by Contract Type

Figure 8: Commuter Rail Projects Using DBOM in U.S.

Figure 10: Civil Infrastructure Projects Using DBOM/BOT in U.S.

Figure 13: SMP DBOM and O&M Variations Comparison

Figure 18: JFK Airtrain Owner and Contractor Goals

Figure 45.1: Charles Commons Schedule by Delivery Method

Figure 45.2: Charles Commons Delivery Method Comparisons

Figure 49: Market Futures for DBOM/BOT

Figure 55: Criteria Comparison for IPDSS Model

Figure 56: IPDSS 1.1 for Public Projects

Figure 57: IPDSS 1.2 for Private Projects

### Structural Breadth

Figure 2: Charles and St. Paul building elevations

Figure 3: Second Floor Plan

Figure 4: Third Floor Plan

Figure 5: Fourth Floor Plan

Figure 12: Typ. Flat Plate Section @ Column/Beam

Figure 13: Typ. Flat Plate Section @ Interior Column

Figure 14: E-TABS model of flat plate system

Figure 18: Existing Column Layout vs. Adjusted Column Layout

Figure 19.1: Second Floor, at elevator #9

Figure 19.2: Second Floor, at the loading dock

Figure 20: Third Floor, at the dining servery

Figure 23: Typ. One-way beams @ Column/Beam

Figure 24: Typ. One-way beams @ Interior Column

Figure 25: E-TABS model of one-way beam system

Figure 27: E-TABS screenshot of deflections

Figure 30: Typ. Precast plank @ Column/Beam

Figure 31: Typ. Precast plank @ Interior Column

Figure 32: Nitterhouse Specification for 8"x4' Spandek

Figure 33: E-TABS model of precast plank system

Figure 35: E-TABS screenshot of deflections

Charles



Commons

*Figure 38: Schedule Comparison of Alternative Structural Systems*

*Figure 40: Cost Breakdown of Alternative Structural Systems*

*Figure 42: Cost Comparison of Alternative Structural Systems*

## **Mechanical Breadth**

*Figure 2: MEP Coordination Process at Charles Commons*

*Figure 4: Plenum Height Comparisons*

*Figure 6.1: Typical Air-Handling Unit*

*Figure 6.2: Typical Fan-Coil Unit*

*Figure 8: E1, Exhaust from 1<sup>st</sup> floor*

*Figure 9: EB2, Return from 2<sup>nd</sup> floor bookstore*

*Figure 10: EB2.1, Main branch return from 2<sup>nd</sup> floor bookstore*

*Figure 11: S3, 3<sup>rd</sup> floor conference corridor supply*

*Figure 12: E3.1, Hood exhaust from 3<sup>rd</sup> floor kitchen*

*Figure 13: E3.2, Bathroom/office exhaust from 3<sup>rd</sup> floor kitchen*

*Figure 14: Marinsoft Duct Calculator screenshot*

*Figure 18: MEP Value Engineering*

*Figure 22: Second Floor Mechanical Room, AHU 4 & 5*

*Figure 23: Third Floor Mechanical Rooms, AHU 6 & 7*





*Charles*

*Commons*

*Table of Appendices*

**Appendix A – CM Research**

Background of UW Research & Technology Building

**Appendix B – Structural Breadth**

*E-TABS Graphic Results*

Flat-Plate Strength-Required Reinforcement

Flat-Plate Unbalanced Moment Diagrams

Flat-Plate Axial Forces

One-Way Beams Strength-Required Reinforcement

One-Way Beams Axial Forces

Precast Plank Strength-Required Reinforcement

Precast Plank Axial Forces

4-D Screenshots of Structural Sequencing

**Appendix C – Mechanical Breadth**

4-D Sequencing Schedule

4-D Screenshots of MEP Sequencing

*Charles*



*Commons*

## *Executive Summary*

Currently, the latest state-of-the-art dormitory for Johns Hopkins University (JHU) is going to be late for the Fall 2006 grand opening. Two years ago, Charles Commons was a schematic sketch of a facility that would house 600+ students as part of JHU's five-year plan. Since Spring 2005, Charles Commons is site of the most grueling 16-hour, 7-day shiftwork in Baltimore due to the superstructure construction delays and MEP coordination issues associated with the first three floors of St. Paul Building. This report details the preventative medicines for these issues and aims to arm owners with a better roadmap to their own project's future.

In order to investigate these challenges of Charles Commons, three analyses were prepared:

- Assessment of Design-Build-Operate-Maintain and Build-Operate-Transfer As Delivery Methods in Building Construction
- Redesign of Post-Tensioned Slabs with Alternative Systems
- MEP Coordination/Duct Rerouting for the Alternative Structural Systems

These analyses were initiated to take a multi-faceted approach at the design, coordination, and construction processes of Charles Commons in order to pin-point errors relating to the decision-making of the owner, engineer, and construction manager. It is my belief that with more-informed decision-making, the project team could have averted the debilitating delays and overruns associated with the dining hall, bookstore, and lobby spaces in the St. Paul building.



# Charles

# Commons

## *Acknowledgements*

*To everyone who has helped me through the course of this project, who have made time to shed light on topics I could not have possibly comprehended alone, and those who were great company during those long nights in thesis lab... I can't thank you enough!*

### Fellow AE students

*Frank Burke*

*Lourdes Diaz*

*Jess Lucas*

*Sean Howard*

*Shawn Jones*

*among many others...*

### AE Thesis Advisors

*Dr. Michael Horman*

*Dr. Kevin Parfitt*

*Dr. Moses Ling*

*Pete Dahl*

### Fellow SBER staff

*Ally Diaz*

*Dominic Wiker*

*Scott Stewart, Hope-Furrer*

*Mike DiProspero, JHU Office of Facilities Management*

*John Whitlow & Jon Szczeniak, CollinsWoerman*

*Dedicated to:*

*Mom & Dad*

*Last but not least, I owe all of my successes to you, you that have worked so hard to give me this opportunity. When times turn rough, my family is always there to keep my head in the game... I am eternally grateful.*





# Charles

# Commons

## Building Information

### General Information

Charles Commons is a new dormitory complex for JHU which is located at the corner of 33<sup>rd</sup> Street and St. Paul Avenue in Baltimore, Maryland. The dormitory is centrally located on campus because its full-service dining hall and bookstore will be used by the whole of the student body. The new dormitories feature a full-service dining hall, a bookstore, and a credit union. In addition, Charles Commons includes various offices, faculty apartments, computer rooms, fitness centers, and loading docks. The use groups are characterized as A-2 and A-3 Assembly, Mercantile, R-2 Residential, and Business.

The Charles building is 12 stories tall and 110,000 sf. The St. Paul building is 10 stories and 203,000 sf. Overall, Charles Commons provides 620 beds and 210 rooms for Johns Hopkins University students. The Charles building is 12 stories and the St. Paul building is 10 stories.

### Project Team



### Construction Information

The project started foundations on November 16, 2004 (at the conclusion of demolition). The projected date of substantial completion is June 8, 2006, wherein final completion is August 8, 2006. The University wants the building to be complete in time for the start of the fall session of classes in 2006.

The project is budgeted to cost \$57,996,484 in direct costs, \$3,302,516 (5.24%) in general conditions, and \$1,701,000 in fee (2.70%). The Design-Bid-Build, GMP contract total is \$63,000,000.

# Charles



# Commons



## Architecture

Two buildings at ten and twelve stories tower over the campus streetscape of Johns Hopkins University. The ten story St. Paul building is U-shaped after the third floor to allow for a courtyard view for the housed students. The Charles building has a rectangular footprint that is continuous on all twelve floors. Both buildings have a variety of room layouts including housing units that have their own kitchen, living, and bathroom amenities.

In addition to student housing, Charles Commons features the following for their students: retail, lounges, computer labs, fitness centers, community kitchens, music rooms, a bookstore, and a full-service dining commons. In order to operate the two buildings, Johns Hopkins will also utilize the following: loading docks, laundry amenities, security offices, mail distribution center, housing and counseling offices, and faculty apartments. The exterior of both buildings are broken up into an architectural precast concrete façade for the first two floors and brick façade for the floors above. The roof for each building is flat and highlighted by a precast cornice.



The main access for both buildings are along 33<sup>rd</sup> Street and secondary entrances can be found on St. Paul and Charles Streets. The loading area for St. Paul's dining commons and bookstore is found in an alley to the North. Lovegrove Street runs between St. Paul and Charles buildings and serves as access to the North alley loading area and utility access.





*Charles*

*Commons*

**Construction Management Depth:  
Assessment of Design-Build-Operate-Maintain  
and Build-Operate-Transfer As Delivery Methods  
in Building Construction**







Charles

Commons

### Background

The structuring and hiring of a project team, called a project delivery method, is critical to the success of any project. The choice an owner makes at this junction can affect the project's cost, schedule, and quality. In addition, each delivery method has its own benefits and side effects the team must deal with for the duration of the project. As shown in the following diagram taken from B.C. Paulson shows the biggest impact on cost is made from the concept development and contract stages.

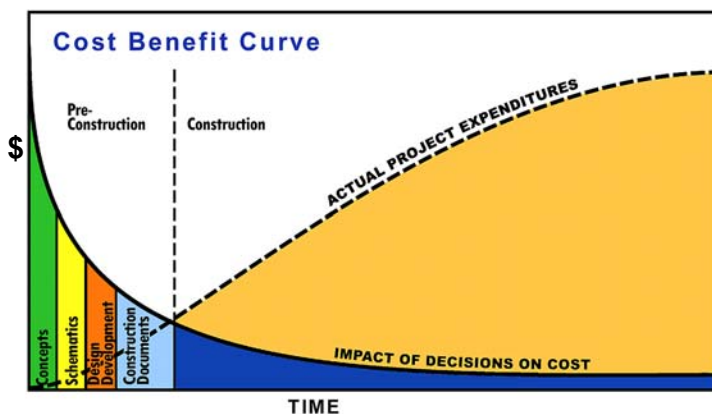

Figure 1: Cost Benefit Curve from B.C. Paulson in "Designing to Reduce Construction Costs." Decisions made at the Concept stage in pre-construction make the largest impact on the overall project cost.

The process of choosing a project delivery method can be difficult for many owners. Unlike the Miranda Rights that are given to every criminal, there is no definitive model that owners could use to choose a delivery method for their specific project. The best model in circulation today is Sanvido and Konchar's Project Delivery System Selection (PDSS) which identifies four project deliveries to choose from: Design-Bid-Build (Traditional), Design-Build, CM Agency, and CM@Risk. In addition, there are six variables in which to choose from: project characteristics, time, owner experience, team experience, quality, and cost. Although this document is quite useful for most owners, it does not reflect the latest advancements in project deliveries, the Design-Build hybrids. In addition, the Design-Build hybrids are difficult to integrate into the PDSS using the existing six variables since the hybrids are quite complicated.

### Problem Identification

Currently, the latest state-of-the-art dormitory for Johns Hopkins University (JHU) is going to be late for the Fall '06 grand opening. Two years ago, Charles Commons was a schematic sketch of a facility that would house 600+ students as part of JHU's five-year plan. A fateful program change in Spring '05 permitting a dining commons to be placed on the third floor of the St. Paul building changed the complexion of the project. This addition and steel market fluctuations caused a huge

# Charles



# Commons

increase in the cost of Charles Commons. The cost-cutting process that followed caused anxiety amongst the project team.

Very little could have been done to prevent JHU's program change. However, a different delivery method could have prepared the project team better for this change and accelerate the design processes. The current project delivery system used is CM@Risk, which is a source of much tension when the steel market fluctuations occurred in early 2005. Using the PDSS model, JHU's only choice for a project delivery method is a CM Agency, which could not have allowed the project team to maintain budget and schedule.

Design-Build has been driving alternative delivery method for a few decades and has just recently begun branching into other hybrid delivery methods. In addition to design and construction, Design-Builders are taking on the risks of the Operations and Maintenance (O&M) and the financing of the project. Thus, the Design-Build hybrids Design-Build-Operate-Maintain (DBOM) and Build-Operate-Transfer (BOT) were born. Could the Charles Commons project team benefit from DBOM or BOT?

### *Research Goals*

- *Analyze issues in case studies in which DBOM/BOT have proved effective and make market comparisons and outlook for future.*
- *Evaluate the advantages/disadvantages from using DBOM/BOT delivery methods at Charles Commons.*
- *Generate an Owner's Guide to DBOM/BOT for use in the Building Construction Industry.*

### *Project Delivery Definitions*

**Design-Bid-Build (DBB)** is the traditional method of project delivery since the beginning of the Industrial Age. DBB is characterized by the owner having numerous separate contracts with the design team and the construction team. The phasing of the work is sequential: design phase, procurement phase, and construction phase. Typically, the contract is awarded through a low price bid in a lump sum amount. After completion of the project, the owner is responsible for operations and maintenance (O&M).

**Construction Management Agency (CM Agent)** involves the hiring of a construction manager who then serves to broker the hiring of subcontractors under direct contract with the owner. The CM Agent is frequently a fee-based agreement and this approach can allow for fast-tracking since constructability issues can be



# Charles

# Commons

addressed during design. However, the CM Agent is not responsible for O&M and many of the risks associated with the project.

**Construction Manager at Risk (CM@Risk)** allows owner to contract one construction manager, of whom manages the design professionals and subcontractors at a Guaranteed Maximum Price (GMP) or lump sum. The CM@Risk assumes all of the risk that an owner would control during a CM Agent delivery. This agreement can bring about claims between the design professionals and construction managers. Again, O&M is not included.

**Design-Build (DB)** involves the owner hiring one entity, a design-builder, to provide both design and construction services. This method requires a clearly defined scope of work and a cost commitment is made early in the design process. Typically, design-build has a fast schedule, best cost control, and least amount of claims. Additional strengths of DB include reduced owner's risks, establishing a fixed price early in the process and this method establishes a fixed schedule. However, there may be little owner control in design and value engineering can potentially impact quality if not properly managed.

### *Design-Build Hybrids*

**Design-Build-Operate-Maintain (DBOM)** is a Design-Build delivery method in which the owner selects a consortium (project team) that will complete the design, construction, maintenance and a period of operational parameters under one agreement. Upon termination of the operational period, the owner is then responsible for operations and maintenance of the project. Since some experienced owners may or may not have physical plant workers, variations such as **Design-Build-Operate (DBO)** have been used.

**Build-Operate-Transfer (BOT)** is a project delivery in which the financial services of a bank or developer are used by the project team. The contracted project team acquires ownership of the project under the end of a stipulated time period. A similar method, **Design-Build-Finance-Operate (DBFO)** does not employ the services to transfer ownership, but to defray the expenses of construction into a yearly operations budget. Many Public-Private-Partnerships (PPP's) participate similarly by forming a concession. A **Concession** is a contract arrangement which grants the contract team full responsibility to finance, build, operate, and/or maintain the facility as a franchisee for a specified period of time, whereby the private sector team takes most of the project and financial risks and potential rewards for the term of the concession contract.

The following process chart displays the roles of DBB, DBOM, and DBFO in the delivery of transportation infrastructure as reported by Daniel L. Dornan in a report to the Federal Highway Administration titled "Synthesis of Public-Private Partnership Projects For Roads, Bridges & Tunnels From Around the World 1985-2004."



# Charles

# Commons

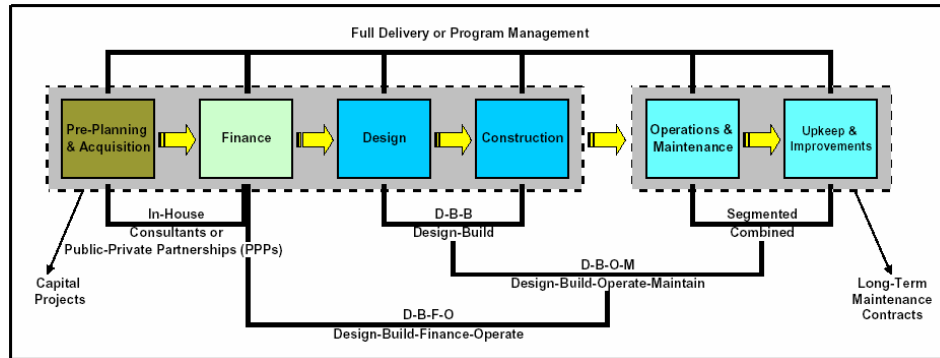

Figure 3.1: Delivery Process Diagram from Daniel L. Dornan in “Synthesis of Public-Private Partnership Projects For Roads, Bridges & Tunnels From Around the World 1985-2004.” This distinguishes the roles of DBB, DBOM, and DBFO. It also shows the importance of PPP’s to the development of hybrid design-builds.

Figure 3.2: Advantages and Disadvantages of Delivery Methods

Delivery	Advantages	Disadvantages
DBB	Design defined prior to bidding Max Competition Least initial bidding time	Minimal input from contractors/operations Longer schedules Adversarial relationships Owner responsible to Contractor for design errors Many change orders Many interfaces High risk Need for owner’s decisions Lack of innovation Least value
CM@Risk	Less Risk Good for owners with insufficient staff	Conflict of interest Many change orders Many interfaces Need for owner’s decisions
CM Agency	Less change orders Good for owners with insufficient staff	Many interfaces Need for owner’s decisions Risky for owners No CM responsibility to outcome of project
DB	Contractor input early Good for all types of owners Increased quality and shorter durations Single point liability Reduced change orders Less interfaces Less risk Pre-project planning cost savings	Minimal input from operators Owner loses design control Requires team experience Fewer bidders Lengthy initial bidding Financial, O&M, and political risk remains the owner’s





# Charles

# Commons

DBOM	<ul style="list-style-type: none"> <li>Contractor and O&amp;M input early</li> <li>Increased quality and shorter durations</li> <li>Increased emphasis on long-term operations costs</li> <li>Owner only responsible for political risk</li> <li>Eliminate gaps in responsibility/coordination</li> <li>Company guarantees instead of bonds</li> <li>Least change orders</li> <li>Less interfaces</li> <li>Innovative</li> <li>Reduces risk of unnoticed items</li> </ul>	<ul style="list-style-type: none"> <li>Owner loses design &amp; operations control</li> <li>Requires additional planning from owner</li> <li>Team needs experience with DB</li> <li>Limited "checks and balances"</li> <li>Almost no bidders to choose from</li> <li>Long initial bidding</li> <li>High initial costs</li> <li>Not for inexperienced owners</li> <li>Politics may change during contract</li> </ul>
DBFO	<ul style="list-style-type: none"> <li>Less interfaces</li> <li>Better net present value</li> <li>Risk elimination</li> <li>Innovative</li> <li>Reduces risk of unnoticed items</li> <li>Lower cost of capital</li> <li>Company guarantees instead of bonds</li> </ul>	<ul style="list-style-type: none"> <li>Almost no bidders to select from</li> <li>Longest initial bidding process</li> <li>Politics may change during contract</li> <li>High initial costs</li> <li>Not for inexperienced owners</li> <li>Limited "checks and balances"</li> </ul>
BOT	<ul style="list-style-type: none"> <li>Company guarantees instead of bonds</li> <li>One interface</li> <li>Risk elimination</li> <li>Reduces risk of unnoticed items</li> <li>Lower cost of capital/better net present value</li> <li>Innovative</li> </ul>	<ul style="list-style-type: none"> <li>Almost no bidders to select from</li> <li>Longest initial bidding process</li> <li>Politics may change during contract</li> <li>High initial costs</li> <li>Not for inexperienced owners</li> <li>Limited "checks and balances"</li> </ul>

*Market Analysis*

*Highway Infrastructure Market*

Currently, the Design-Build hybrids are not widely used, but their successes have been scrutinized for years in this market. Few design-builders and owners have experience with DBOM/BOT and even fewer consider the option for buildings. However, the highway infrastructure market has recently seen an explosion of projects employing these untested methods. As shown in the following table compiled by Daniel L. Dornan in the aforementioned report to the Federal Highway Administration shows how far the hybrid design-builds have come worldwide.

Contract Type	Number	Percent	\$ Billion	Percent	\$/Project
<b>Concession</b>	<b>245</b>	<b>41%</b>	<b>\$124.2</b>	<b>39%</b>	<b>\$0.507</b>
DBFO	61	10%	\$31.5	10%	\$0.516
DBOM	49	8%	\$35.7	11%	\$0.728
<b>BOT/BTO</b>	<b>183</b>	<b>31%</b>	<b>\$84.4</b>	<b>26%</b>	<b>\$0.461</b>
BOO	8	1%	\$1.9	1%	\$0.239
DB	41	7%	\$43.2	13%	\$1.054
Mgt Contract	12	2%	\$1.5	0%	\$0.127
Total	599	100%	\$322.4	100%	\$0.538

Figure 4: Worldwide Transportation Infrastructure Projects by Contract Type from Daniel L. Dornan in "Synthesis of Public-Private Partnership Projects For Roads, Bridges & Tunnels From Around the World 1985-2004." This shows that although hybrid design-builds have not become prevalent in the building industry, these methods have become more prevalent than Design-Build projects. Concession and BOT projects are most

## Charles



## Commons

frequently chosen worldwide where public entities have much less investment capital for infrastructure than private entities.

On the following page, Mr. Dornan continues to breakdown each of the types of transportation infrastructure in the United States by delivery method. Although Design-Build still reigns supreme in the number of domestic transportation projects, the contract quantities for Design-Build are far behind those planned and completed using DBOM and Concession. The following passage is one conclusion Mr. Dornan uses to explain this growth of design-build hybrids:

<sup>3</sup> On July 29, 2005 Congress passed the “Safe, Accountable, Flexible, Efficient Transportation Equity Act: A Legacy for Users” or “SAFETEA-LU”. The Act authorizes \$286.5 billion in funding for surface transportation projects through FY 2009. It also includes several provisions that will enable public funds to be leveraged with private investment through public-private partnerships, including:

- \$15 billion in *private activity bonds (PABs)* for highways and surface freight transfer facilities,
- enhanced authority to use *tolling* to finance construction of interstate highways,
- increased flexibility in using *Design-Build contracting*,
- *streamlined environmental processes*, including a 180-day statute of limitations on actions contesting federal agency approvals for transportation projects, and
- improvements to innovative finance programs, including *Transportation Infrastructure Finance and Innovation Act (TIFIA)* and *State Infrastructure Banks (SIBs)*.

In this case, Mr. Dornan believes that government interference has increased the flexibility in using Design-Build contracting and in turn, promoting the innovative hybrid design-builds.



## Charles

## Commons

Project Type	Contract Type	Number	Percent	\$ Billion	Percent	\$B/Project
Non-Toll Highways	Concession	0	0%	\$0.0	0%	N/A
	DBFO	0	0%	\$0.0	0%	N/A
	DBOM	4	17%	\$1.1	13%	\$0.264
	BOT/BTO	0	0%	\$0.0	0%	N/A
	BOO	0	0%	\$0.0	0%	N/A
	<b>DB</b>	<b>12</b>	<b>50%</b>	<b>\$6.4</b>	<b>81%</b>	<b>\$0.533</b>
	Mgt Contract	8	33%	\$0.5	6%	\$0.061
	Subtotal	24	100%	\$7.9	100%	\$0.331
Toll Highways	Concession	5	18%	\$5.7	22%	\$1.140
	DBFO	2	7%	\$1.5	6%	\$0.765
	<b>DBOM</b>	<b>5</b>	<b>18%</b>	<b>\$10.5</b>	<b>41%</b>	<b>\$2.098</b>
	BOT/BTO	3	11%	\$1.2	4%	\$0.386
	BOO	0	0%	\$0.0	0%	N/A
	<b>DB</b>	<b>12</b>	<b>43%</b>	<b>\$6.8</b>	<b>26%</b>	<b>\$0.565</b>
	Mgt Contract	1	4%	\$0.1	0%	N/A
	Subtotal	28	100%	\$25.8	100%	\$0.920
Toll Bridges	Concession	1	13%	\$1.8	57%	\$1.800
	DBFO	0	0%	\$0.0	0%	N/A
	DBOM	0	0%	\$0.0	0%	N/A
	<b>BOT/BTO</b>	<b>2</b>	<b>25%</b>	<b>\$0.4</b>	<b>13%</b>	<b>\$0.208</b>
	<b>BOO</b>	<b>4</b>	<b>50%</b>	<b>\$0.1</b>	<b>3%</b>	<b>\$0.021</b>
	<b>DB</b>	<b>1</b>	<b>13%</b>	<b>\$0.9</b>	<b>27%</b>	<b>\$0.860</b>
	Mgt Contract	0	0%	\$0.0	0%	N/A
	Subtotal	8	100%	\$3.2	100%	\$0.395
Toll Tunnels	Concession	0	0%	\$0.0	0%	N/A
	DBFO	0	0%	\$0.0	0%	N/A
	<b>DBOM</b>	<b>1</b>	<b>100%</b>	<b>\$4.0</b>	<b>100%</b>	<b>\$4.000</b>
	BOT/BTO	0	0%	\$0.0	0%	N/A
	BOO	0	0%	\$0.0	0%	N/A
	DB	0	0%	\$0.0	0%	N/A
	Mgt Contract	0	0%	\$0.0	0%	N/A
	Subtotal	1	100%	\$4.0	100%	\$4.000
Toll Bridges & Tunnels	Concession	0	0%	\$0.0	0%	N/A
	DBFO	0	0%	\$0.0	0%	N/A
	DBOM	0	0%	\$0.0	0%	N/A
	BOT/BTO	0	0%	\$0.0	0%	N/A
	<b>BOO</b>	<b>1</b>	<b>100%</b>	<b>\$0.6</b>	<b>100%</b>	<b>\$0.600</b>
	DB	0	0%	\$0.0	0%	N/A
	Mgt Contract	0	0%	\$0.0	0%	N/A
	Subtotal	1	100%	\$0.6	100%	\$0.600
Total Road Projects in U.S.	Concession	6	10%	\$7.5	18%	\$1.250
	DBFO	2	3%	\$1.5	4%	\$0.765
	<b>DBOM</b>	<b>10</b>	<b>16%</b>	<b>\$15.5</b>	<b>37%</b>	<b>\$1.555</b>
	BOT/BTO	5	8%	\$1.6	4%	\$0.315
	BOO	5	8%	\$0.7	2%	\$0.137
	<b>DB</b>	<b>25</b>	<b>40%</b>	<b>\$14.0</b>	<b>34%</b>	<b>\$0.562</b>
	Mgt Contract	9	15%	\$0.6	1%	\$0.066
	Total	62	100%	\$41.5	100%	\$0.669

Figure 7: United States Transportation Infrastructure Projects by Contract Type from Daniel L. Dornan in "Synthesis of Public-Private Partnership Projects For Roads, Bridges & Tunnels From Around the World 1985-2004." This shows that although hybrid design-builds do not comprise as many projects as DB, DBOM and Concession projects far out-rank DB in total contract awards.



# Charles

# Commons

## Commuter Rail Infrastructure Market

The rail infrastructure market has proven to be more supportive of design-build hybrids than highway infrastructure. One reason for lack of DBOM/BOT projects in highway markets can be attributed to the inherent necessity for tolls to make investment profitable. Since ticket fares are standard in the commuter rail industry, investment risks are lessened. In addition, large-scale commuter rail projects are still a tough sell in big cities and most local governments try to shed the risk associated with these projects by implementing design-build hybrid deliveries. However, as will be discussed in the case studies, shedding all risk associated with these types of projects can have its downfalls.

In recent years, very few commuter rail projects are outside of the realm of Design-Build. Since these systems are technologically advanced and the designers of these rail systems are more efficient at building them, Design-Build is a no-brainer. However, a majority of these Design-Build projects in the United States are DBOM. As mentioned by Fred Kessler, partner with Nossaman, Guthner, Knox & Elliott in “Managing Contractual Risk: The Project Owner’s Perspective,” “nine of the last fourteen contracts awarded in commuter rail are DBOM instead of DB.”

Figure 8: The following is a map of the United States depicting where these commuter rail projects have taken place. This shows that DBOM has become most prevalent at the metropolitan areas at the far corners of the country.

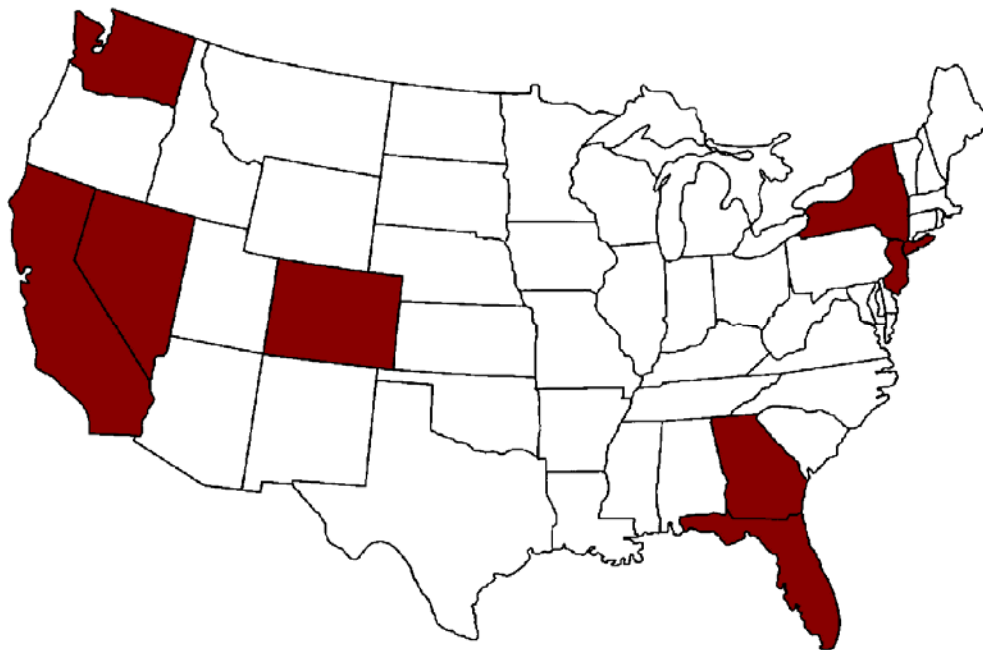

One significant problem with forecasting this market is that there currently have been no studies performed like those of Mr. Dornan’s for the highway





# Charles

# Commons

infrastructure market. So far, this market is growing two-fold; owners asking for DBOM bids from the start and owners switching from DB to DBOM contracts (such as in Miami and Denver). More in-depth studies will most likely be published in the next few years documenting this trend.

## *Utility Infrastructure Market*

Utility companies and local governments across the country are on the leading-edge of a construction boom to replace or repair America's aging infrastructure. It has been well-documented in the national news that as England moves to catch-up with its aged utilities, the American government has ear-marked millions of dollars for sorely needed utility upgrades such as canals, sewage facilities, and water treatment facilities. As published by ENR on February 27, 2006, concurrent with this report, showed that the strongest sectors of the public construction industry is the power utilities, the highway and street, the sewage and waste disposal, the water supply, and conservation and development industries.

The power utility industry abroad, such as in China and India, are using the benefits of BOT. As shown later, the Shajiao B Power Station in China will be compared to the Tolt River and Cedar Water Treatment Plant in Seattle to weigh the benefits as recognized by these projects.

## *Building Construction Market*

In the building construction market, DBOM is being tested for the first time in the Pacific Northwest region. Two projects in Washington and Oregon are on the cutting-edge of project delivery innovation and are scheduled for completion this Spring. Since DBOM involves long-term contracts during the operations and maintenance terms of these projects, the complete picture will not be reported for decades. However, since the design phases for both of these projects are nearing their end, it is important to study their contributions and the efficiencies attributed to DBOM. Later in this report, these two projects will be the center of a more-detailed case study since their successes will be the most applicable to Charles Commons.

As for the other design-build hybrids, no known building projects are implementing these contracts in the United States. A variation of DBOM/BOT is being tested by the Vancouver Redevelopment Authority in British Columbia, Canada for redevelopment of several urban blocks. Mixed-use buildings and a convention center is planned for Vancouver, where alternative project deliveries were considered due to a lack of funding and an authority that is trying to minimize their risk. It is believed that some future large projects such as stadiums, convention centers, and urban redevelopment initiatives may require these alternatives in the United States. Currently, that remains to be seen.



# Charles

# Commons

## Civil Infrastructure Case Studies

In this section, case studies were performed in the civil infrastructure markets to make comparisons between the different design-build hybrids and find their advantages and disadvantages. The following projects are used as case studies:

### Commuter Rail Infrastructure

- Seattle Monorail Project, DBOM
- Hudson-Bergen LRT, DBOM
- JFK AirTrain, DBOM
- Las Vegas Monorail, DB
- Taiwan High Speed Rail, BOT

### Highway Infrastructure

- Dulles Greenway, DBFO
- Route 3 North Improvements, BOT

### Utilities Infrastructure

- Tolt River and Cedar Water Treatment, DBOM
- Shajiao B Power Station, BOT

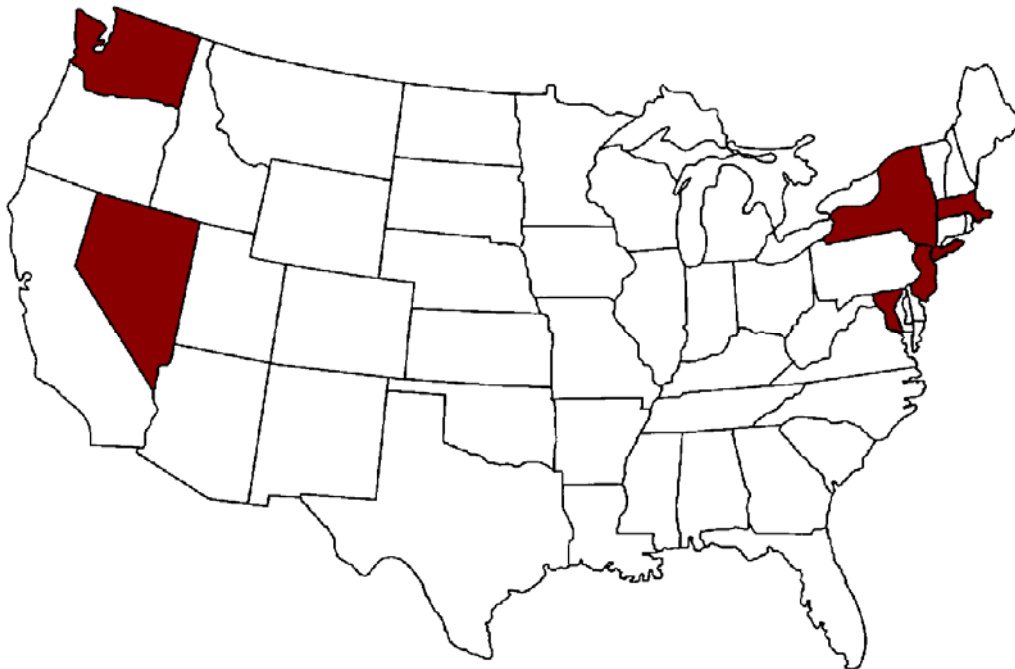
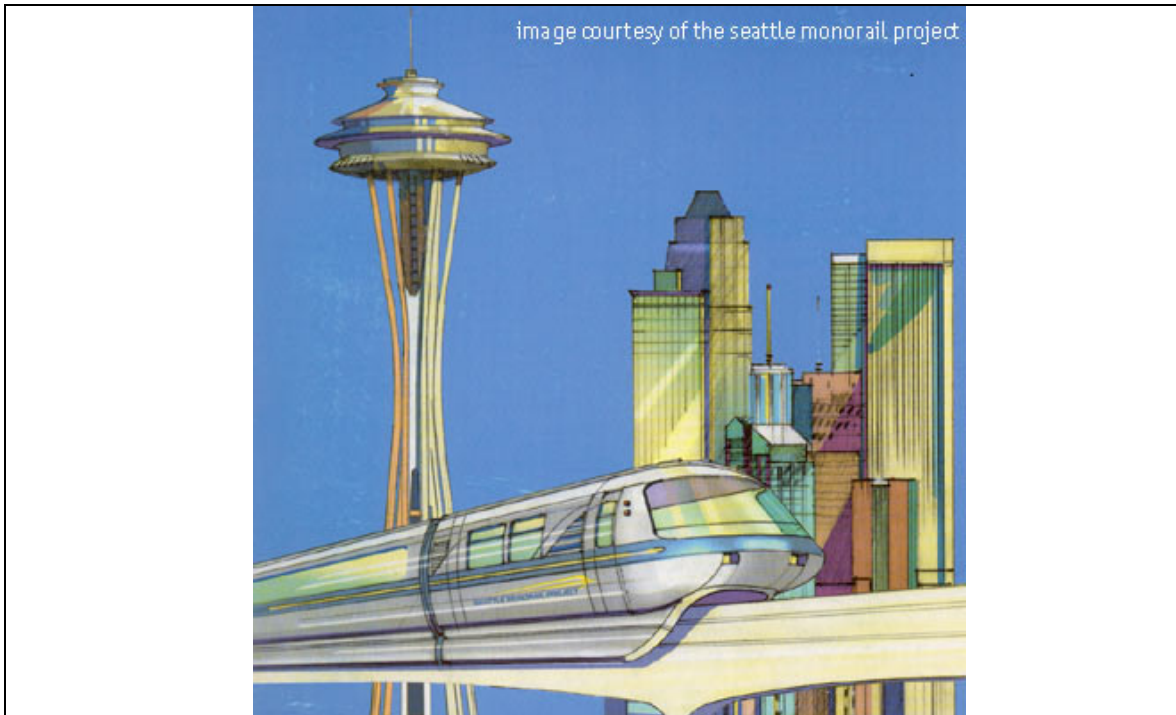

Figure 10: The following is a map of the United States depicting where the civil infrastructure case studies are located. The projects outside the U.S. are located in Taiwan and the Guangdong province in China.



# Charles

# Commons



Project Name:	SMP Green Line
Team:	The Cascadia Monorail Company: Fluor Enterprises, Inc.; Hitachi Ltd.; Mitsui USA; HDR Engineering, Inc.; Howard S. Wright Construction Co.; Hoffman Construction Company; Atkinson Construction; RCI Construction Group; Concrete Technology Corporation; VANIR Construction Management; David Evans and Associates; Kleinfelder, Inc.; PanGeo; Buckland & Taylor; PB Transit and Rail Systems, Inc.; H.W. Lochner, Inc.; Praha Strategies, Inc. (Patrick Kyles); Alcatel Transport Automation, Inc.; Bear, Stearns & Co., Inc.; Berger/ABAM Engineers, Inc.; EDAW; Hellmuth, Obata & Kassabaum (HOK); Wilson Ihrig & Assoc., Inc.; White Electrical; Holmes Electric, PSI, and Doris Locke & Associates
Owner:	Seattle Monorail Project Authority (SMP)
Contract:	Design-Build-Operate-Maintain
Contract Length:	15 years
Construction Schedule:	2003-2009
Total Project Cost:	\$1.5 billion
O&M Cost/year:	\$24,530,000
Project Description:	14-mile Green Line that will stretch from north to south and will connect many of Seattle's key destinations

# Charles



# Commons

## *Logic for Using Alternative Delivery Method*

The Seattle Monorail Project Authority (SMP) had completed numerous studies detailing the efficiencies of Design-Build-Operate-Maintain over other delivery methods. According to a December 2002 report that is referenced in the DBOM Update published in January 2004 written by Nancy C. Smith and Philip Castellana, DBOM is described as:

- *DBOM acts as an effective “quality hook” in design and construction of projects, incentivizing the project designer to consider enhancements to project quality to reduce operations and maintenance expense and to avoid system failures and resulting decreases in system availability.*
- *DBOM provides significant benefits with regard to system integration and reduces risks relating to system integration by requiring the designer, builder and supplier to work together.*
- *DBOM diminishes the challenges of start-up problems, claims and system integration.*
- *DBOM provides early certainty regarding design, construction and operation and maintenance costs, reduces opportunities for cost growth and increases likelihood of achieving financial targets.*
- *DB/DBOM encourages use of innovative, cost-saving approaches that can be highly beneficial to the project.*
- *DB can greatly accelerate the completion schedule and provide schedule certainty; DBOM enhances the schedule certainty advantages provided by DB.*

To add to the December 2002 report, Smith and Castellana expand on the efficiencies of the DBOM delivery relating to the following aspects: on-time delivery, maintaining budget, break-even by 2020, excellent design, and accountability to the public. These aspects are compiled in the chart on the following page comparing a true DBOM contract with that of separate contracts. Although the results are not completely different, the advantages of DBOM are called out very clearly. In this case, DBOM would clearly allow the SMP to meet all of their goals and have decreased the risk to levels not common on large projects. These advantages will be referenced later when the delivery methods are compared.





# Charles

# Commons

**ABILITY OF DIFFERENT O&M APPROACHES  
TO ACHIEVE SEATTLE MONORAIL PROJECT GOALS AND POLICY OBJECTIVES**

GOAL	DBOM	DB WITH O&M CONTRACTED OUT TO THIRD PARTY	DB WITH IN-HOUSE O&M
<b>ON TIME DELIVERY</b>			
<ul style="list-style-type: none"> <li>Early certainty re schedule</li> </ul>	Yes	Yes	Yes
<ul style="list-style-type: none"> <li>Delivery within schedule</li> </ul>	High probability	High probability Note: additional interfaces increase risk of delayed opening	High probability Note: additional interfaces increase risk of delayed opening
<b>DELIVERY UNDER BUDGET</b>			
<ul style="list-style-type: none"> <li>Early certainty re construction cost</li> </ul>	Yes	Yes Note: Price likely to be higher than for DBOM approach due to Contractor uncertainty regarding interfaces with third party operator	Yes Note: Price likely to be higher than for DBOM approach due to Contractor uncertainty regarding interfaces with third party operator
<ul style="list-style-type: none"> <li>Avoidance of construction cost growth</li> </ul>	Probable	Probable	Probable
<b>BREAK EVEN ON OPERATIONS BY A DATE CERTAIN</b>			
<ul style="list-style-type: none"> <li>Early certainty re O&amp;M costs, thus facilitating planning to achieve goal</li> </ul>	Base O&M costs are fixed (subject to escalation provisions), pricing provided for 15 years of operations	O&M cost must be estimated for planning purposes; actual amount will be determined only when the contract is awarded; contract will probably be short-term, reducing value of information for planning purposes.	O&M cost must be estimated for planning purposes; little information available for purposes of long-term planning
<b>EXCELLENT DESIGN</b>			
<ul style="list-style-type: none"> <li>High quality design/construction</li> <li>Addressing life-cycle cost</li> <li>Efficiently managing system integration and transition to operations phase</li> </ul>	Probable--DBOM provides incentives for contractor to address O&M issues during design and construction.  Due to the complexity of the system and likelihood of glitches during the initial operations period, the system designer and supplier is the best qualified to correct start-up challenges, achieve reliability most quickly and avoid claims and disputes between multiple contractors or contractor and owner.	Since there is no built-in incentive to improve design to reduce life cycle costs, the owner should consider alternative means of achieving that goal.  This approach would require owner to manage interface between design/construction and O&M personnel, creating opportunity for contractor claims and allowing arguments that O&M contractor	Since there is no built-in incentive to improve design to reduce life cycle costs, the owner should consider alternative means of achieving that goal.  This approach would require owner to manage interface between design/construction and O&M personnel, creating opportunity for contractor claims and allowing arguments that

GOAL	DBOM	DB WITH O&M CONTRACTED OUT TO THIRD PARTY	DB WITH IN-HOUSE O&M
		caused problem. Also, owner would need to hire O&M staff/consultants to provide input into design and construction.  Note: Third party probably will not be able to perform as well as the system supplier during the initial operations phase. If problems arise during O&M period, contractor may claim they are due to faulty maintenance or operator error.	O&M personnel caused problem. Also, owner would need to hire O&M staff/consultants to provide input into design and construction.  Note: Owner probably will not be able to perform as well as the system supplier during the initial operations phase. If problems arise during O&M period, contractor may claim they are due to faulty maintenance or operator error.
<ul style="list-style-type: none"> <li>Environmental sustainability</li> </ul>	Yes (contract performance standards and compliance mechanisms required).  Note: SMP's sustainability team believes there is an advantage to DBOM due to built-in incentives to consider life-cycle cost. Many sustainability solutions have higher up-front costs, but cost can be recouped with lower operating costs (e.g. regenerative braking and low voltage lighting)  Contract includes provisions incentivizing contractor to minimize power usage.	Yes (contract performance standards and compliance mechanisms required).	Yes (contract performance standards and compliance mechanisms required during DB phase; direct owner control during O&M phase)
<b>TRUE TO GRASSROOTS HISTORY: TRANSPARENCY AND ACCOUNTABILITY TO PUBLIC</b>			
<ul style="list-style-type: none"> <li>Social sustainability (family wages/benefits)</li> </ul>	Yes (O&M contract performance standards and compliance mechanisms required)	Yes (contract performance standards and compliance mechanisms required)	Yes (direct owner control)
<ul style="list-style-type: none"> <li>Diversity (during O&amp;M phase)</li> </ul>	Yes (contract performance standards and compliance mechanisms required). Note: DBOM offers long-term opportunity to strategize and collaborate with the contractor. RFP requirement to including up-front proposals on diversity during O&M stage requires proposers to focus on key opportunities over life of project.	Yes (contract performance standards and compliance mechanisms required)	Yes (direct owner control)

Charles



Commons

Figure 13: The above chart by Smith and Castellana compares DBOM with other variations of O&M in-house and contracted to a third party. In most of these areas of analysis, the risk is consistently minimized and acceptable for the SMP.

*Alternative Delivery Performance*

Despite its promising attributes, a negative public vote in the city of Seattle on November 8, 2005, the Seattle Monorail Project was shut down. The design and construction services implemented by Cascadia Monorail Company had been terminated and the effects of DBOM on the SMP will never be known. But, the extensive studies performed by the SMP have laid the framework for future projects.



# Charles

# Commons



Project Name:	Hudson-Bergen LRT
Team:	21st Century Rail Corporation: Perini/Slattery, STV, Washington Infrastructure Group, Itochu Rail Car, and Kinkisharyo USA
Owner:	New Jersey Transit
Contract:	Design-Build-Operate-Maintain
Contract Length:	15 years
Construction Schedule:	1995-2000
Total Project Cost:	\$1.3 billion
O&M Cost/year:	\$63 million
Project Description:	15-mile, 16 station, 29 vehicle, manually-operated light rail system

*Logic for Using Alternative Delivery Method*

Most information regarding DBOM at the Hudson-Bergen LRT was found through the previously cited 2004 report by Smith and Castellana. According to Smith and Castellana in their 2004 report to the SMP:

*New Jersey Transit's representatives felt that use of a single procurement for both DB and O&M resulted in a much better product, particularly since the equipment supplier was part of the DBOM consortium. On Hudson-Bergen, there was much better integration than would otherwise be expected. The representative also felt that by using DBOM, New Jersey Transit*

## Charles



## Commons

*avoided disputes between agency operating personnel and the contractor as to whether a problem was due to bad design or bad maintenance.*

Once again, a transit authority decided that DBOM could best achieve the goals of the prescriptive specifications and, most importantly, achieve operations and maintenance goals not typically found in construction.

#### *Alternative Delivery Performance*

The Hudson-Bergen LRT was found to be quite successful for New Jersey Transit. Since this project was the first of its kind to use a DBOM delivery, it was honored with the American Public Transportation Association's Innovation Award in 2000. As in any project there were a few disputes about the payment structure. Again, as cited in the 2004 report by Smith and Castellana:

*The maintenance provided by the O&M contractor is much better than that on agency-operated systems. However, there have been problems in operations, including the contractor's use of a commercial/financial approach to risk management affecting safety issues, and slow response times. For future DBOM contracts, one representative said he would want a different payment structure giving the agency more direct control over operations, i.e. paying on a time and materials basis rather than having a fixed base price. He noted that there is less reason for a large experienced transit agency with substantial in-house resources to use DBOM, but stated that he would recommend DBOM for new small agencies.*

In addition to conflicts on payment structure, conflicts may arise from organized labor dealing with the pay rates of the operations staff, since a DBOM contract awarded at the beginning, as with Design-Build. As cited by Smith and Castellana:

*New Jersey Transit received union complaints that it was "giving work away" by using DBOM. In fact, the Hudson-Bergen O&M workers were organized one week before commencement of operations. The labor union representative who was interviewed for this survey identified several areas of concern in dealing with the operating company. He recommended that any DBOM contract require the O&M contractor to pay rates comparable to those paid to workers in other systems, and require the contractor to have a labor relations liaison on its management staff.*

The problems with union complaints and operations pay structure can be added as line items in the DBOM contract from the beginning to help with these issues. Overall, the Hudson-Bergen LRT has been a model DBOM project for the Commuter Rail market and will continue to be studied as the O&M contract reaches conclusion.





# Charles

# Commons



Project Name:	JFK Airtrain
Team:	Air Rail Transit Consortium: the joint venture of Perini, Bombardier, Slattery/Skanska (USA), Karl Koch Erecting, and STV Group
Owner:	Port Authority of New York and New Jersey (Port Authority)
Contract:	Design-Build-Operate-Maintain
Contract Length:	10 years, with (2) 5-year options
Construction Schedule:	1998-2003
Total Project Cost:	\$1.16 billion
O&M Cost/year:	\$25 million
Project Description:	8-mile automated transit system, with 3 stations, serving JFK

*Logic for Using Alternative Delivery Method*

The applied logic for using DBOM on the JFK Airtrain was formed by forming the goals of the owner and contractor, write in provisions in a contract to achieve these goals, and address key areas in which the DBOM process itself must be scoped. First, the goals of the owner and contractor were discussed during the RFP meetings and the following table was created as shown in the following table.

## Charles



## Commons

OWNER	CONTRACTOR
Open system on time	Open system on time
Safely meet or exceed passenger service criteria and amenities	Safely meet service criteria (to avoid penalties)
World class system image	Maximize profit during design-build phase
System is maintained within budget to as-new standards	Maximize profit during Operations and Maintenance period
System is serviceable and durable beyond the end of the Operations and Maintenance period	Maintain corporate reputations

Figure 18: As shown in the 2004 report on the JFK Airtrain by Cracchiolo and Simuoli, both the owner and contractor goals were taken into consideration under the DBOM contract written in 1998. It is important for both entities to participate in the DBOM contract to make it a success.

Second, the contract provisions must be agreed upon by the participants of the DBOM contract in order to achieve the goals. The following text is from Cracchiolo and Simuoli from the same 2004 report in which they document the specific contract provisions:

*Provisions included in the contract:*

- Port Authority standard clauses such as compensation for extra work, time for completion and damages for delay, and provisions for extensions of time.
- Corporate guarantees in place of performance and payment bonds.
- Provisions to limit contractor and owner risks, and incentives to limit claims.
- Contingency Fund covering amounts for:
  - Contaminated and hazardous material disposal
  - Changed subsurface conditions
  - Maintenance and protection of traffic
  - Utility relocation
  - Idle salaried workers and equipment
  - Various delay events not due to Contractor (up to one year)
  - Conditions and precautions for construction work on railroad property
- Contingency Fund provision provides the Contractor a 40% contingency fee (bonus) of the amount remaining in the Contingency Fund at the conclusion of the Contract.
- Overruns are Contractor's risk

In DBOM projects, it is typical to see corporate guarantees, risk provisions, and incentives to limit claims since the project is typically one highly scrutinized. Large contingency verbage gives the Design-Builder incentive to carefully calculate the contingency and try to absorb the contingency fee bonus to make the project much more profitable.

Finally, Cracchiolo and Simouli discuss the important key areas in which the JFK Airtrain addressed to minimize the hardships during the contract:



# Charles

# Commons

*Key areas in which the DBOM process that must be carefully addressed: scope definition, parties' duties and responsibilities, schedule, payments, change orders and claims, product quality, intellectual property, 3<sup>rd</sup>-party agreements, dispute resolution, and O&M incentives.*

In addition, Smith and Castellana stated in their 2004 report that the “representatives of the Port Authority of New York and New Jersey (Port Authority) stated that the basic reason for using DBOM was to obtain guarantees of the technology. The system provider would not guarantee what another entity operates, and a third-party operator would not provide availability guarantees for a system built by another entity. Particular advantages noted by these representatives were the ability to commence use of discrete systems prior to completion of the entire system, and the quality of employee training provided by the O&M contractor.”

### *Alternative Delivery Performance*

The use of Design-Build-Operate-Maintain was crucial to the success of the project, although the project team were faced with their own share of dilemmas. For example, there was a 1-year delay in start of operations due to an accident during manual operations in testing as noted by Smith and Castellana. Accidents happen quite frequently in construction and to have a testing accident before opening allows operations the opportunity to learn. Other lessons learned from the JFK Airtrain project include the following from Cracchiolo and Simouli:

#### *Design and Construction*

- *Develop well defined contracts*
- *Develop good performance criteria*
- *Define key roles and responsibilities*

#### *Risk Management*

- *Develop a balanced allocation of risk between owner and DBOM contractor*
- *Allow the contractor to proceed "at risk" when appropriate*

#### *Project Management*

- *Establish and maintain open communications channels*
- *Allow "fast track" design submittal review to accommodate early construction/building of key project elements*
- *Establish third party agreements early on*
- *Accept innovation*
- *Develop and execute risk mitigation strategies*

Most of these lessons can be attributed to all construction projects, but good performance criteria, balanced allocation of risk, establish third-party agreements, and execute risk mitigation strategies are very important to the success of a DBOM project.



# Charles

# Commons



Project Name:	Las Vegas Monorail
Team:	Liase Corporation, Bombardier Transportation, Granite Construction Company, Gensler & Associates, Carter-Burgess, and Salomon Smith Barney.
Owner:	The Las Vegas Monorail Company
Contract:	Design-Build
Contract Length:	5 years, with (2) 5-year options
Construction Schedule:	2000-2004
Total Project Cost:	\$354 million
O&M Cost/year:	\$11.2 million, 5 year initial with 5 year options
Project Description:	3 miles of dual-elevated guideway, 7 stations, 9 four-car trains

*Logic for Using Alternative Delivery Method*

The design-build contract for the Las Vegas monorail is entered into by the owner on one side and the Granite Construction Company and Bombardier on the other. This is what is known as a three-party contract. In addition, the owner entered into a separate O&M contract with Bombardier. The contracts were not bonded, but backed by the parent companies, as done in many DBOM contracts to make the parent companies feel more is at stake in the project.



# Charles



# Commons

## *Alternative Delivery Performance*

After many delays, the Las Vegas Monorail opened to the public on July 15, 2004. During testing and commissioning, the monorail suffered several malfunctions that delayed the start of passenger service for almost a year. The most severe of these problems related to parts falling from the monorail to the ground under the tracks. On September 8, 2004, more problems with falling parts led to the closing of the monorail for nearly four months. It reopened on December 24, 2004. A number of repairs were made to the monorail cars during this shutdown. Each time the monorail system requires major engineering changes, it must undergo a lengthy "commissioning" process to confirm the effectiveness and safety of the repairs. The local press reported that each day the monorail was down cost the system approximately \$85,000, and that over \$8.3 million was lost as a result of this one shutdown.

Despite the problems with start-up, since the two contractors were joint liabilities for the delivery of the project, the owner did not have to determine which of them was at fault for the delay in opening and the subsequent shutdown. Since liquidated damages ensued, the two contractors battled in court over the responsibility to getting the project done in time. Therefore, this type of limited liability approach using Design-Build has proven an effective tool for the owner in escaping litigation.



## Charles

## Commons



Project Name:	Taiwan High Speed Rail
Team:	Taiwan Shinkansen Company (TSC), Kawada Industries, AEC, HOCHTIEF, Bilfinger+Berger, and Continental Engineering Corporation
Consortium:	Taiwan High Speed Rail Co., Ltd.
Contract:	Build-Operate-Transfer
Contract Length:	35 years
Construction Schedule:	2000-2006
Total Project Cost:	\$16 billion
O&M Cost/year:	n/a
Project Description:	214 mi high speed rail including many miles of viaducts

*Logic for Using Alternative Delivery Method*

The main reasoning for choosing Build-Operate-Transfer was the inability of the transit authority in Taiwan to fund such a large project, although the need for high-speed rail was great. Thus, the Taiwan High Speed Rail Co., Ltd was born. As mentioned by John E. Schaufelberger in a 2005 ASCE Construction Research Congress paper 7547 titled "Risk Management on Build-Operate-Transfer Projects":

*In addition to developing and operating the rail system, the project sponsor was given the right to undertake property development around the ten stations for a period of 50 years. The*

# Charles



# Commons

*Ministry of Transportation and Communications assumed all responsibility for land acquisition and arranged a government loan at a fixed interest rate.*

These added stipulations allowed the owner, who is involved in a concession agreement with the Taiwanese government, to use the land benefits of this contract to make up the expenses of the project. However, the relationship with the Ministry of Transportation and Communications, which was responsible for land acquisition, deteriorated as the project wore on.

### *Alternative Delivery Performance*

According to Schaufelberger, the project fell behind schedule early due to delayed land acquisition, but the project sponsor was not compensated for the delay, because a schedule for delivery of the land was not specified in the contract. In addition, the sudden devaluation of the Taiwanese currency in 1997 increased project costs by about \$500 million. The effects from delayed land acquisition could have been avoided if a clause was written into the contract allowing the consortium to be reimbursed for delays caused by the government. However, the devaluation of the Taiwanese currency is not a political risk that can be avoided, showing one issue facing BOT's.



# Charles

# Commons



Project Name:	Dulles Greenway
Team:	Brown & Root, Autostrade International of Virginia, O/M, Inc.
Consortium:	Toll Road Investors Partnership II (TRIP II): Bryant/Crane family, AIE, L.L.C., and Kellogg Brown & Root, Inc.
Contract:	Design-Build-Finance-Operate
Contract Length:	42.5 years
Construction Schedule:	1988-1995
Total Project Cost:	\$385 million
O&M Cost/year:	\$7.1 million
Project Description:	14-mile extension of the Dulles Toll Road, connects Dulles International Airport with Leesburg, Virginia.

*Logic for Using Alternative Delivery Method*

Enabled by the 1988 action of Virginia 's General Assembly, authorizing private development of toll roads, TRIP II constructed a 14 mile extension of the Dulles Toll Road. The Virginia Corporation Commission limits the rate of return on the project to 18 percent, but profits appear unlikely to approach which will be explained later. As stated by Schaufelberger in his 2005 paper, “As a result of the Design-Build-Finance-Operate delivery, the project completed six months ahead of schedule.”

# *Charles*



# *Commons*

## *Alternative Delivery Performance*

Although design and construction amounted to a success, the profitability of the Dulles Greenway has continuously been an issue. When traffic fell short of projected levels one year after completion, TRIP II defaulted on their loans. After toll decreases and still facing financial challenges, TRIP II restructured its debt in 1999 and agreed to an extension of the project.





# Charles

# Commons



Project Name:	Route 3 North Improvements
Team:	Modern Continental Construction Company
Consortium:	Route 3 North Transportation Improvements Association, a tax-exempt 63-20 corporation whom issued 30-yr bonds
Contract:	Build-Operate-Transfer
Contract Length:	30 years
Construction Schedule:	2001-2004
Total Project Cost:	\$385.1 million
O&M Cost/year:	N/A
Project Description:	Lane addition along 21-mile stretch, 40 bridge replacements, and improvements to 13 interchanges

*Logic for Using Alternative Delivery Method*

According to the Route 3 website, there are four major reasons for choosing a design-build hybrid: demand for quick completion, limit cost and schedule risk, complete the project during an adjoining project, and take advantage of financing innovation to reduce project costs. The demand for quick completion and advantage from the financing innovation are not “sure” results as shown previously with projects like the Las Vegas Monorail. However, they understand the lessened liability they face if the project was to suffer delays or cost overruns.

# *Charles*



# *Commons*

## *Alternative Delivery Performance*

On October 2004, three travel lanes were open in each direction on the full 21-mile length of the highway. The additional work on roadway overpasses and interchanges have been delayed and should complete by Spring 2006. So far, there are no cost overruns or litigation on the project.



# Charles

# Commons



Project Name:	Tolt River and Cedar Water Treatment
Team:	Camp Dresser &McKee/Azurix/Dillingham
Owner:	Seattle Public Utilities
Contract:	Design-Build-Operate-Maintain
Contract Length:	15 years with (2) 5-year options
Construction Schedule:	Tolt: 1997-2000 Cedar: 2001-2004
Total Project Cost:	Tolt: \$101 million Cedar: \$109 million
O&M Cost/year:	Tolt: unknown Cedar: \$1.25 million/year
Project Description:	300-million gallon per day drinking water treatment plants

*Logic for Using Alternative Delivery Method*

The logic for Seattle Public Utilities for choosing Design-Build-Operate-Maintain was the ability to control costs and allow a private entity to operate and maintain the remote facility. In addition, Seattle Public Utilities wanted to guarantee the O&M costs for the next fifteen years despite fluctuations in the economy.

*Alternative Delivery Performance*

Seattle Public Utilities completed the Tolt River Water Treatment Plant in 2000, on schedule and within budget, and completed the Cedar Water

# Charles



# Commons

Treatment Plant months ahead of schedule and under budget. According to Smith and Castellana:

*The agency representatives interviewed strongly believe that these results are tied to the fact that the contracts include operations. They also believe that the capital cost savings are tied to the high level of industry interest in the O&M work. (Contracting out operations is widely used in the public water industry and is very competitive.) They particularly cited contractual incentives and liquidated damages for a number of factors (e.g., water quality) as effectively motivating the contractor to perform to a high standard during the 24-month operation period to date. The agency also had strong goals regarding diversity and sustainability and wages that they achieved using DBOM.*



## Charles

## Commons



Project Name:	Shajiao B Power Station
Team:	Modern Continental Construction Company
Consortium:	Hopewell Power (China) Ltd.: Hopewell Holding, Kamematsu Goshu, HK
Contract:	Build-Operate-Transfer
Contract Length:	10 years
Construction Schedule:	1984-1987
Total Project Cost:	\$530 million
O&M Cost/year:	N/A
Project Description:	(2) 360 MW coal-fired plants

*Logic for Using Alternative Delivery Method*

As the first Build-Operate-Transfer project in China, the Shajiao B Power Station was on the leading edge of innovative delivery practices. Frequent blackouts in the Guangzhou province in China lead to the Shenzhen Special Economic Zone Power Development Co. to be formed. This group of prominent government and business professionals decided that the urgency called for an immediate bidding process inviting concessions to build two coal-fired power plants as soon as possible. A BOT contract was awarded to Hopewell Power (China) Ltd. and to promote early completion, a major incentive was built into the agreement between Shenzhen and Hopewell that any proceeds from electricity sold before March 31, 1988, less the agreed costs, would be credited to Hopewell.

*Alternative Delivery Performance*

The incentive program and delivery method decision proved successful. Shajiao B was tested, commissioned, and in full commercial operation within 33 months, while the synchronization of power-generating Unit 1 was completed within 2 years (11 months ahead of schedule) from the handover of the construction site. According to Schaufelberger, the project was a complete success:



# Charles



# Commons

*"The power plant construction not only set a world record in speed, but was done with high quality. One party to the joint venture, Hopewell, later received an award for Superior Civil Engineering from the United Kingdom in performing the project," said Eddie Ho, director of Hopewell Power (China) Ltd.*

*Up to July 31, 1999, it had sold 42.2 billion kwh of electricity, an enormous contribution to the stability and peak loading of the provincial power system. In its initial stage, the station produced 3.7 billion kwh of electricity each year, which was nearly one fourth of the generation total of the province's power system. The power shortage was to some extent alleviated and the investment environment of Guangdong Province was greatly improved.*

*It is surprising to find that the first BOT project completed was a total success. The power station was transferred to Chinese control in 1997.*

*Charles*



*Commons*

*Building Construction Case Studies*

In this section, case studies were performed in the building construction market to investigate how the design-build hybrids can be used for Charles Commons and future building projects. However, there are only two building projects in the United States using design-build hybrids. All two are located in the Pacific Northwest region and implement Design-Build-Operate-Maintain as their chosen delivery method.

Since these projects were the closest match to Charles Commons, a more-detailed case study analysis needed to be performed. A project delivery questionnaire was distributed amongst the professionals on each project, including the owner representative for Charles Commons to find more-detailed first-hand information. More questions were asked when the professionals submitted their questionnaires to understand the idiosyncracies of the projects, instead of the generalities. Only at the completion of this analysis, design-build hybrids can be compared for the Charles Commons project.

The projects that are analyzed in this section are the Clackamas County Public Services Building in Oregon City, Oregon and the University of Washington Research & Technology Building in Seattle, Washington.



# Charles

# Commons



## Clackamas County Public Services Building

Team:	Hoffman Construction, Group Mackenzie, Johnson Controls
Owner:	Clackamas County Public Services
Contract:	Design-Build-Operate-Maintain
Contract Length:	30 years
Design Schedule:	July 2003 – February 2004
Construction Schedule:	July 2003 – July 2004
Total Project Cost:	\$16.9 million
O&M Cost/year:	\$96,408/year
Use:	110,000 sf administrative space

### *Logic for Using Alternative Delivery Method*

Clackamas County is a growing Oregon community of 362,000 in an area of urban and rural mixes. County workers have outgrown their existing space in 17 offices spread out around the county and running lease costs of \$154,000. The overall goal of the county government was to consolidate all of the facilities into one campus to make the smallest impact on the environment and save on facilities cost. As the concept of the Public Services Building was discussed in the county government, three major issues required a streamlined construction process:

- Lease Deadlines – 17 local offices needed to move out of their leases at an exact time

# Charles



# Commons

- Financing – with funding secured at a low 4.11% interest rate for 30 years, construction needed to begin immediately
- Steel Prices – using DBOM allowed the project the ability to secure steel prices before the steeper rises.

In order to conquer these issues, Clackamas County had to act as soon as possible. The county decided to solicit bids for a Design-Build-Operate-Maintain contract.

## *Project Description*

The four-floor building is approximately 110,000 SF and located on a 6.52-acre parcel of the Red Soils site in Oregon City. The building's systems include fire alarms, sprinklers, electrical, cable, telecom and data, lighting, audio-visual, security, and automation. A 450-ton chilled water HVAC system heats and cools the building.



The facility also features bioswales for stormwater run-off and a series of trails and educational signs designed for public use throughout wetlands on the property. Other technology includes a low-temperature HVAC system and a Web-based Metasys® building management system used to tie together many intelligent systems that improve operations and management. Indoor environmental quality measures such as carbon dioxide monitoring and use of low-emitting materials complemented an environmental quality management plan during construction and a two-week flush-out before occupancy.

Additional sustainable features include lights that sense the amount of daylight entering the building and adjust to maintain optimum levels (and save energy at the same time), and a cooling tower that is electro-statically cleaned so chemicals are not released into the drainage water. Reflective panels and louvers work in concert with light harvesters to automatically control lighting based on the amount of available natural light, and the building is zoned into variable air volume boxes.

## *Design and Construction*

After selecting the team of Hoffman Construction, Johnson Controls, and Group Mackenzie by way of best-value, the design and construction got underway immediately. At the beginning of design, Hoffman Construction and Johnson Controls project management staff were present to offer constructability reviews, value engineering, lifecycle advice, and sustainability advice. Clackamas County had decided to achieve LEED Certified Silver status for the project and this was taken into considerations in all aspects of design.

## Charles



## Commons

Upon Group Mackenzie's preliminary design, Johnson Controls designed and worked as a single-source for MEP Coordination for the project. Allowing Johnson Controls design and coordinate the MEP systems helps shorten the commissioning process and allows the building to be turned-over quicker. In addition, the entity with the greatest familiarity with the installed systems stays on to operate the systems, which is very efficient. In addition, County officials signed an energy performance contract with Johnson Controls. The contract guarantees the county will realize energy savings for 15 to 20 years. Johnson Controls will monitor, operate and maintain the systems for the 20-year period. If the systems don't deliver the energy savings promised, Johnson Controls is obligated to pay for the difference and correct the system. These types of guarantees are what separates DBOM from all other deliveries, where in other projects distrust and litigation clauses reign.



Almost immediately after ground was broken, Hoffman Construction began excavation and foundation work on the 6.52 acre site. Since the site is large, very few problems with sequencing, deliveries, and coordination developed. Otherwise, the steel building was construction like any other office building construction.

The MEP system components were installed on the heels of the structural contractors. Since MEP was coordinated through Johnson Controls, all of the systems were installed prior to wall construction. Some aspects of green design, such as the two-week system flush-out, added to the schedule, but the savings in commission more than compensated for the lost time. The building was turned over to Clackamas County exactly one year after breaking ground, which Johnson Controls attributes to be a savings of seven months.

### *Operations and Results*

According to Johnson Controls, the project saved in two areas:

*Lifecycle Costs* — Because Johnson Controls installed and guaranteed the performance of high-grade equipment over 20 years, the building is estimated to avoid \$1.8 million in repair, maintenance and energy expenses as compared to a building constructed at minimum code compliance. By focusing on lifecycle cost as opposed to first cost, the building also is 40% more efficient than ASHRAE 90.1. The project gathered approximately \$346,000 in energy rebates and tax credits.

*Operating Costs* — The county's costs are expected to be reduced by nearly \$64,000 per year compared to a typical office building. For instance, by having county offices share resources and



# Charles



# Commons

*equipment such as copiers and printers, the county will save in equipment leasing and renewal costs. Most importantly, the co-location of services helps Clackamas County provide a higher level of customer service. Citizens needing services and information can quickly and easily have a variety of their needs met through the professional services centrally located at the PSB.*

In addition, the county received \$206,684 from the State of Oregon by reselling the available Business Energy Tax Credit, and \$47,370 from the Energy Trust of Oregon's New Building Efficiency program. The project received an award for excellence by the DBIA-Northwest region.



# Charles

# Commons



## University of Washington Research & Technology Building

Team:	CollinsWoerman, M.A. Mortenson, Johnson Controls
Owner:	University of Washington
Contract:	Design-Build-Operate-Maintain
Contract Length:	30 years
Design Schedule:	November 2003 – February 2005
Construction Schedule:	July 2004 – March 2006
Total Project Cost:	\$29,850,000
O&M Cost/year:	\$125,000/year
Project Use:	Six floors and 122,000 sf of research space 65-parking space garage

*Logic for Using Alternative Delivery Method*

The Research & Technology (R&T) Building project was conceived to help meet the growing need for flexible, cost-effective facilities to support multi-disciplinary research initiatives at the University. The project will provide space for physical science laboratory research in the general areas of nanotechnology,

*Bryan A. Quinn*

*Advisor: Dr. Michael Horman*

*Construction Management*

*2006 AE Senior Thesis*



# Charles

# Commons

photonics, genome technology, information technology, energy, biometrics, and others. The space is intended for research projects that need to be on the Seattle campus and are subject to the on-campus indirect cost recovery rate. While being owned by the University, the building cost and rent must be competitive with the private sector and should provide predictable occupancy and life-cycle costs over 30 years.

### Project Description

The six-floor, 122,000 sf UW Research & Technology Building is carved out of the side of a steep incline. Its structure is comprised of cast-in-place concrete flat plate slabs and its façade is glass and masonry. The building is located the closest of all on-campus buildings to downtown Seattle. There is close proximity to the Puget Sound, in which dewatering wells were required to excavate for the building's foundation. There are also 65 parking stalls located in the lower two stories of the building.



### Design and Construction

The Mortenson/CollinsWoerman/Johnson Controls team won an intense competition to design, construct, operate, and maintain the UW Research & Technology building. The following table shows how the team fared with schedule early-on:

Schedule (start - finish)	Planned	Actual
Conceptual Planning	12/10/02 - 9/23/03	12/10/02 - 9/23/03
Design	10/14/03 - 12/14/04	11/17/03 - 4/17/05
Procurement	5/21/04 - 7/9/04	5/21/04 - 6/29/04
Construction	7/9/04 - 3/21/06	7/9/04 - not complete
Close-out	3/21/06 - 1/20/07	3/9/06 - not complete

As shown above, the only delay thus far is the delay in design. From correspondence with CollinsWoerman, a 3-D modeling process was used to coordinate building systems. This digital modeling process, which is not frequently used in the Pacific Northwest, was implemented at the middle part of preparing construction documents.

# Charles



# Commons

The process of identifying system conflicts continued floor to floor starting in the CD process through MEP coordination phases of construction. Each of these “processes” were performed in meetings in which all trades were involved.

In addition to design for the base building project, each leased space will require a tenant fit-out, which has been coordinated to use the services of Mortenson/CollinsWoerman/Johnson Controls through University of Washington. So far, three research tenants are spending at least \$6 million to lease space in the UW Research & Technology Building before it is complete.



The 19-month schedule of the UW Research & Technology building is on-track. Thus far, the structure has been complete and the interior finishes are wrapping-up. The most important aspect, the commissioning process is about to begin and the true test of the added O&M input has yet to begin.

### *Interview with CollinsWoerman*

Two respondents with the architect on the project, CollinsWoerman, gave important information about the processes of the project. In a phone interview with John Whitlow, the project architect, he discussed the overall design and its challenges. First, he stated that the design delays that were incurred on the project were not due to the inefficiencies of the design process. Since the project lies on the outskirts of the University of Washington campus, permitting with the City of Seattle was required. The building permit was delayed several times by the City of Seattle due to problems with the site design, since the building is on such a tight site. These problems were rectified after being delayed for months.



## Charles



## Commons

In addition, the owner and contractor were very involved in the design process. They both took on the responsibility of managing design and design decisions could be answered quite quickly. During construction, two owner representatives would visit and get daily construction reports from the superintendents. The owner and architect were inexperienced with DBOM prior to this project and the contractor was the least experienced with high-technology laboratories. Mortenson's experience was derived from the Clackamas County Public Services Building project that was previously described. There was not a formal value engineering process during design since the contractor was present to weigh-in at real-time on the best-value.

The first respondent, Jon Szczesniak, worked on the digital modeling required for the coordination of the high-tech laboratory. The floor-to-floor height was reduced from 15' to 13'-6" as a result of the digital modeling. The introduction of digital modeling was described by Mr. Szczesniak in the following:

*It's important to realize that out here, in Seattle, the idea of digital coordination is fairly fresh. There have only been a handful of projects that have used this to it's fullest capacity. I believe it was Mortenson who had originally brought up the idea of modeling the building in three dimensions for the explicit purpose of coordinating the different trades that were to make up this Research & Tech. building. They have done similar processes on the Disney Concert Hall, and it is becoming their standard way to work with architects and all subs.*

The primary purpose of the 3D modeling was for MEP coordination, which began in the middle of the construction document phase. It was Jon Szczeniak's opinion that if the 3D modeling was started earlier, at the beginning of the design development phase, the design could have been coordinated between the professional engineers and not require the added coordination costs incurred by the subcontractors. Nevertheless, Mr. Szczeniak went on to describe the process:

*... the design sequence/timeframe was from the CD phase through construction. We got together every other Tuesday and went through the project. Each floor was separated out and coordinated by itself. We used specialized software that would allow us to view the building stereoscopically in real-time so that we could see that when plumbing had a collision with electrical, we could zoom right to it and see how to best resolve the issue. Each coordination meeting had parties from all trades.*

Mr. Szczeniak and Mr. Whitlow believed that this MEP coordination process was a success that saved the UW Research & Technology Building in lower building height, construction conflicts, and access issues. Without the project team cooperation that results from a DBOM delivery, the UW Research & Technology Building may not have achieved the cost and schedule benefits from 3-D MEP Coordination.



# Charles



# Commons

## *Johns Hopkins University – Charles Commons Analysis of Alternative Delivery Methods*

The Charles Commons project is part of the Johns Hopkins University plan to expand their residential services to allow their students more options while attending the Homewood Campus. When students reach sophomore, junior, or senior status, they had typically left the on-campus housing and found off-campus apartments to share with their friends. Since the 1990's, there has been a trend to supply suite apartments to upperclassmen who still want to remain in touch with the on-campus crowd. JHU's most recent master-plan had called for thousands of beds of capacity to be constructed over the next ten years. Johns Hopkins University will not meet this goal with the traditional methods being used on Charles Commons.

### *Existing Project Delivery Method*

The project delivery method on Charles Commons is best described as ever-changing and all-encompassing. The project began with the intentions of using the traditional Design-Bid-Build method. However, as the development teams were introduced to the project, the method used changed to CM@Risk under a GMP contract. However, as the cost of the project increased, the dining hall component was added, and the design schedule lengthened, the developers decided to employ SBER under a CM Agency agreement in a lump sum contract. Currently, the project is a CM Agency.

### *Analysis Criteria*

Using the information compiled from the case studies, questionnaires, and interviews, I will investigate the advantages and disadvantages for using the following alternative project delivery methods at Charles Commons:

1. A Design-Build contract awarded through best-value and employing the O&M services of JHU Office of Facilities Management.
2. A Design-Build-Operate-Maintain contract awarded through best-value and employing the services of a full-service O&M contractor in all parts of the project at a length of 15 years with options up to 30 years.
3. A Build-Operate-Transfer contract awarded to a consortium consisting of a development firm, financier, contractor, designer, and an operations & maintenance contractor. Ownership can be transferred to JHU after 30 years.

At this time, these alternatives could not be implemented because of the policies of the JHU Board of Regents. The Board of Regents require CM@Risk, CM Agency,

# Charles



# Commons

and Design-Bid-Build contracts only. It is the ultimate goal of this report to introduce owners to the benefits of design-build hybrids and hope that they consider them in their decision-making processes for the future.

## *Interview with JHU Facilities Management*

On February 1, 2006, I interviewed Mike DiProspero, a senior project manager with the Johns Hopkins University Office of Facilities Management about the project he is closely involved with, Charles Commons. In addition to the walkthrough interview at the jobsite, he completed my Project Delivery Questionnaire, whose comments are listed below. I want to take this time to thank him again for all of his help.

At this time, the project is under a Design-Bid-Build delivery with Lump Sum payment terms. The University is a private entity and has earmarked money from personal donations to make capital improvements such as Charles Commons. Mr. DiProspero has much experience outside of this project with other project deliveries and feels that the delivery system is adequate for its use on Charles Commons.

The schedule began to slip in October of 2004 when design needed more time to complete the newly added Dining Hall component. This one month delay translated into a two month delay (from June 2004 to August 2004) in construction when difficulties arose in negotiations with an existing tenant that refused to leave early. Specialized abatement was needed for the demolition of Ivy Hall, diminishing the opportunity to make-up time. Excavation for St. Paul proved difficult since rock was found sooner than expected. An inability to contract the caisson subcontractor delayed the beginning of caissons on St. Paul. In addition, relocation of utility lines on the corner of the site by BG&E caused an enormous delay in utility work. All of these troubles minimally delayed the superstructure of St. Paul. More delays were yet to come.

The additions to the program, such as the Dining Hall component and Conference/Banquet Facility and scope changes contributed to a \$600,000 design increase and a \$10 million construction increase. Increased material escalation, such as steel and concrete, at bid time also added to the unexpected cost increases. Cost cutting processes, called value engineering by the team, were implemented during the changes in a failed attempt to maintain the original budget.

The overall project experience for all parties involved has been quite stressful, but Mike DiProspero attributes most of the headaches to unforeseen conditions and typical problems in design and construction. He commented about the excellent relationship that team has with him. In addition, he commented about the excellent experience the contractor and designer has with similar facilities and the project delivery system. Although there were many lessons to be learned from this project, Mr. Prospero noted that he would not have changed the team or the project delivery method.

# Charles



# Commons

## 1. Design-Build

A Design-Build contract was first considered when analyzing the inefficiencies in the schedule (without mentioning unforeseen conditions). Demolition, utility and foundation excavation, and mobilization needed to occur before design was approximately 50% for the greatest overlap of the design and construction activities. Contractor input can be facilitated from the beginning of the project and could perform constructability reviews, value engineering, and MEP coordination during the entire design process.

In addition, the Design-Build contract would protect the developers from the negative effects of unforeseen conditions and maintain the controlling hand in negotiation or litigation. The risk-limiting attributes of Design-Build is what attracts many savvy owners to this delivery method. The owner could facilitate design with less staff using performance specifications.

The bidding process would need to be changed to a best-value evaluation process, which may require more investigation of the program and bidding requirements, increasing the initial bidding process approximately 50%. In addition, the contract would be written on fixed lump sum terms where the Design-Builder takes on most of the risks associated with the project. The Design-Builder could very well be a joint-venture between SBER and Design Collective, especially since they have worked together well many times before.

## 2. Design-Build-Operate-Maintain

A DBOM contract was considered when discussions were held regarding value engineering at the past year's S:PACE Roundtable meetings dealing with Design Management. DBOM would work to improve the design and construction processes as in Design-Build, with the added improvements in lifecycle value engineering. Not only would the owner use performance specifications to make sure he experiences the best value, but the entire project's focus will be on what amounts to 75% of the project's cost, its operations and maintenance.

The O&M contractor can be integral during design to facilitate energy savings concepts and sustainability. A quality O&M contractor such as Johnson Controls or Siemens could operate and maintain the off-campus building as well as JHU's Office of Facilities Management at a controlled cost. This control allows the developers to not be liable when expensive equipment malfunctions, as it may be prone to do under conventional contract terms. Incentivizing design and construction to concentrate on "getting it right" will promote the quality standards expected from Johns Hopkins University facilities.

The bidding process would need to be a best-value evaluation on fixed lump sum basis as discussed with Design-Build. In addition to a joint-venture between SBER and Design Collective, an O&M contractor would need to be partner as well.

# Charles



# Commons

### 3. Build-Operate-Transfer

A BOT contract was considered soon after discussing the development taking place in the vicinity of the project. The existing Owner-Developer-Contractor structure allows itself well to an integration with other projects in the area. The \$90 million student apartment development taking place near by is spear-headed by a team made up of the developers Canyon-Johnson and SBER under a loan from the Citibank Community Development Fund. Capstone and SBER are developing \$64 million Charles Commons. The integration of these two development teams would create a strong BOT team capable of \$154 million in development of 863,000 sf of dormitories and apartments for Johns Hopkins University.

The most important benefit of this structure for Johns Hopkins University is its risk allocation. All risk, including political risk, are handed over to the BOT partners. This would allow the team to use economies of scale to design, construction, finance, operate, and maintain Charles Commons, Charles Village East, Charles Village West, Village Commons, and the Village Lofts.

The bidding process would need to be a best-value evaluation as discussed with the previous two delivery methods. In addition to the two development teams, the integration of an O&M contractor would be preferable.

#### *Comparison of Delivery Methods*

On Charles Commons, an experienced owner and team allows the possibilities of using alternative delivery methods. Although the existing team experience using Design-Build is not a strength, the team does have experience with one another. The risks associated with DBB are high in comparison with all of the other delivery methods. Problems such as steel prices, unforeseen conditions, and subcontractor woes would be the responsibility of the design-build team, not the responsibility of the developers. Below is an estimate of the schedule for Charles Commons if the alternate delivery methods were used.

To secure a reasonable estimate as to the schedule benefits of one delivery method over another, the schedule of the UW Research & Technology building and JHU Charles Commons were compared. The overall complexity of both projects



# Charles

# Commons

Charles Commons Schedule by Delivery Method

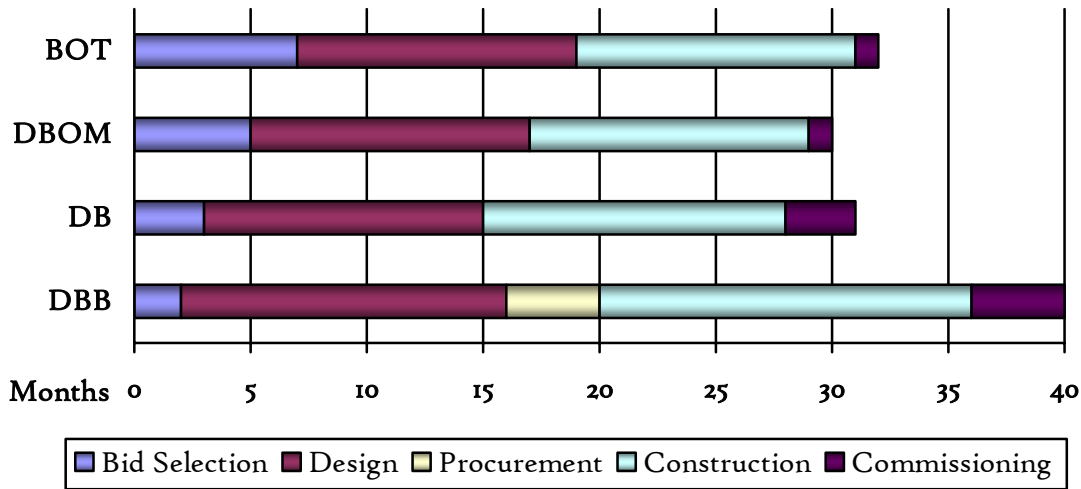

Figure 45.1: Estimates were made by comparing lengths of five different stages of the Charles Commons project. The existing schedule is attributed to the DBB method and the other methods were subsequently compared by stage duration.

Delivery	Risk	Experience	Schedule	Cost Control
DBB	Responsible for all risks associated with project	<b>None required</b>	Short bid selection Longer design & construction	Least value Low initial costs/high O&M costs Many CO's
DB	Political, O&M, financial risk, single liability	Team experience required	Longer bid selection Shorter design & construction	High value High initial costs/lower O&M costs Less CO's
DBOM	Political, financial risk	Owner & Team experience required	<b>Longer bid selection</b> <b>Shortest design &amp; construction</b>	Highest value Highest initial costs/lowest O&M costs Less CO's
BOT	<b>Political</b>	Owner & Team experience required	Longest bid selection Shortest design & construction	<b>Highest value</b> <b>Low initial costs/low O&amp;M</b> <b>Owner does not have ownership initially</b> <b>No CO's</b>

Figure 45.2: Comparisons between the delivery methods were made using four main issues: risk, experience, schedule, and cost control. BOT and DBOM were consistently better than the other delivery methods.





# Charles

# Commons

The table above compares the delivery methods by risk, experience, schedule, and cost control. The bolded areas are aspects of the project that are the most favorable. Since team and owner experience is not an issue on Charles Commons, only DBOM and BOT show exceptional performance characteristics. The only difference between DBOM and BOT is the financial risk, initial ownership, and initial bid selection.

## *DBOM/BOT Conclusion*

Design-Bid-Build is inappropriate for Charles Commons compared to the design-build hybrids. Design-Bid-Build is responsible for the cost increases due to the added owner risk and longer design and construction. Charles Commons is nearing 650 PCO's due to the Design-Bid-Build delivery in addition to quality problems.

Design-Build is an improvement over DBB for Charles Commons. The risk pertaining to the steel and concrete prices, the unforeseen conditions, and design problems are eliminated from the contract, helping the developer maintain the budget of \$54 million and giving the developer the upperhand in negotiations regarding these risks. Since JHU employs their own O&M staff from the campus and have consulted since 20% design on operations, Design-Build is an effective method for O&M. In addition, the estimated schedule benefits for Design-Build are a reduction of 8 weeks.

Design-Build-Operate-Maintain is the most appropriate delivery method for Charles Commons in respect to completing the project in time for Fall '06 opening. The savings of 10 weeks is critical to allow for the numerous delays and risks incurred on the project. DBOM may not be the most cost-effective initially, but the delivery allows the project to save the owner on lifecycle costs. The integration of an additional contractor to conduct O&M activities should not prove problematic for the experienced team. However, the JHU Board of Regents have rejected DBOM proposals in the past.

Build-Operate-Transfer also proves advantageous for the developers of Charles Commons. The schedule of BOT is the same as DBOM with the exception of the longer time to set up the financing of the project. BOT proves to be the least risky for JHU when the developers take on all of the risk of the project. In addition, change orders are eliminated. However, without JHU owning Charles Commons outright, some of their technologically-advanced equipment and high-quality may be sacrificed unless all of the specifications were performance instead of prescriptive. This time-consuming specification process may not be practical for the highly bureaucratic Johns Hopkins University. JHU must trust the design-builder to not sacrifice the quality of the overall project since JHU will not be in the position to own the project for some time.

Since there is a lack of owner quality control during the BOT design and construction term, BOT is not in the best interest of the JHU at this time. In addition, an outside O&M contractor may be more innovative and technologically-



# *Charles*

# *Commons*

advanced in comparison with JHU Office of Facilities Management. Secondly, an outside O&M contractor will allow for more efficient MEP coordination such as digital modeling and can perform the MEP design and work to act as a seamless single entity for the design, construction, operations, and maintenance of the building. And finally, the extra two weeks of schedule savings proves that DBOM is a better choice for Charles Commons than Design-Build.



# Charles

# Commons

## Market Outlook

Of the aforementioned markets, DBOM and BOT have different growth opportunities. DBOM and BOT futures can be forecast by analyzing the following:

1. Regions in which the owners are familiar with the trend and press articles have been released
2. Regions that have passed legislation and projects have been completed successfully
3. Regions or projects that have extraordinary demand for DBOM/BOT techniques (for example, power plants in the Southwest)
4. Current growth with reference to the origin projects of DBOM/BOT
5. Growing demand for DBOM/BOT

In the highway market, federal legislation such as SAFETEA-LU has promoted the use of DBOM/BOT delivery methods to streamline the government approval processes and deliver a project in which funding is not readily available.

The light rail train market favors the DBOM method because funding will become more problematic due to the infrastructure crisis. In addition, DBOM/BOT are excellent candidates for the high-speed rail initiative around urban centers along Interstate 95. Cities such as Charlotte, Raleigh, Jacksonville, Richmond, Fredricksburg, Washington, DC, Baltimore, Harrisburg, Philadelphia, New York, and Boston have been interested in building high-speed rail. However, fiscal issues have made this possibility a long shot. The study of BOT on the Taiwan High Speed Rail project may be the shot in the arm that high-speed rail needs.

The demand for new and updated utility infrastructure is far beyond its legislated funding. In addition, successful projects such as the Tolt River and Cedar Water Treatment project demonstrate the benefits of DBOM. BOT can be used for projects in the Southwest where funding is low but demand for electricity is at critical limits.

The demand in the building construction market is marginal for DBOM/BOT delivery methods. More states that pass DBOM/BOT legislation and more owner's executive boards that accept DBOM/BOT will significantly increase the viability of DBOM/BOT on building projects. Currently, only three states have DBOM/BOT legislation. The following table displays the current and forecasted market trends for the design-build hybrids:



# Charles Commons

Markets	Design-Build hybrid	Current (2006)		Future (2016)		Catalysts for Growth
		Market Share	Region	Market Share	Region	
Hi-way	DBOM	< 1%	Across USA	4%	Across USA	SAFETEA-LU, 2005 Federal legislation
	BOT	< 2%	Across USA	4%	Across USA	
Train	DBOM	45%	Across USA	60%	Across USA	High-speed rail for DC/NY corridor
	BOT	0%	Overseas	< 1%	Mid-Atlantic	
Utility	DBOM	< 1%	Seattle	5%	Northwest, Florida	States have passed DBOM legislation
	BOT	0%	Overseas	< 1%	Southwest USA	Not enough funding for power plants
Building	DBOM	< 1%	Northwest	2%	Northwest, Florida	States have passed DBOM legislation
	BOT	0%	Overseas	0%	Northwest	Redevelopment Corporation Laws

Figure 49: Market futures were predicted for DBOM/BOT in each of the four discussed markets drawing information from ENR and other sources. These predictions are highly arbitrary and conservative, but the overall trend of DBOM/BOT deliveries have been widely believed to increase over the next ten years.

It is important for state legislation for DBOM/BOT to be carried out as soon as possible to allow owners this choice for project deliveries. DBOM/BOT can greatly aid public and private owners with their financial, schedule, and lifecycle issues.



# Charles

# Commons

## *Owner's Guide to DBOM/BOT*

In many studies, the selection of a project delivery method for a project is the largest decision the owner can make. The project delivery affects the relationships between the project team members and dictates the incentives on the project. In order to help owners weigh DBOM and BOT with the other delivery methods, an owner's guide to project delivery methods must be created.

### *Background*

Tools for selecting project delivery methods have been on the market for years. Most are in the form of books, where after 300 pages of reading, an owner becomes more confused about the decision that when he had started. The specifics of project delivery selection are wholly dependent on the construction projects that were studied since many of the same projects can have completely different outcomes. Since time is an issue for the owner, the owner's guide must be only a few pages. In addition, the owner's guide must be written for a lay person. Any difficult language (whether vague or advanced) can confuse the owner into a bad decision.

The best project delivery selection system (PDSS) was proposed by Anthony Vesay in his thesis for his Master of Science Degree in Civil Engineering. Mr. Vesay's PDSS Model uses a series of six questions to determine the best course of action. The six questions deal with:

1. Project Characteristics (well-defined vs. poorly-defined)
2. Time (critical vs. not-critical)
3. Owner Experience (experienced vs. inexperienced)
4. Team Experience (experienced vs. inexperienced)
5. Quality (industry-standard vs. above-standard)
6. Cost (critical vs. not-critical)

These questions led the owner to a decision amongst DB, CM@Risk, CM Agency, and DBB delivery methods. In order to add DBOM/BOT to this model, three of these questions must be adjusted to accommodate the different issues associated with the integrated methods versus the traditional methods.

### *Existing Guide Criteria*

The six issues that affect the process of selecting project deliveries are a condensed form of an endless list of variables in a project. As described by Victor Sanvido and Mark Konchar in their book, *Selecting a Project Delivery Method*, the following are additional issues that the owner must consider:

*Project's importance to the owner's future and concurrent projects;*  
*Owner's experience in delivering jobs similar in size, type and location;*





# Charles

# Commons

*Degree of scope definition and potential for changes;*  
*Owner's ability to staff and support the job;*  
*Owner's ability to assume, manage and allocate risk for the project;*  
*Limitations due to procurement practices and laws;*  
*Owner's procurement and purchasing practices;*  
*Expected level of owner involvement;*  
*A pool of qualified team members;*  
*An owner-designated staff to make timely decisions.*

Since there are many issues, it would be most prudent to stay focused on the current six issues, since they seem to encompass the greatest cost or schedule consequences to the decision and are the most affected by the project delivery method.

## *Project Characteristics*

Project characteristics is a vague issue in which the program scope definition is considered as either “well-defined” or “poorly-defined”. First, the vagueness of “project characteristics” can mislead the owner as to its definition. The program scope definition is an important factor in the project delivery decision, but it can be affected by owner by his timeliness in making the project delivery system decision. If the owner takes the time to make performance specifications and other program requirements, he/she would be most prepared to make this decision. In addition, the subjectivity of a “well-defined” vs. “poorly-defined” scope is an issue since it is the owner using this model. I would not be surprised if most owners choose the “well-defined” scope although they do not prescribe to the industry standard.

## *Time*

Schedule can be critical in many ways. If a project begins design requiring completion before a designated move-in date, time can be a critical factor. Time may also be critical if the design completes on a project that cannot be constructed in the required timeframe due to lengthy design. Time is also critical as a way to finance the building itself where the project can be delayed due to the owner's lack of financial support. Again, this is subjective, but it should be assumed that a time-critical project requires fast-tracking and methods that could help streamline design and coordination processes.

## *Owner Experience*

Of the criteria in the PDSS Model, owner experience is the most important. Experienced owners know how to “well-define” a scope, how to limit change orders, and most importantly, how to make quick, best-value decisions for their respective



# Charles

# Commons

projects. But exactly what does the owner have to be experienced in to achieve the “experienced” path? Does the owner need to be experienced in the type of building, type of delivery method, or type of construction? I assume that this asks if the owner is able to make the best decisions during the project that he/she is yet to take on. Owner experience is an aggregate of the past experiences/decisions that the owner had to make in the similar type of building. Again, this is a subjective topic.

## *Team Experience*

Team experience is important to the outcome of the project as well. The experience of the contractor, architect, and engineers with the type of building is important to finding the typical systems and processes without constantly “reinventing the wheel”. However, there are situations in which the team is experienced with itself and not experienced with the type of building that can turn good relationships bad.

## *Quality*

Quality is the most subjective issue on construction projects. A contractor and an owner have two different ideas of “quality” and they require architects and engineers to find common ground. Quality can be construed as “high-technology”, monumental design, durability, and the lifespan of the structure. Durability and lifespan of the structure cannot be ascertained until years after the project’s completion. High-tech laboratories and monuments can be low-quality facilities compared to other facilities of the same likeness. Exactly what is above-standard vs. industry-standard?

## *Cost*

Cost is all-critical on every project. If cost was not critical on a project, a project manager would not be needed on the project because the engineer could specify anything. Value engineering and cost-cutting processes would not be needed if cost was not even somewhat critical. The only difference on the importance of cost is initial costing vs. lifecycle costing. The difference between cost-critical and cost-noncritical items shown on the PDSS Model is negligible; few of the project deliveries are distinguished by cost.

## *Guide Criteria Amendments*

The most subjective of the six criteria listed in the PDSS Model are project characteristics, quality, and cost. The other criteria can be adjusted to become more



# Charles

# Commons

specific, but their distinguishing characteristics will remain. The proposed amendments are financial emphasis, specifications, and type of funding.

## *Type of Funding*

The type of funding (public vs. private) can directly affect the owner's ability to make timely decisions, to fund the project, and to mitigate the political risks associated with public projects. The private owner's ability to bypass the bureaucracy of the government's decision-making process is the sole reason to the widespread growth of Public-Private Partnerships (PPP's). These partnerships allow the private entity to make small critical decisions without submitting the decision to a commission or committee of government/university officials.

The owner's ability to fund the project is greatly increased on public projects compared to private projects. Capital projects must be completed for growth and economic strategies of the government and will be completed even if the local government finds itself in financial turmoil. However, the payment process of the government may also be delayed since it is unlikely the contractor can sue the owner for damages.

The political risks associated with public projects can determine many projects' outcomes. For example, the political risks on the Seattle Monorail Project (SMP) were great and the public voted for the project to end. Administrations change hands and one administration could platform a referendum to halt a capital project of another's. The type of funding will replace the project characteristics to allow the two-page model to be divided public vs. private.

## *Specifications*

The type of specifications can greatly differentiate the traditional methods from the design-builds. Performance specifications, typically used on design-build projects, provide the design professionals criteria in which design risks can be assigned to the design-builder. This risk greatly affects change orders on the project and the importance of cost-control to the owner.

Prescriptive specifications, typical with most building projects, cause the owner to maintain the risk of the designers that he/she employs. A "bad" set of documents can really be problematic for a project in the areas of scope definition and change orders. The type of specifications will replace the quality in order to decrease the subjectivity of the model.

## *Financial Emphasis*

The financial emphasis (initial-cost vs. lifecycle cost) bring together the owner's financial situation and program goals in an accurate assessment of the



# Charles Commons

importance of cost control. The owner’s financial situation will stipulate whether the owner is trying to develop a property to sell, which affects the quality of the building, or if the owner is trying to build a monument (a building that lasts forever). If the owner is under a tight O&M cost schedule with his/her buildings, the owner may make decisions to insure the best long-term investment. The O&M area hints to the owner’s program goals, for which the project team must be counterpart to. The financial requirements area will replace the inconsequential cost section of the PDSS Model.

## *The Integrated Project Delivery System Selection Model (IPDSS)*

This project delivery system selection model integrates all of the traditional and design-build methods of construction. The three amended criteria make the IPDSS effective in differentiating the design-builds from the traditional methods of construction. As shown in the following table, it is difficult to compare the design-builds with each other, but the application of the table to the IPDSS model shows the comparison. The comparison of the traditional methods as analyzed by Vesay have remained the same in most aspects since time, owner experience, and team experience were the largest differentiating factors in Vesay’s PDSS model.

The application of DBOM/BOT to public projects assumes that its use is legal according to the IPDSS model. In many states, the DBOM/BOT initiative has not been fully recognized by the government, although it is forecasted that these delivery methods will become universally-accepted. Also, performance specifications usually require pre-qualification of bidders and a longer pre-bidding program design by the owner. The owner should consider the advantages/disadvantages of performance specifications while consulting this IPDSS model.

### Criteria Comparison for IPDSS Model

Criteria	Criteria Range	Delivery Method
Type of Funding	Public	BOT
		DBOM
		DB
	Private	DBB
		CM@Risk
		CM Agent
Schedule	Fast-track	DBOM
		BOT
		DB
	Normal	CM@Risk
		CM Agent
		DBB
Owner Experience	Experienced	CM@Risk



# Charles

# Commons

	Inexperienced	CM Agent
		DBB
		DB
		DBOM
Team Experience	Experienced	BOT
		DBOM
	Inexperienced	DB
		DBOM
Specification	Performance	BOT
		DBOM
	Prescriptive	DB
		CM@Risk
Financial Emphasis	Initial Cost	CM Agent
		DBB
	Lifecycle Cost	CM@Risk
		DB

Figure 55: The six criteria are compared in this chart to show the comparable nature of the three amended criteria. In each criteria, the design-builds are consistently different than that of the traditional methods.





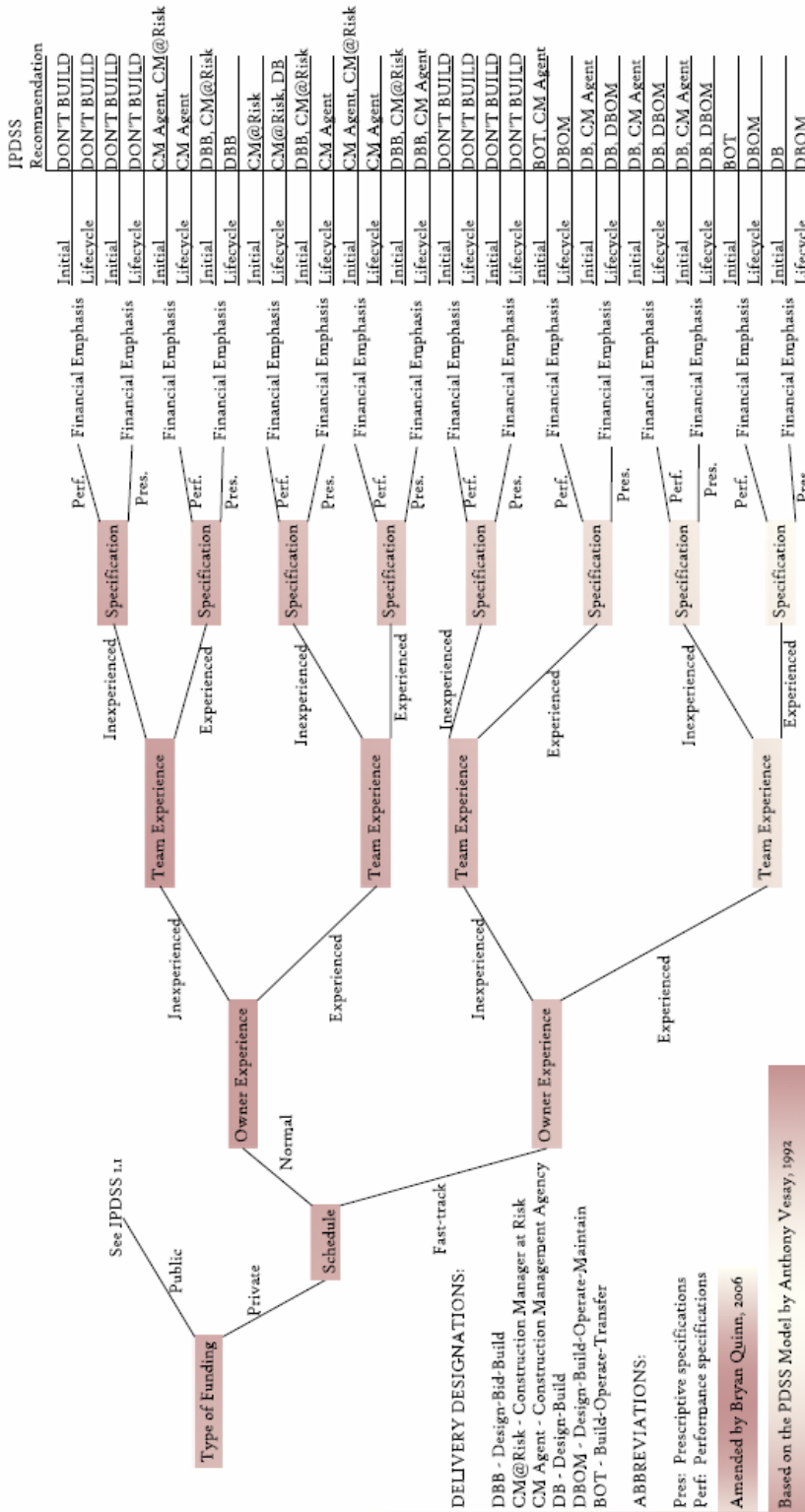

IPDSS 1.2: Integrated Project Delivery System Selection Model (Private Projects)

*Charles*



*Commons*

*IPDSS Conclusion*

In order to create an owner's guide to DBOM/BOT, Vesay's 1992 PDSS model was amended in three categories to effectively compare the design-builds and the traditional methods. The three amended criteria, the type of funding, specification, and financial emphasis, helped shape my Integrated Project Delivery Selection System (IPDSS) into a valuable tool for owners who are hesitant to use DBOM/BOT. The culmination of the case studies, JHUCC analysis, and owner's guide show how DBOM/BOT has been tested, has been effective, and can be used on many applicable building projects.

The PDSS is an ever-changing document because as more methods of delivering construction projects surface, the decision-making process for the owner will change. The IPDSS is an attempt to continue making easy-to-understand documents for owners so that they can make the most-informed decisions. These informed decisions will result in better construction projects and relationships.



# Charles

# Commons

## References

Smith, Nancy C. and Castellana, Philip. January 2004. "DBOM Update, Independent Evaluation of Alternative Approaches Relating to Operations and Maintenance Component of DBOM Contract for the SMP Green Line." Paper presented to SMP Board.

Cracchiolo, Anthony and Simuoli, Victor. 2004. ASCE: Moving Through the Millennium: Automated People Movers VIII. JFK AirTrain: Project Management Issues on a Large DBOM Project.

Paulson, B.C. (1976). "Designing to Reduce Construction Costs." Journal of the Construction Division, 102(Co4): 588.

ENR, Feb 27,2006. Volume 256, Number 8

Construction Research Congress 2005 – Paper 7547, Risk Management on Build-Operate-Transfer Projects. John E. Schaufelberger. Copyright ASCE 2005.

Dahl, Peter and Horman, Dr. Michael et al. Evaluating Design-Build-Operate-Maintain Delivery as a Tool For Sustainability.

Masucci, Maury and Freidheim, Kitty. Airport Owners' Guide to Alternate Project Delivery Systems.

Anonymous Author. White Paper: Project Delivery Methods - Buckman Diversion Project.

Miller, John B. and Garvin, Michael J. et al. Toward a New Paradigm: Simultaneous Use of Multiple Project Delivery Methods. Journal of Management in Engineering, Vol. 16, No. 3, May/June, 2000. Copyright ASCE.

Dahl, Peter. "Finding a Leaner Approach to the Airport Project Delivery Process" The Pennsylvania State University AE Senior Thesis.

Ritchie, Walter D. Alternative Project Delivery. Copyright ASCE 2004.



*Charles*

*Commons*

**Structural Breadth:**  
Design of Partially Post-Tensioned Structural  
Slabs with Alternative Systems





# Charles



# Commons

## *Existing Structure: Partially Post-Tensioned Structural Slabs*

The concrete structure of Johns Hopkins University Charles Commons is mostly a conventional system applicable to most dormitories. There are two foundation systems, spread footings and shallow caissons. There are many continuous reinforced concrete columns that range from rectangular to square dimensions. Shear walls surround the many stair and elevator openings and the precast and brick façade is not load-bearing. Even the penthouse roof structured with typical wide-flange steel beams and metal decking. However, in the slab resides the largest complication for the Charles Commons project team.

The slab is partially post-tensioned, meaning that post-tensioning tendons coincide with rebar reinforcing. A conventional post-tensioning layout was prescribed for the Charles building since the building contains only dormitory space. In stark contrast, only the St. Paul building's top seven floors are exclusively dormitory space. The first three floors of the St. Paul building include a bookstore, a retail space, a conference area, and a full-service dining commons. In addition to the 8" thick post-tensioning slabs, perimeter edge beams and drop panels are implemented throughout to assuage deflection concerns.

### *Charles Building*

The Charles building contains 12 floors that reaches an ultimate height of 153'-4", which is the tallest that the City of Baltimore and Historic Charles Street Association would permit. The 65'x35' footprint affords the Charles building only 100,000 sf. Its small footprint and rectangular shape allows for a structural plan that is nearly uniform throughout the building. The post-tensioned slabs and reinforced columns in the Charles building could be constructed in as little as five days a floor. The foundation of the Charles building began after the fourth floor of the St. Paul building due to staging and utility work. Since the Charles building afforded the construction team very few complications, this building will be spared detailed structural analysis, however, the systems applied on the St. Paul building can easily be extended to the Charles building.

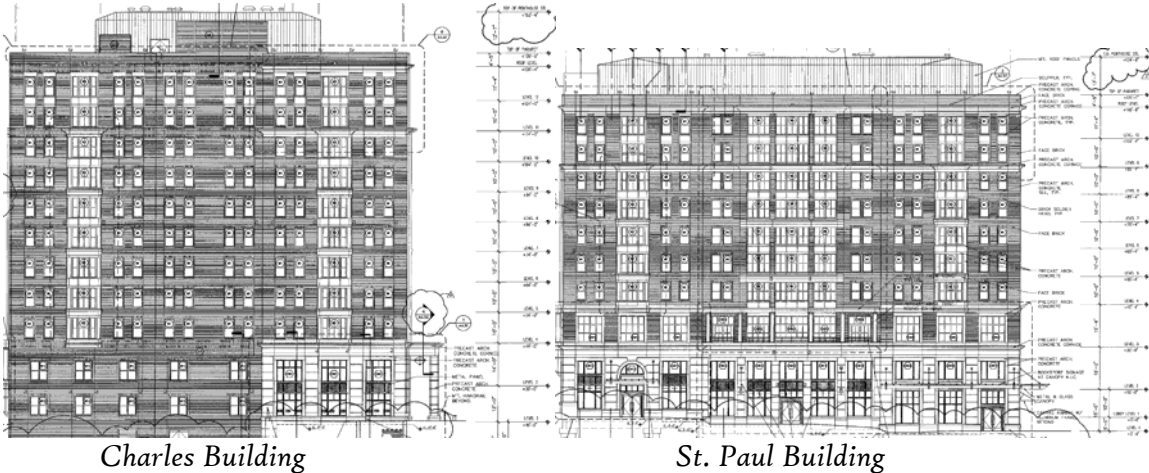
*Charles**Commons**Charles Building**St. Paul Building**St. Paul Building*

This 213,000 sf building towers 134'-8" and ten stories into the Baltimore cityscape. The difference between the two buildings is two stories, or 18'-8", which will be discussed later. Its footprint is quite large at 81'x87'. After the fourth floor, the building resembles a U-shape because of a large interior courtyard space. Before the fourth floor, the building maintains its square shell, but contains many large and odd-shaped floor openings for mezzanines, mechanical shafts, six elevators, four staircases, and a loading dock. To accommodate these large openings and a variety of functions, the engineers have specified two strengths of concrete for the slabs and beams, 6000 psi for the first two floors and 4500 psi for the remaining floors. In addition, the columns on the first two floors are 8000 psi, the next two floors are 6000 psi, and the remaining floors are 4000 psi.

The most frustrating aspect in redesigning the St. Paul building is its column layout. There are no typical bays. Spans range from 18'-29'. All of the columns are either covered in sheetrock and exposed or hidden inside walls. Realignment of columns more than two feet in any direction requires a redesign of the space function, a door or window realignment, and mechanical redesign. However, difficult design layout is not the reasoning to analyze the floors in the St. Paul building.

Three month construction for the first three floors of the St. Paul building is driving force for this analysis. The "custom" design of St. Paul makes it impossible to use the same formwork, the same rebar sequence, and the same concrete mixes. In addition, the problems relating to post-tensioned slabs resonated to the layouts of the mechanical, electrical, and plumbing systems. MEP coordination proved to be costly, delayed, and complicated. Hence, the third analysis will review the results from the structural breadth and propose solutions for MEP coordination success.



# Charles

# Commons

Second Floor Plan

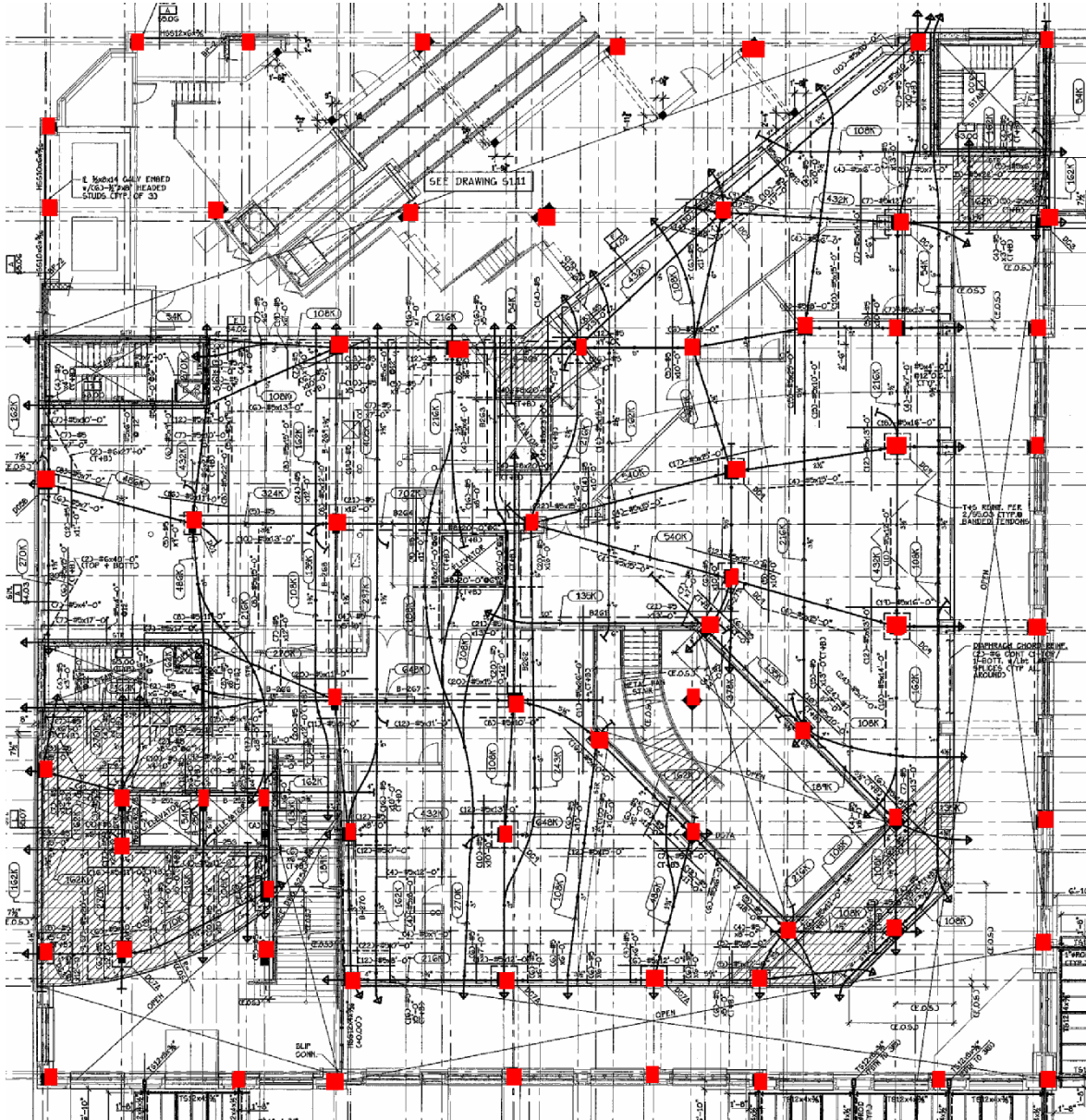

Structure Supports:	Loading docks, lobby, bookstore
Floor Height (1 <sup>st</sup> -2 <sup>nd</sup> ):	15'-0"
Number of Columns:	67
Strength of Columns:	8000 psi
Strength of Slab:	6000 psi
Floor Completed in:	3 weeks

Third Floor Plan





# Charles

# Commons

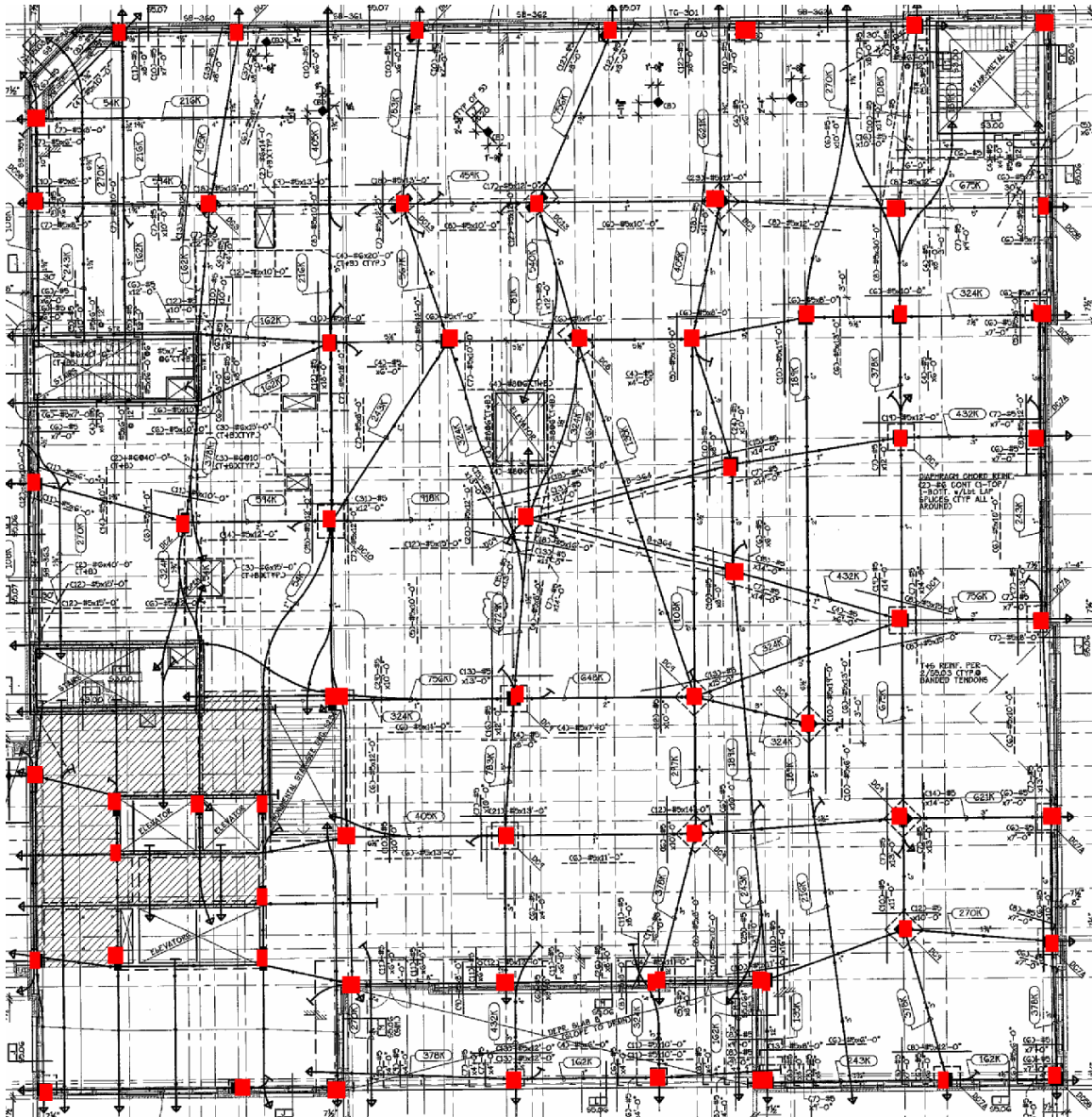

Structure Supports:	Conference room, break-out rooms, dining hall
Floor Height (1 <sup>st</sup> -2 <sup>nd</sup> ):	15'-0"
Number of Columns:	65
Strength of Columns:	8000 psi
Strength of Slab:	6000 psi
Floor Completed in:	6 weeks

Fourth Floor Plan



# Charles

# Commons

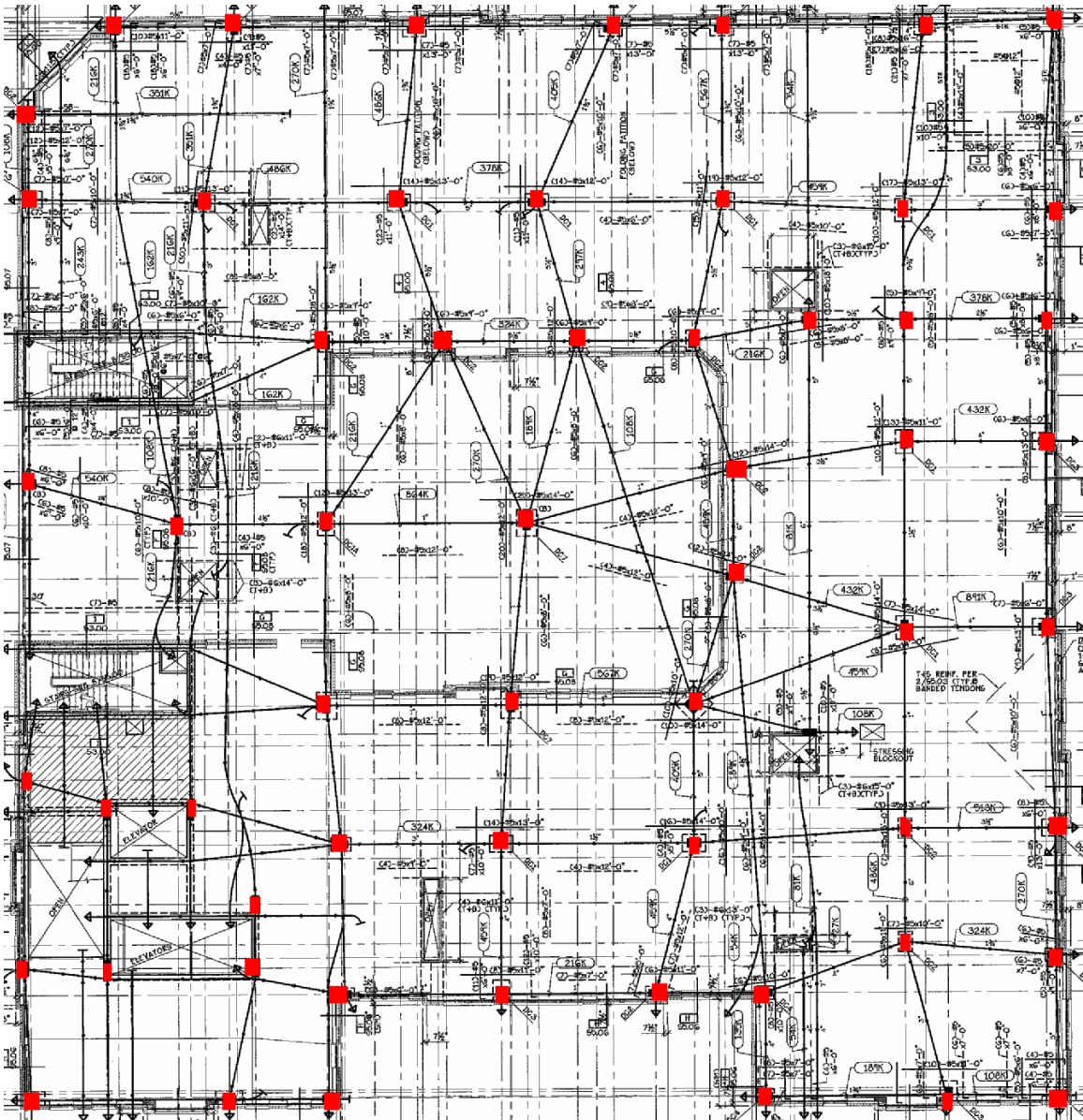

Structure Supports:	Courtyard, lounges, corridors, apartment suites
Floor Height (1 <sup>st</sup> -2 <sup>nd</sup> ):	15'-4"
Number of Columns:	65
Strength of Columns:	6000 psi
Strength of Slab:	4500 psi
Floor Completed in:	6 weeks

### Load Calculations





## Charles

## Commons

Loads and requirements as applicable to the design of the structural floors are:

I.)	Live Loads	
	A. Penthouse	30 psf
	B. Roof	30 psf
	C. Stairs	125 psf
	D. Public Rooms	100 psf
	E. Corridors	100 psf
	F. Dormitory Apartments	40 psf
	G. Dining Hall	125 psf
	H. Office	50 psf
	I. Retail	125 psf
II.)	Dead Loads	
	A. Slab – 8” thick	100 psf
	B. Bearing concrete shearwalls	20 psf
	C. Superimposed MEP	8 psf
III.)	Strength Requirements	
	A. Concrete (28 day strength)	
	i. Walls	4000 psi
	ii. Columns	4000, 6000, 8000 psi
	iii. Slabs, beams	4500, 6000 psi
	B. Steel (Yield Strength, $F_y$ )	
	i. Reinforcement bars	60 ksi
IV.)	Steel Cover Requirements	
	A. Slab on Grade	1”
	B. Beams/Columns	1-1/2”
V.)	Post-Tensioning	
	A. Compressive strength at transfer	2,700 psf
	B. Steel yield strength	270,000 psf
	C. Effective stress after losses	189,000 psf
	D. Preliminary long term losses	15,000 psf

*Existing Structural Floor System*

The current floor system for the sampled floor, the second floor, is an 8” partially post-tensioned system. The loads on the floor slab are the 8 psi superimposed dead load and 125 psi live load. The self-weight of the 8” slab is approximated at 100 psi. The spans vary from 18’ to 29’ between 24”x24” columns typically.

Post-Tensioned Slab



## Charles

## Commons

Slab Thickness	8"
Concrete Strength	4500 psi, 6000 psi
Concrete Volume	5259 CY
Reinforcement Weight	350 ton
Self-weight	100 psf
Column Sizes	24"x24", 24"x12"
Column Volume	609 CY
Building Height	134'-8"

Post-Tensioned Slab	Issue	Reason
Advantages	Structural Code	Does not limit depth of slab
	Rebar Placement	Needed in only one direction
	Formwork	Requires less edge formwork for thinner slab
	Building Height Requirements	Allows the maximum capacity of tenant space in areas with building height limits
Disadvantages	Safety	Snapped stressed tendons are catastrophic
	Complexity	Many different allowable stresses on cables, specialty contractors required
	Error	Slight margin for error, must retain prescribed height of tendon through pour.
	Equipment	Extra jacking equipment needed
	Slab Curing	More time is needed between pours to stress tendons and allow relaxation
	MEP Coordination	MEP penetrations must be planned and fabricated beforehand. Few core-drills allowed.
	Onsite laydown area	Large space, cables must be unraveled prior to setting them in place
	Labor	Must have experienced subcontractor and personnel
	Mistakes	Most problems relating to reinforcement in slabs require large-scale removal of concrete/reinforcing
	Weather	Cannot be performed in less than 45 deg. F. without slab heaters

## Study of Alternate Floor Systems



# Charles

# Commons

Through discussions with the structural design firm, the existing floor system was found adequate. This shows that a live load of 125 psf and dead loads of 108 psf should be applied to alternate systems to compare the design inefficiencies. The three alternate systems I will analyze are the following:

- *Flat-plate reinforced concrete slab without drop panels*
- *Slab with one-way reinforced concrete beams with drop panels*
- *Precast concrete slab on cast-in-place beams*

*Alternate I: Flat-plate reinforced concrete slab without drop panels*

The flat-plate reinforced concrete slab idea was mentioned first by the general contractor on Charles Commons, Struever Bros, Eccles & Rouse. The foremost difficulty of post-tensioning is planning. The sequencing of trades before the slab pours proved much too difficult on the first four floors. In addition, slow-starting MEP Coordination could not effectively provide the dimensions in which slab penetrations would be needed. Since the first four structural slabs of St. Paul lie on the critical path of Charles Commons, it was no surprise that the overall project delayed more than three months.

The design of the flat-plate slab assumed all of the columns to be exactly where they had been designed. Only the flexibility of a flat-plate slab can allow the unequal spacing of columns and large openings. To move the column spacing to make the flat-plate slab design more efficient would have greatly compromised the architectural aspects of all of the floors of the building.

## *Methodology*

For this exercise, a 29' span between two columns was analyzed using the current codes on a spreadsheet. From this data, a trial slab thickness was found and input into E-TABS, a program that make calculations for various load combinations to extricate the forces and moments associated with the entire building. This model includes all openings, columns, beams, shear walls, and cladding.

## *Calculations*

The initial limiting factor for flat-plate slabs with 29' spans is the ACI limits on slab thickness. For a flat-plate design, the slab thickness is restricted by ACI (9.5.3.2) to be  $l_n/33$  without drop panels.

$l_{max} = 29' \Rightarrow \text{thickness} = (29' * 12) / 33 = 10.54'' > 8''$  existing slab thickness



# Charles

# Commons

It is quite doubtful that the designed slab without post-tensioning will be in the vicinity of 10" thick. It is most likely that the slab will be approximately 12-16" thick, so this limit factor does not limit this design.

At this point, the design was broken into interior and exterior spans to calculate the shear and moment capacities. As shown below, the design used 4000 psi concrete strengths and columns that are 24"x24". The total loads were calculated along with the allowable deflections. The following spreadsheet shows these values.

### INTERIOR SPANS

slab thickness:	<b>14 in</b>	column width:	<b>24 in</b>
f <sub>c</sub> :	<b>4000 psi</b>	column depth:	<b>24 in</b>
shear depth:	12.75 in	tributary width:	<b>29 ft</b>
		b for both strips:	14.5 ft
live load:	<b>125 psf</b>		
dead load:	<b>183 psf</b>	Longest clear span l <sub>n</sub> = 29 - (20/12) = 27.33 ft	
total unfactored load:	308 psf	Minimum h per ACI Table 9.5(c) = l <sub>n</sub> /33 = 10.54"	
total factored load:	<b>419.6 psf</b>		

V<sub>u1</sub> 4169.8 lb for a 12" width Allowable deflection for serviceability

$$L/240 = 1.45 \text{ in}$$

PhiV<sub>c</sub> 1329.9 lb  $L/360 = 0.97 \text{ in}$

$$L/480 = 0.725 \text{ in}$$

b<sub>o</sub> 147 in

Bars	Area	Unit weight
#4's	0.20	0.376
#5's	0.31	0.668
#6's	0.44	1.043
#7's	0.60	1.502
#8's	0.79	2.044
#9's	1	3.4

V<sub>u2</sub> 237.8 k

PhiV<sub>c</sub> 403029 lb

PhiV<sub>c</sub> 403.0 k

Static Moment o<sub>l</sub> 917.7 ft-k

Static Moment o<sub>s</sub> 917.7 ft-k



# Charles

# Commons

## EXTERIOR SPANS

slab thickness:	<b>14 in</b>	column width:	<b>24 in</b>
f'c:	<b>4000 psi</b>	column depth:	<b>24 in</b>
shear depth:	12.75 in	tributary width:	<b>29 ft</b>
		b for both strips:	14.5 ft
live load:	<b>125 psf</b>		
dead load:	<b>183 psf</b>	Longest clear span $l_n = 29 - (20/12) = 27.33$ ft	
total unfactored load:	308 psf	Minimum h per ACI Table 9.5(c) = $l_n/33 = 10.54$ "	
total factored load:	<b>419.6 psf</b>		

$V_{ur}$	4169.8 lb for a 12" width	Allowable deflection for serviceability
		$L/240 = 1.45$ in
$\Phi V_c$	1329.9 lb	$L/360 = 0.97$ in
		$L/480 = 0.725$ in

$b_o$	147 in
$V_{u2}$	237.75 k
$\Phi V_c$	403029 lb
$\Phi V_c$	403.03 k
Static Moment $o_l$	917.67 ft-k
Static Moment $o_s$	917.67 ft-k

Bars	Area	Unit weight
#4's	0.20	0.376
#5's	0.31	0.668
#6's	0.44	1.043
#7's	0.60	1.502
#8's	0.79	2.044
#9's	1	3.4

After the static moments in both directions are found, a chart is created using the moment equations for the column and middle strips depending on negative and positive moments from ACI 318 Section 8.3.3. These moments are checked for steel and the cross-section receives the selected bars.

For Interior Spans:

MOMENT CALCULATIONS	Span $o_l =$ Span $o_s$			
	Column Strip (12)		Middle Strip (12)	
	negative	positive	negative	positive
$M_u$	-481.8 ft-k	275.3 ft-k	160.6 ft-k	183.5 ft-k
$M_u / (\phi)(bd^2)$	-272.5 psi	155.7 psi	-90.8 psi	103.8 psi
$\rho$ (for 4000 psi)	0.0048	0.0033	0.0033	0.0033
$A_s$	10.649 in <sup>2</sup>	7.321 in <sup>2</sup>	7.321 in <sup>2</sup>	7.321 in <sup>2</sup>
Bars Selected	14 8's	10 8's	10 8's	10 8's





# Charles

# Commons

For Exterior Spans:

MOMENT CALCULATIONS	Span ol = Span os			
	Column Strip (lz)		Middle Strip (lz)	
	negative	positive	negative	positive
Mu	-206.5 ft-k	275.3 ft-k	68.8 ft-k	183.5 ft-k
Mu/(phi)(bd <sup>2</sup> )	-116.8 psi	155.7 psi	-38.9 psi	103.8 psi
rho (for 4000 psi)	0.0033	0.0033	0.0033	0.0034
As	7.321 in <sup>2</sup>	7.321 in <sup>2</sup>	7.321 in <sup>2</sup>	7.543 in <sup>2</sup>
Bars Needed	10 8's	10 8's	10 8's	10 8's

At the conclusion of the moment calculations, deflection calculations must be calculated since deflection will most likely limit the design of this slab. Three deflection calculations were made: dead load, live load, and total load. The equations used are found in ACI and are listed 9-8, 9-9, 9-10. These were compared to the allowable deflections specified by ACI 318, Table 9.5b. In addition, the long-term deflection (assumed greater than five years) ACI equation 9-11 was used and compared to the long-term limit of 1/240. Since the deflections for the exterior spans were found to be equal with the interior spans, there is only one chart posted.

DEFLECTION CALCULATIONS		
y	6.86 in	
Inertia	3319.06 in <sup>4</sup>	
Is	146.88 in <sup>4</sup>	
Live Mom	630750 ft-k	
Dead Mom	923418 ft-k	
rho'	0.040	Deflection Limits
Live Deflection	0.885 in	0.967 in
Dead Deflection	0.476 in	0.725 in
Total Deflection	1.361 in	1.450 in
Long-Term Deflec.	0.671 in	0.725 in

These deflection calculations caused what had amounted from an 11" slab to a 14" slab. Specifically, the live load and total load deflection limits control since the long spans and the 125 psf live load is not the most efficient use of concrete. If the spans were decreased 5' throughout Charles Commons and the dining hall function



# Charles

# Commons

removed, the slab would be controlled by the ACI span limits. The following is a cross-section of the designed 14" flat-plate slab.

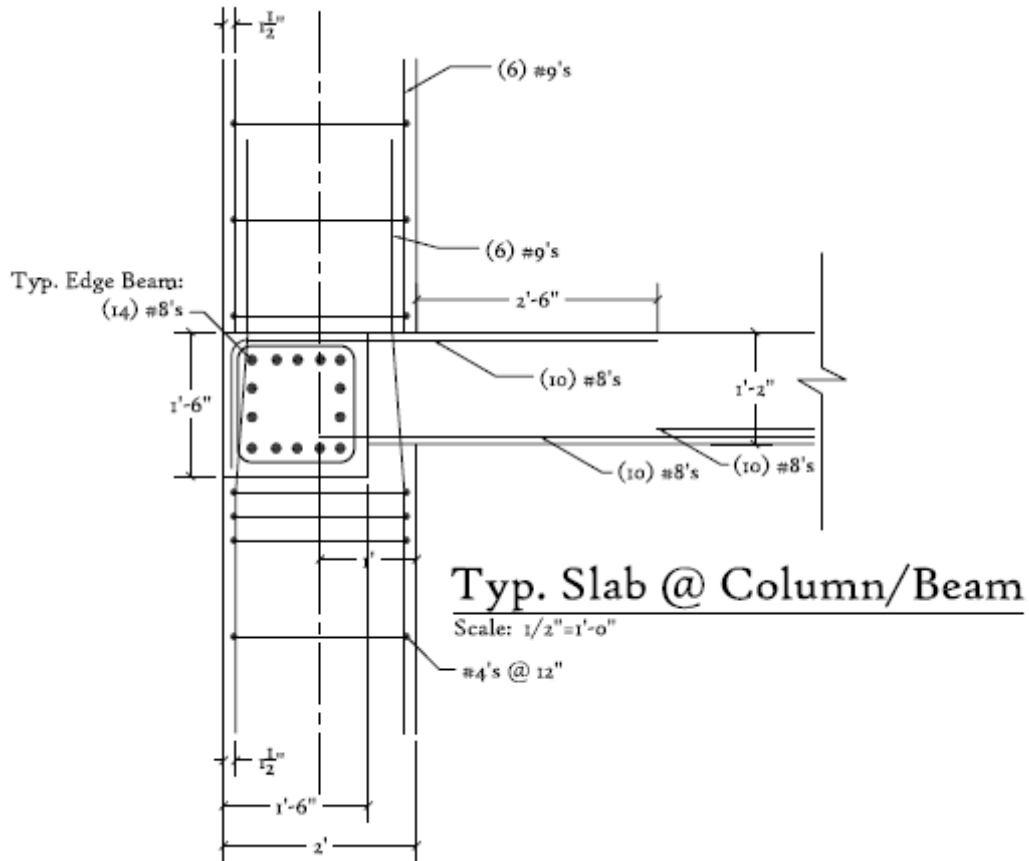



# Charles

# Commons

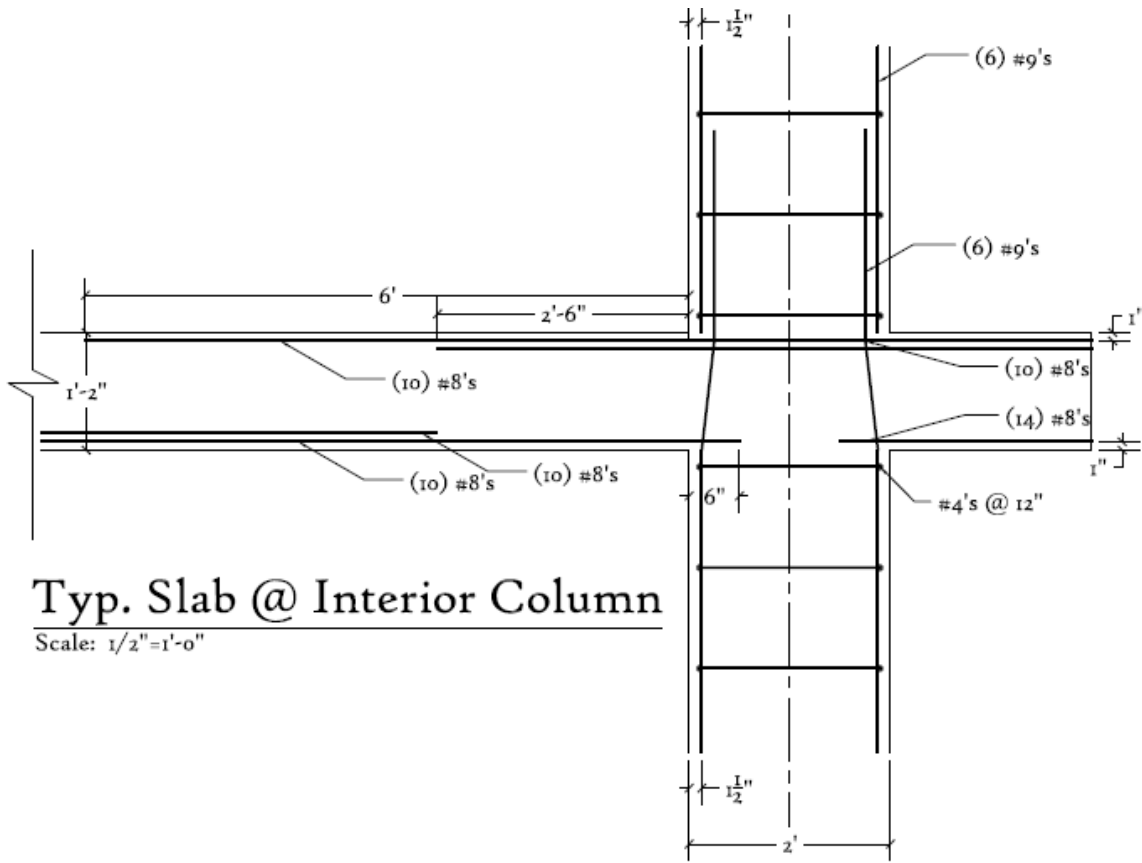

**Typ. Slab @ Interior Column**

Scale: 1/2" = 1'-0"



# Charles

# Commons



## Modeling

In addition to small-scale checks on a long-span of 29', E-TABS modeled six loads in different combinations and analyzed the following:

- Strength-required reinforcement
- Unbalanced moments due to uneven dead load (column spacing)
- Axial forces due to large live loads
- Point deflections due to a variety of loads

E-TABS was chosen over RAM and other software for its ability to model multiple customized floors that the moment and axial forces from the floors above could be distributed evenly over all slabs. RAM would have been useful for calculating finite element mesh analyses for the slabs, but approximately five different slabs would have to be modeled to adequately determine the design for all of the slabs in the ten floors of the St. Paul building.



# Charles

# Commons

## *Strength-required reinforcement*

The reinforcement required for the columns and beams were calculated based on load combinations of the loads: dead, live, super-imposed dead, cladding dead, wind, and earthquake. The beams were most affected by the 250 plf cladding dead loads while the columns were most affected by the 125 psf live loads. In addition, the largest loads were found to be on the perimeter of the building, where openings and uneven column spacing had controlled their design.

As an addendum to the original model, 18" x 18" columns replace the 24" x 24" columns on floors 5-10 to ensure efficient use of concrete. These changes are reflected in the following analyses.

## *Column design*

The interior columns on floors 1-4 were shown to require 5.76 sq. in. reinforcing for their 24" x 24" cross sections, which means approximately (6) #9 bars. The exterior columns on floors 1-4 are not as standard as the interior columns due to overloaded cross-sections in areas. Exterior columns are identical to the interior columns except:

- Column @ A<sub>1</sub>, at the southwest corner of the structure
- Column @ L<sub>1</sub>, near the southeast corner of the structure
- Column @ M<sub>1</sub>, at the southeast corner of the structure

At these columns, 36" x 36" cross-sections were used for the first two floors of these columns with 18 sq. in. of reinforcing, approximately (13) #11 bars. This overloading can be attributed to the large opening on the second floor level and the transfer of load from the recessed area on the south side of the building.

On floors 5-10, all of the columns are 18" x 18" and require 3.24 sq. in. of reinforcing, which is approximately (4) #9 bars. All columns including the columns on floors 5-10 have low requirements for shear reinforcing.

## *Beam design*

Only exterior beams are used in this design since they are implemented as edge beams. The typical beams were 18" x 18" and shown to require as much as 10.97 sq. in. longitudinal reinforcing. The shear and torsion reinforcing required was less than 1 sq. in. and made little impact on design. Typically (14) #8 bars were required for both the bottom and top longitudinal reinforcing. However, a few beams were exceptions such as the following:

- Beam spanning column line A, the first 4 floors, at the west elevation
- Beam spanning column line 1, the first floor, at the south elevation
- Beam spanning column line M, the first 4 floors, at the east elevation
- Beam spanning column line 2, floors 2-10, at the south recessed area





# Charles

# Commons

- The beams at column lines A and M are problem areas because of how the wind forces were applied to the model. The beam spanning column line I is an issue since it

braces a large cladding load and spans between the buildings largest columns. The beams spanning column line 2 are not in plane with the building's square footprint. All of these were deepened to 18"x22" and contain approximately the same reinforcing layout.

### *Unbalanced moments*

Diagrams were produced that show the unbalanced moments that are introduced due to the uneven loading residual from the column spacing. This diagram shows the largest moments where the cross-sections of the columns and beams were increased due to unbalanced conditions as mentioned in strength-required reinforcement. These diagrams can be found in Appendix B.

### *Axial forces*

As well as unbalanced moment diagrams, the resulting axial forces were compiled into a diagram. The over-sized beams and columns that resulted from the strength-required reinforcement show the greatest axial forces. These diagrams can be found in Appendix B as well.

### *Point Deflections*

Point deflections were calculated at random places along all of the slabs to find if the largest deflections meet the 0.725" limit for dead load and the 0.967" limit for live load. The largest deflections were found at the midpoints along the exterior of the building due to the cladding dead loads and at the midpoints of middle strips in the slab due to live loads. The deflection values ranged from 0 to -0.33", which is much less than both limits. This can be attributed to the fact that most of the 29' spans are along the exterior of the building where edge beams assist in deflection control and in areas where the transverse span is much less than 29', creating much smaller deflections.

Flat-Plate Slab	
Slab Thickness	14"
Concrete Strength	4000 psi
Slab Concrete Volume	9204 CY
Reinforcement Weight	Approx. 450 ton
Self-weight	175 psf



# Charles

# Commons

Building Height	139'-8"
Column Sizes	24"x24", 18"x18", and a few 36"x36"
Column Volume	748 CY

Flat-Plate Slab	Issue	Reason
Advantages	Safety	No special safety considerations
	Building Height Requirements	Relatively effective in areas with building height limits
	Complexity	Easy to duplicate construction, many contractors perform flat-plate
	Error	Larger margin for error, rebar only must maintain heights
	Equipment	No extra equipment needed
	MEP Coordination	MEP penetrations need not be planned beforehand. Core-drills are allowed on a limited spacing.
	Labor	Requires little subcontractor and personnel experience
	Mistakes	Most problems relating to reinforcement in slabs require minimal slab demolition that can be performed relatively easily
Disadvantages	Structural Code	Does limit slab thickness
	Rebar Placement	Needed in two directions
	Formwork	Requires more edge formwork for thicker slab
	Building Height Requirements	Little effectiveness in areas with building height limits
	Slab Curing	Time is needed between floors to allow for curing
	Onsite laydown area	Large space, different size rebar must be sorted prior to installation
	Weather	Cannot be performed in less than 45 deg. F. without slab heaters



# Charles

# Commons

## *Alternate II: Slab with one-way reinforced concrete beams and drop-caps*

The reinforced concrete slab with one-way reinforced concrete beams idea was mentioned first by Dr. Parfitt. This idea was changed approximately two weeks after this report was completed in mid-March to additional drop-caps when a live load deflection calculation mistake provided the savings of a 12" slab to a 9" slab. Drop-caps were added to prevent the punching shear that results from slabs smaller than 12" without drop-caps. This design would have approximately the same flexibility found with the flat plate slab, but using less concrete between the ribs of concrete joists. However, the column spacing must be altered to make the one-way beams span in perpendicular directions and will subsequently compromise the architectural aspects of all of the floors of the building. First, an adequate column layout must be found and modeled.

### *Adjusting the Column Layout*

Approximately half of the approximately 50-60 columns on each floor were adjusted as much as 12' to accommodate the one-way beam configuration. In addition, 17 columns were added creating smaller spans of 21' instead of 29'. However, the odd angled areas in the floor plan such as the loading dock, the grand staircase, and the lobby area will be left as a 10" slab. Approximately 25% more concrete will be used in the columns and 10% less concrete will be used in the slabs compared to the flat plate slab.

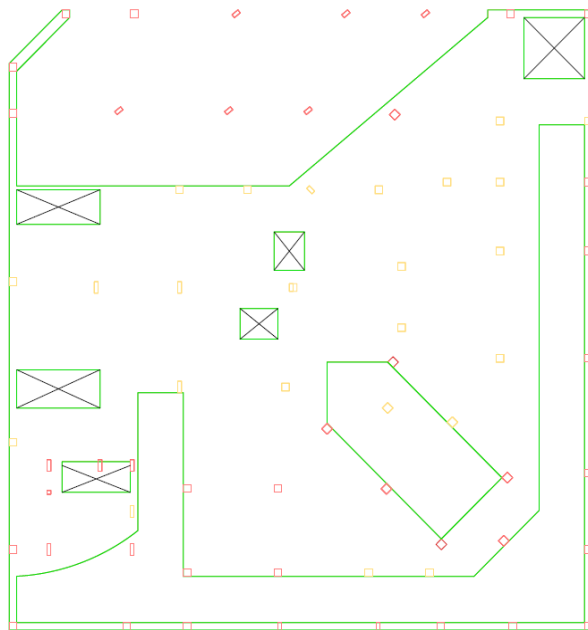

*Existing Column Layout  
(yellow columns are deleted)*

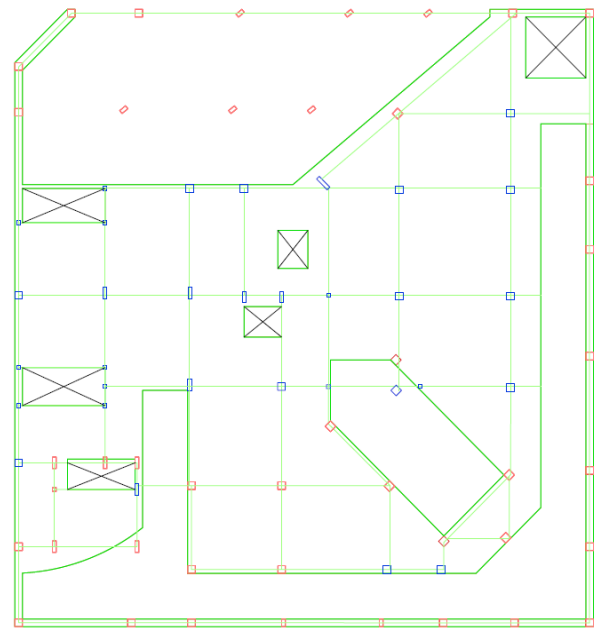

*Adjusted Column Layout  
(blue columns are added)*



# Charles

# Commons

## Architectural Adjustments

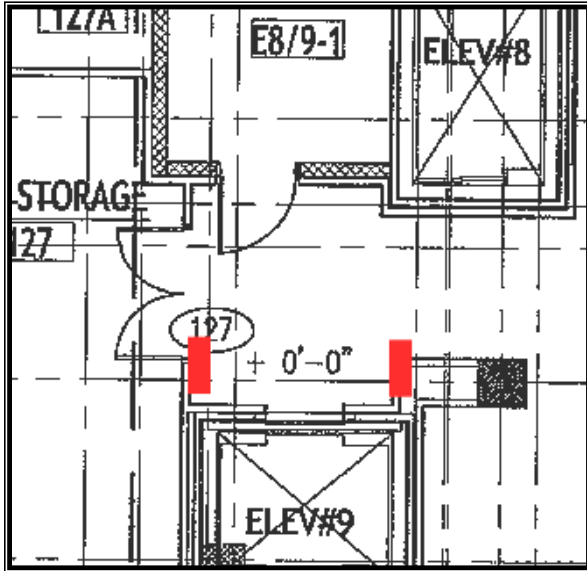

Second Floor, at elevator #9

In order to fit uniform bays around the openings on the second floor, a new column line was created running north to south along elevator #8 and #9. Another new column line ran along the west side of elevator #9. The conjunction of these new column lines lies in a storage corridor of the bookstore space. This arrangement impedes the opening of the doors into the storage room by 1', in which the doors must be adjusted 1' toward the north. Carts exiting elevator #9 should not have difficulty around the columns.

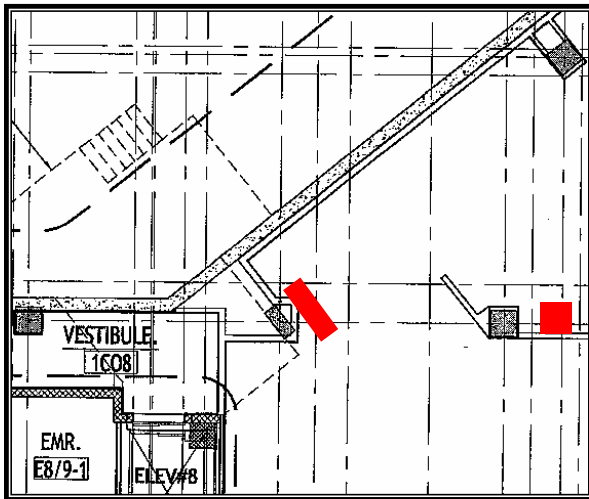

Second Floor, at the loading dock

In order to align the column lines next to the loading dock with those of the feature staircase, a service corridor near the loading docks needs to be adjusted 3' to the east. The full opening size is accounted for in this adjustment.

## Charles



## Commons

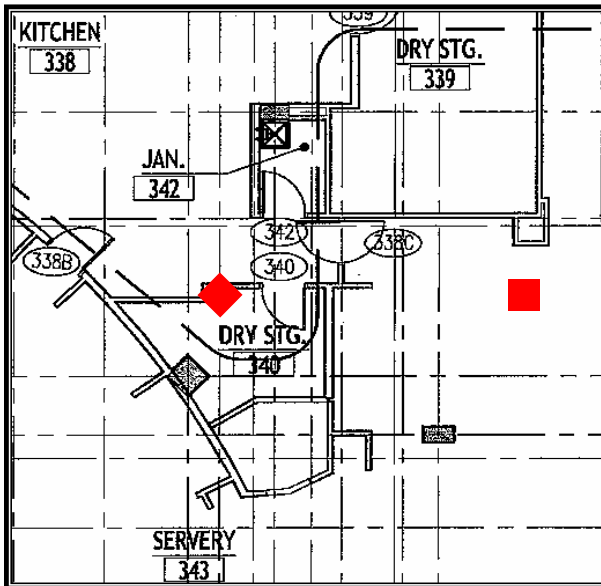

Third Floor, at the dining servery

All of the columns in the dining hall space have not been moved more than 2', except these in dry storage and a corridor beyond the servery. These were corrected by 5' to align the column lines from the dining hall to those near the conference room and loading docks. Both of these locations do not impede traffic through corridors or doorways.

### Methodology

For this exercise, a 21' span between two columns was analyzed using the current codes on a spreadsheet. From this data, a trial slab thickness and joist thickness was found and input into E-TABS. The model that tested this information was quite different from the model used for the flat plate slab. This model does not include openings, shear walls, and cladding. A 5x5 column configuration spanning 21' in each direction was duplicated for 10 stories to model this alternate because E-TABS cannot place any beams that aren't perfectly perpendicular or perfectly even opening sizes.

### Calculations

The initial limiting factor for one-way beams with 21' spans is the ACI limits on slab thickness. For a one-way beam design, the slab thickness is restricted by ACI (9.5.2.1) to be  $l_n/28$  for both end continuous spans.

$$L_{max} = 21' \Rightarrow \text{thickness} = (21' * 12) / 28 = 9" > 8" \text{ existing slab thickness}$$

Although 9" is much less limiting than the flat plate's 10.54", the overall design is still controlled by the deflections (the additional punching shear has already been remedied with 5'x5' drop panels). At this point, calculations were performed to find the moments at three locations and shear checks. As shown below, the design used 4000 psi concrete strengths and columns that are 24"x24". The total loads were





## Charles

## Commons

calculated along with the allowable deflections. The following spreadsheet shows these values.

### ONE-WAY SLAB WITH BEAMS AND DROP-CAPS

beam depth:	<b>14 in</b>	beam width:	<b>6 in</b>
slab thickness:	<b>9 in</b>	column width:	<b>24 in</b>
f <sub>c</sub> :	<b>4000 psi</b>	column depth:	<b>24 in</b>
shear depth:	7.75 in	first span:	21 ft
		second span:	21 ft
live load:	<b>125 psf</b>	b for both strips:	11 ft
dead load:	<b>132 psf</b>	Joists:	8 ea span or 30" clear spacing
total unfactored load:	257 psf		
total factored load:	<b>359 psf</b>	Longest clear span l <sub>n</sub> = 21 · (20/12) = 19.33 ft	
beam self-weight:	12 psf	Minimum h per ACI Table 9.5(a) = l <sub>n</sub> /28 = 9"	

at interior span:	17.59 ft·k	Allowable deflection for serviceability:
at midspan:	11.30 ft·k	L/240 = 1.05 in
at exterior support:	6.59 ft·k	L/360 = 0.53 in
		L/480 = 0.525 in

.75 ρ <sub>ob</sub>	0.02	
d <sup>2</sup>	18.79 in <sup>2</sup>	
d	4.33 in	
b <sub>o</sub>	8.26 in	
A <sub>s</sub>	0.50 in <sup>2</sup>	
a	0.74 in	
A <sub>s</sub>	0.49 in <sup>2</sup>	
A <sub>s</sub> at midspan:	0.32 in <sup>2</sup>	#5's @10" .37 in <sup>2</sup>
A <sub>s</sub> at exterior:	0.19 in <sup>2</sup>	#5's @15" .25 in <sup>2</sup>
A <sub>smin</sub>	0.19 in <sup>2</sup>	

V <sub>u</sub> :	4102 lb
V <sub>n</sub> = V <sub>c</sub> :	11764 lb
φV <sub>c</sub> :	9999 lb

Punching Shear for 24"x24" column, ACI 318 11.12.2.1

V <sub>c</sub>	4754 *smallest of three
V <sub>c</sub>	28291
V <sub>c</sub>	9055
V <sub>limit</sub>	11764 ok

Try 9" slab with 6"x14" beams @ 30"

Try 5'x5' drop-caps with 14" depth



# Charles

# Commons

After finding the reinforcement, deflection calculations must be calculated since deflection will most likely limit the design of this slab. Three deflection calculations were made: dead load, live load, and total load. The equations used are found in ACI and are listed 9-8, 9-9, 9-10. These were compared to the allowable deflections specified by ACI 318, Table 9.5a. In addition, the long-term deflection (assumed greater than five years) ACI equation 9-11 was used and compared to the long-term limit of  $l/240$ .

## DEFLECTION CALCULATIONS

Inertia	771 in <sup>4</sup>	
y	3.88 in	
I <sub>s</sub>	19 in <sup>4</sup>	
Total Inertia	790 in <sup>4</sup>	
x	114000	
Moment	50069 ft-k	Deflection Limits
Live deflection	0.608 in	0.7 in
Dead deflection	0.405 in	0.53 in
Total deflection	1.013 in	1.05 in
Long-term deflection	0.668 in	0.70 in



# Charles

# Commons

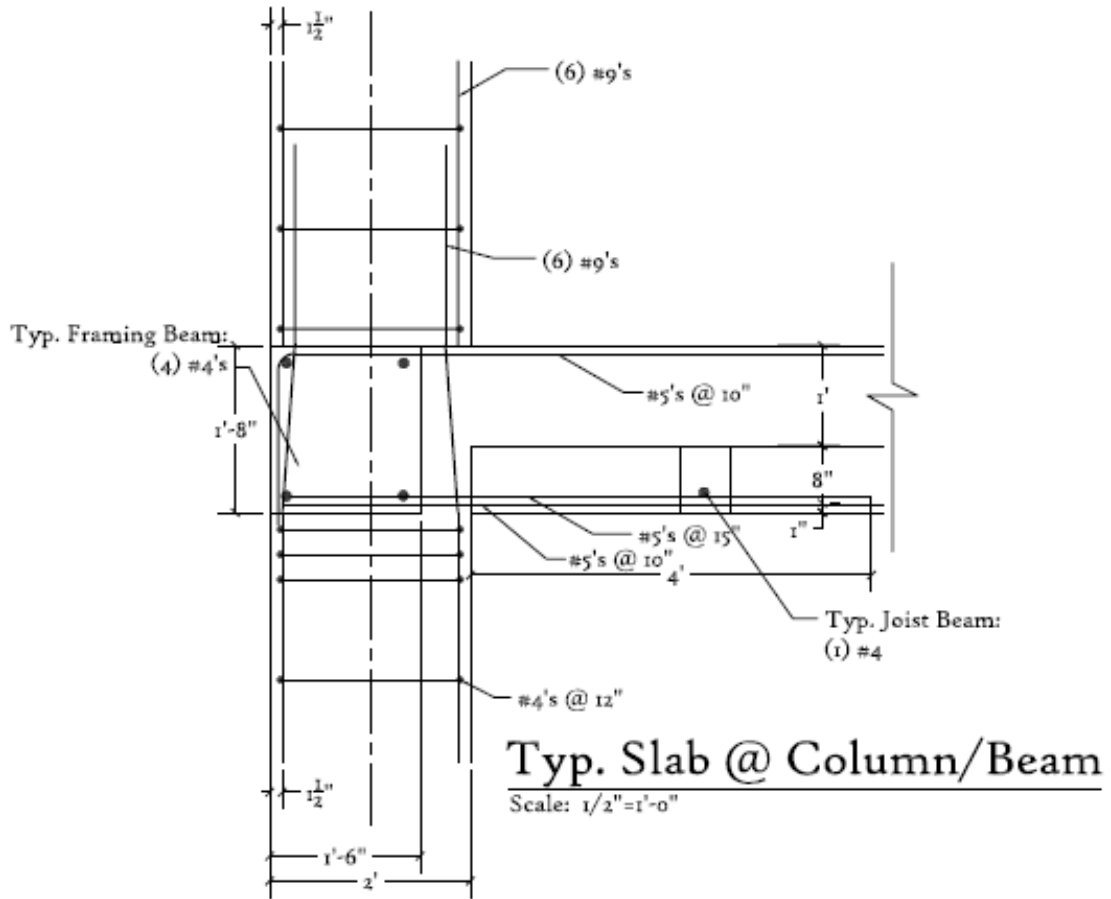



# Charles

# Commons

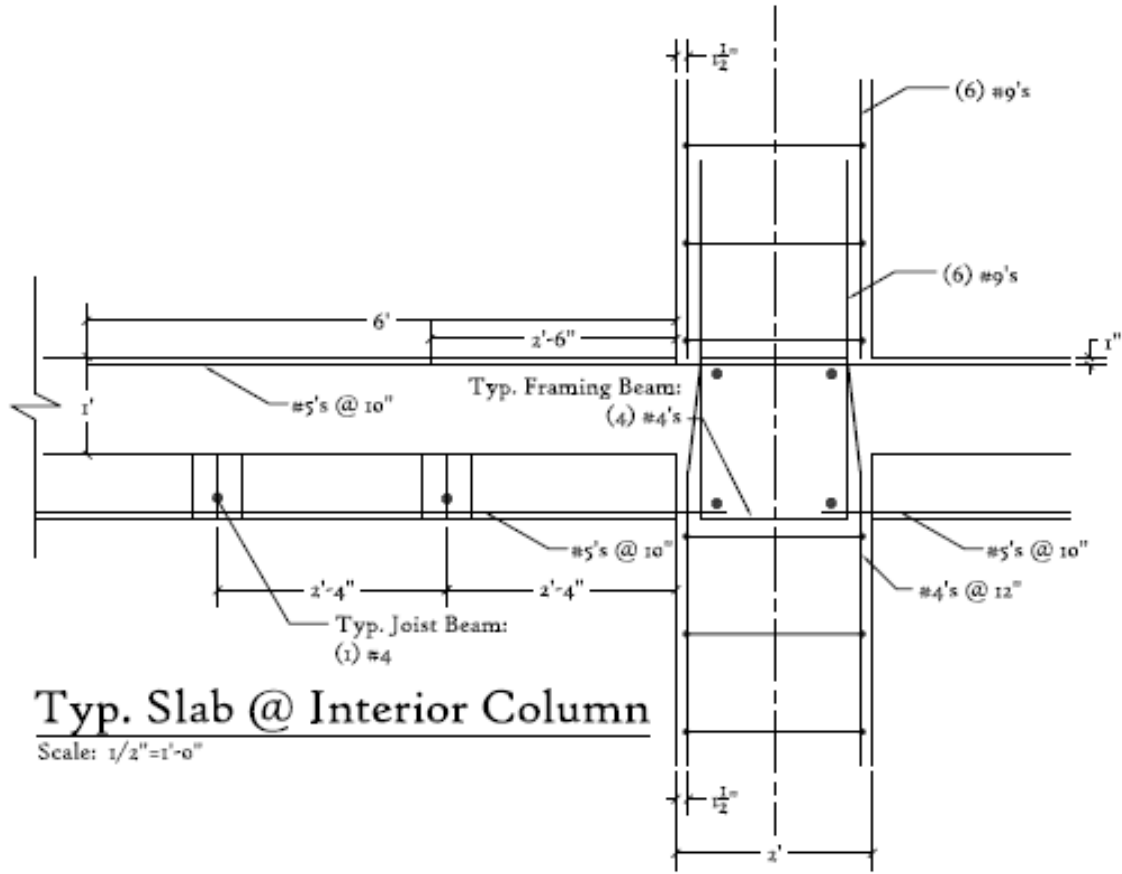



# Charles

# Commons

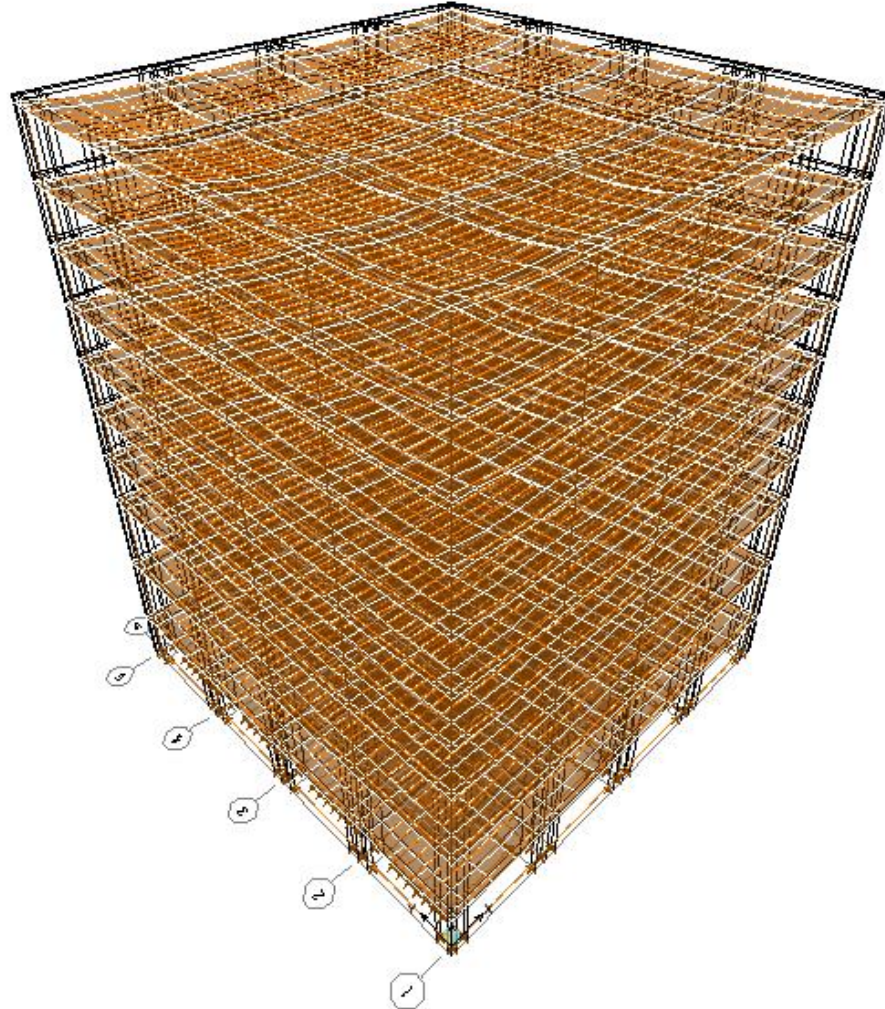

## *Modeling*

In addition to small-scale checks on a long-span of 21', E-TABS modeled six loads in different combinations and analyzed the following:

- Strength-required reinforcement
- Axial forces due to large live loads
- Point deflection due to a variety of loads

Although E-TABS is the best for this application, E-TABS does not allow beams to span outside of the initially specified grid. Therefore, a highly idealized model of the St. Paul building's new column layout must be used.

## *Strength-required reinforcement*





# Charles

# Commons

The reinforcement required for the columns and beams were calculated based on load combinations of the loads: dead, live, super-imposed dead, and cladding dead

load. Consideration of wind and earthquake loads were omitted since this “ideal” condition does not realistically compensate for the differences in the exterior shape of the building (including the courtyard). The beams were most affected by the 250 plf cladding dead loads while the columns were most affected by the 125 psf live loads.

As an addendum to the original model, 18”x18” columns replace the 24”x24” columns on floors 5-10 to ensure efficient use of concrete. These changes are reflected in the following analyses.

## *Column design*

The columns on floors 1-4 were shown to require 5.76 sq. in. reinforcing for their 24”x24” cross sections, which means approximately (6) #9 bars. All other columns require 4.27 sq. in. reinforcing for their 18”x18” cross sections. These results show that the one-way slab alternative is quite capable of holding the 125 psf live load under 21’ spans.

## *Beam design*

Two types of beams are used in this design: joist beams and framing beams. The framing beams were 12”x14” and shown to require as little as 0.7 sq. in. (or four #4’s) longitudinal reinforcing. The shear and torsion reinforcing required was less than 1 sq. in. and made little impact on design. The joist beams were much smaller, where typically eight joists span 21’ and have 6”x14” dimensions (or 28” clear spacing). These joist beams only require 0.15 sq. in! Each joist only requires one #4 bar.

## *Axial forces*

The resulting axial forces were compiled into a diagram. The under-sized beams and columns that resulted from the strength-required reinforcement show the least axial forces are located at the top of the building. These diagrams can be found in Appendix B.

## *Point Deflections*

Point deflections were calculated at random places along all of the slabs to find if the largest deflections meet the 0.700” limit for live load. The largest deflections were found at the midpoints along the exterior of the building. The highest deflection values were 0.455” for live load, which is comfortably below the limits.



# Charles

# Commons

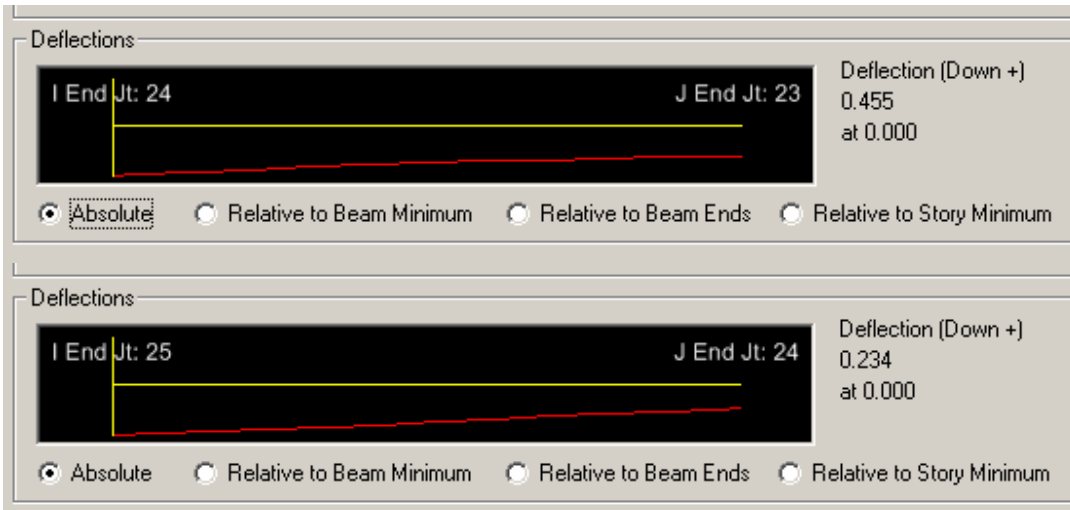

One-way Beams with Drop-caps	
Slab Thickness	9" with 14" drop-caps
Concrete Strength	4000 psi
Slab Concrete Volume	6518 CY
Reinforcement Weight	Approx. 500 ton
Self-weight	160 psf
Building Height	138'-0"
Column Sizes	24"x24", 18"x18", 12"x24"
Column Volume	948 CY

One-way Beams	Issue	Reason
Advantages	Safety	No special safety considerations
	Complexity	Easy to duplicate construction, many contractors perform one-way beam structures
	Error	Larger margin for error, rebar only must maintain heights
	Equipment	No extra equipment needed
	MEP Coordination	MEP penetrations need not be planned beforehand. Core-drills are allowed on a limited spacing.
	Labor	Requires little subcontractor and personnel experience
	Mistakes	Most problems relating to reinforcement in slabs require minimal slab demolition that can be performed relatively easily
	Building Height	Effective in areas with building height limits



# Charles

# Commons

Disadvantages	Structural Code	Does limit slab thickness greatly
	Rebar Placement	Needed in two directions, but separate in beams and slab
	Formwork	Requires more edge formwork for thicker slab and formwork for added beams
	Slab Curing	Time is needed between floors to allow for curing
	Onsite laydown area	Large space, different size rebar must be sorted prior to installation
	Weather	Cannot be performed in less than 45 deg. F. without slab heaters

### *Alternate III: Precast planks on cast-in-place beams*

The precast plank idea was first developed when schedule problems began occurring on Charles Commons. This design would have limited flexibility as in post-tensioned slab, but by using less reinforcement. The column spacing will be identical to that of the one-way beam design in which all beams span in perpendicular directions, compromising the architectural aspects of all of the floors of the building.

### *Methodology*

For this exercise, a 21' span between two columns was analyzed using the current codes on a spreadsheet. From this data, a trial plank thickness and beam thickness was found and input into E-TABS. Again, a 5x5 column configuration spanning 21' in each direction was duplicated for 10 stories to model this alternate because E-TABS cannot place any beams that aren't perfectly perpendicular or perfectly even opening sizes.

### *Calculations*

Sizing precast plank is customarily reserved for the manufacturer. Despite this limitation, simple axial load calculations were made and the applicable hollow core plank is Nitterhouse Concrete Products' 8"x4' SpanDeck U.L. J917, 6-strand model. Application of this product requires a 2" concrete topping. Since the



# Charles

# Commons

specification for this product used allowable superimposed load instead of factored loads, I have included a 2.16 factor of safety at this capacity. The precast planks will be set on top of cast-in-place beams and columns that will be fluted to allow for the precast bearing.

## PRECAST PLANK & BEAMS

beam depth:	<b>16 in</b>	beam width:	<b>24 in</b>
slab thickness:	<b>8 in</b>	column width:	<b>24 in</b>
f <sub>c</sub> :	<b>5000 psi</b>	column depth:	<b>24 in</b>
shear depth:	6.75 in	tributary width:	21 ft
span:	21 ft	b for both strips:	10.5 ft
live load:	125 psf		
dead load:	8 psf		

total factored load:	308.6 psf	Nitterhouse Concrete Products
allowable superimp:	<b>287 psf</b>	UL J917 8" x 4' SpanDeck, 6 strand
calculated superimp:	<b>133 psf</b>	plus 2" CIP topping
F.S.:	<b>2.16</b>	

<i>weight of precast:</i>	330 plf
<i>precast self weight:</i>	82.5 psf
<i>flat plate self weight:</i>	175 psf
<i>one-way beam weight:</i>	132.4 psf



# Charles

# Commons

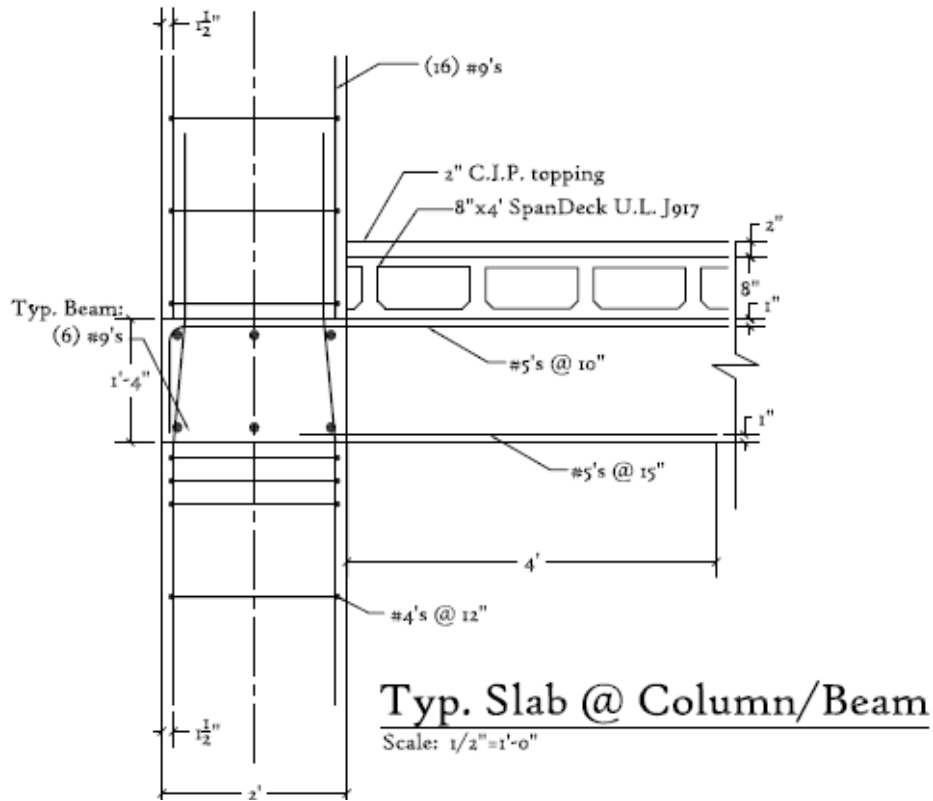





# Charles

# Commons

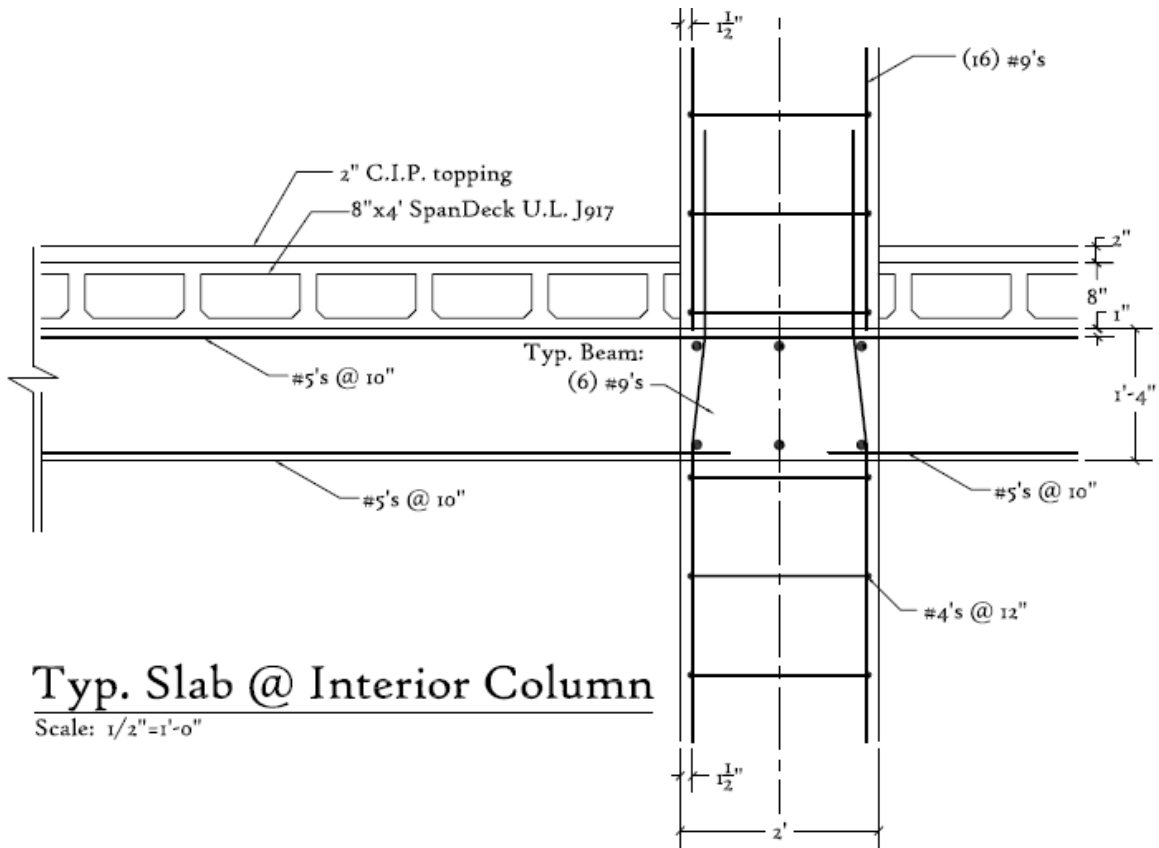

**Typ. Slab @ Interior Column**

Scale: 1/2"=1'-0"





# Charles

# Commons

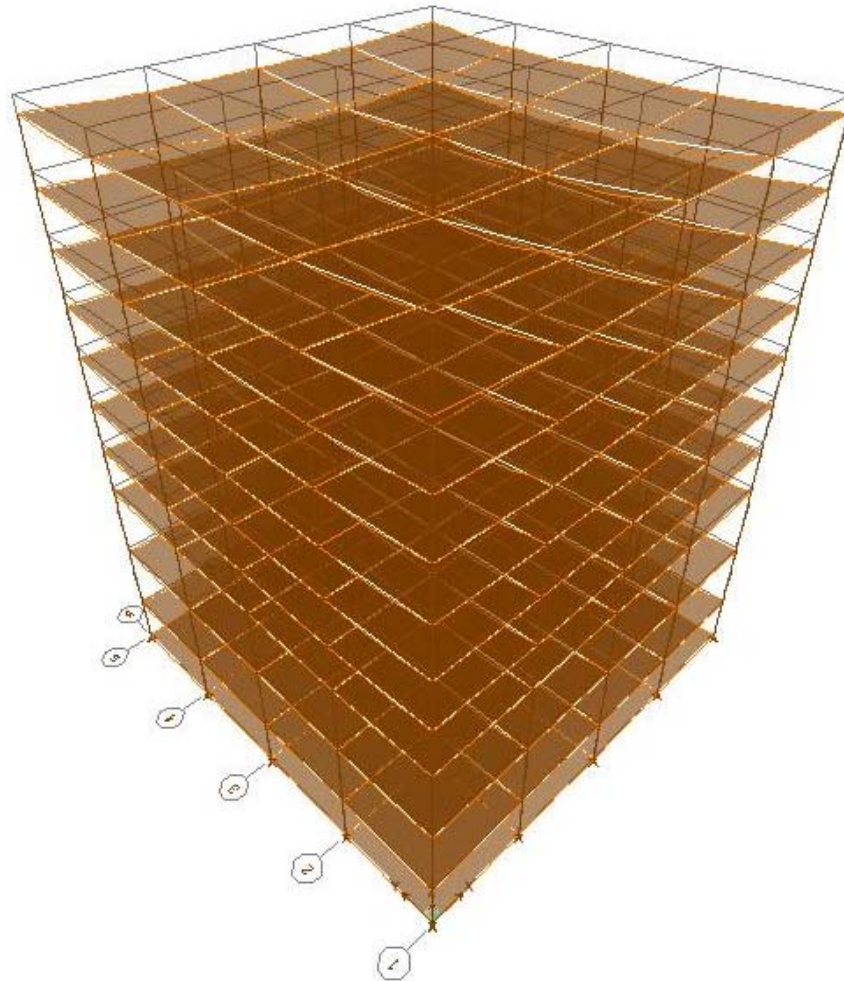

## *Modeling*

In addition to small-scale checks on a long-span of 21', E-TABS modeled six loads in different combinations and analyzed the following:

- Strength-required reinforcement
- Axial forces due to large live loads
- Point deflection investigation for beams

## *Strength-required reinforcement*

The reinforcement required for the columns and beams were calculated based on load combinations of the loads: dead, live, super-imposed dead, and cladding dead load. Consideration of wind and earthquake loads were omitted since this “ideal” condition does not realistically compensate for the differences in the exterior shape of the building (including the courtyard). The beams and the columns were most



# Charles

# Commons

affected by the 125 psf live loads. In addition, the largest loads were found to be on the interior of the building, which is the opposite of the convention of large exterior loads

found in the models of the flat plate slab and one-way beams. This can only be explained by the pinned nature of the precast planks and the large live load being transferred to the interior columns instead.

## *Column design*

The columns along the exterior of the building and the higher floors of the building were sized as 18" x 18" with steel areas averaging 5.76 sq. in. Six #9 bars are specified for these columns. As shown in Appendix B, center sections were taken to display the larger interior columns. The interior columns on the first five floors for the entire structure are sized as 24" x 24" and 28" x 28"; the larger of which is closest to the center and grade level in the building. The 24" x 24" columns require 16 sq. in. of reinforcing (or 16 #9's) and the 28" x 28" columns require 30 sq. in. of reinforcing (or 20 #11's). Since no moment transfers in pinned connections of the precast hollow-core plank, the exterior of the building is relieved from the moment transfer experienced in the previous two models.

## *Beam design*

The beams are quite unlike the columns in this design. The capacity attained with a 24" x 16" beam specified in the previous spreadsheet was plenty for the precast plank. I attribute this to the large width of the beam and the lighter hollow-core precast planks. These beams require up to 5.73 sq. in. of reinforcing which amounts to 6 #9's. No substantial torsion or shear reinforcing was specified by the model since the earthquake and wind loads were not considered in this model.

## *Axial forces*

The resulting axial forces were compiled into a diagram. The over-sized columns that resulted from the strength-required reinforcement show the greatest axial forces from the transfer of moment directly to the columns. These diagrams can be found in Appendix B as well.

## *Point Deflections*

Point deflections were not calculated for the precast alternative prior. Despite this, I believe that it would still be prudent to show the maximum deflections for live and dead loads for the beams. Live load deflection is 0.235" and dead load deflections reach 0.332". The values are the opposite from the findings for the one-way beams in



# Charles

# Commons

which the live load deflection was larger as calculated. It is unknown for which this may have occurred since the live load remains at 125 psf.

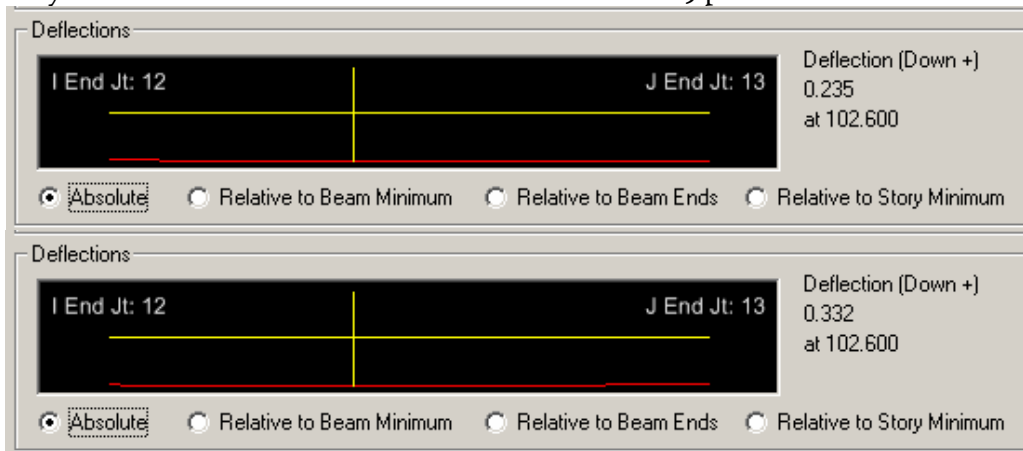

## Precast Beams and Columns

Precast beams and columns instead of cast-in-place beams and columns were not considered as an alternative structural system for a few very important reasons. First, the tolerance needed to install precast columns and beams so that they can accept the precast hollow-core planks without resorting to “making it work” or re-ordering the piece is very critical. Since many of the caissons were constructed in the wrong places on Charles building, the chance of losing time is always looming. Secondly, the site is quite small, allowing only for on-time delivery of the precast hollow-core planks. The addition of beams or columns can over-congest the site and require both cranes for the entire project. Also, the lengths of the columns can become too much for the delivery trucks to maneuver in downtown Baltimore. Finally, permits were refused by the City of Baltimore for temporary lane closures, which would undoubtedly be required for such an influx of deliveries.

Precast plank	
Slab Thickness	8" (2" topping)
Concrete Strength	5000 psi
Slab Concrete Volume	0 CY (all precast)
Reinforcement Weight	None, strands in planks
Self-weight	82.5 psf
Building Height	136'-4"
Column Sizes	24" x 24", 18" x 18", 12" x 24"
Column Volume	948 CY





# Charles

# Commons

Precast plank	Issue	Reason
Advantages	Safety	No special safety considerations
	Complexity	Not difficult to duplicate construction, many contractors perform precast plank structures
	Weather	Can easily be performed in less than 45 deg. F. (with the exception of the cast-in-place columns and beams)
	Equipment	No extra equipment needed
	Structural Code	Does not limit slab thickness
	Rebar Placement	Only in the cast-in-place beams
	Slab Curing	Curing time is only needed for the cast-in-place beams
	Formwork	Requires no edge formwork, only formwork for beams
	Onsite laydown area	On-time delivery is needed for precast beams
	Building Height Requirements	Quite effective in areas with building height limits
Disadvantages	Error	Minimal margin for error, planks must meet tolerance
	MEP Coordination	MEP penetrations need to be planned beforehand. Small core-drills are allowed.
	Labor	Requires subcontractor and personnel experience
	Mistakes	Most problems relating to the precast planks require removal and recasting of whole plank sections



## Charles

## Commons

## Constructability Review Summary

The previous four tables that describe the fourteen issues that affect each system were compiled into the following table. Each positive outcome to an issue is **green**, each fair outcome is **yellow**, and poor outcomes are shown in **red**. As expected, the less complex alternative systems are easier to construct than post-tensioned systems. The main problem with this analysis is its inability to quantify these issues into tangible cost and schedule impacts. If these issues could be quantified, it would be obvious that each alternative system saves over the existing post-tensioned system.

Issue	Post-Tensioning	Flat-Plate	One-Way Beams	Precast Plank
Safety	Red	Green	Green	Green
Complexity	Red	Green	Green	Yellow
Weather	Red	Red	Red	Yellow
Equipment	Red	Green	Green	Green
Structural Code	Green	Red	Red	Green
Rebar Placement	Red	Yellow	Yellow	Green
Slab Curing	Red	Yellow	Yellow	Green
Formwork	Yellow	Yellow	Red	Green
Onsite Laydown Area	Yellow	Yellow	Yellow	Red
Building Height	Green	Yellow	Yellow	Green
Error	Red	Green	Green	Red
MEP Coordination	Red	Green	Green	Yellow
Labor	Red	Green	Green	Yellow
Mistakes	Red	Green	Green	Red

# Charles



# Commons

## *Schedule Reduction*

The impact of these different concrete structural systems to the sequencing of Charles Commons is not a very big issue. Since all of these systems incorporate the same (or slightly larger) cast-in-place foundation, columns, and edge beams into their construction, essentially all of the sequencing issues lie with the construction of the slab (or additional beams). The on-time delivery of precast planks can be handled by the dual tower cranes onsite since there is less reinforcing to handle onsite. The one-way beams and flat plate slab requires more reinforcing and concrete, but they do not need post-tensioning cables stored onsite. All of the alternatives have small sequencing issues related, but these issues are not comparable to the issues experienced with post-tensioning.

The structure of St. Paul is on the critical path of the project and any schedule savings found here can help the project get back on track. These alternative systems also have design and coordination schedule savings, however, these are difficult or impossible to consider from a structural stand-point. Later in this thesis report, the time allocated for MEP Coordination will be analyzed for each of these structural alternates.

The following schedule shows how long it takes to complete the first three floor slabs as compared to the three months taken to complete the post-tensioned slabs. It is assumed that the concrete contractor will man the job similarly with all alternative systems. The standard work week in this exercise is 16 hours a day, 7 days a week. Approximately 180 men are present on each shift for the concrete contractor. Productivity losses associated with approximately 12 crews and 180 men are assumed to be 25%, or the shift's total production amounts to 135 men. Also, a 14% increase in labor is assumed for the one-and-a-half overtime work completed over the weekends. Since there is a learning-curve associated with concrete construction, the first floor is adjusted to take 150% longer than what has been calculated.

The schedule calculates the length of all of the activities if they were completed one-after-another. Some overlapping will occur with these activities, but estimating this is purely academic. The savings on this 3-floor schedule is broken into an individual floor savings and multiplied by ten to represent the savings over the entire St. Paul structure. This savings is shown on the cost estimate to calculate the reduced general conditions.

# Charles



# Commons

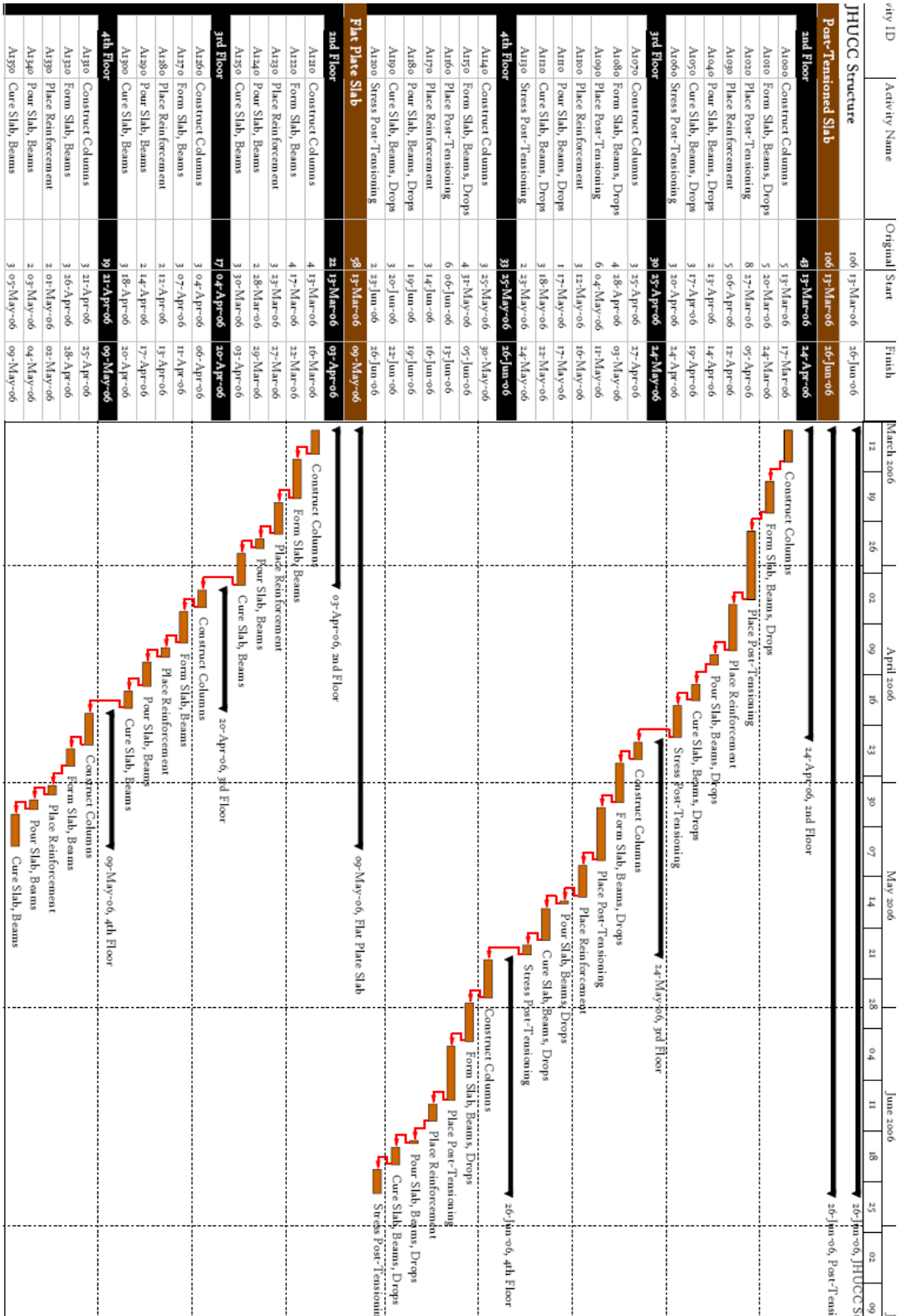

# Charles



# Commons

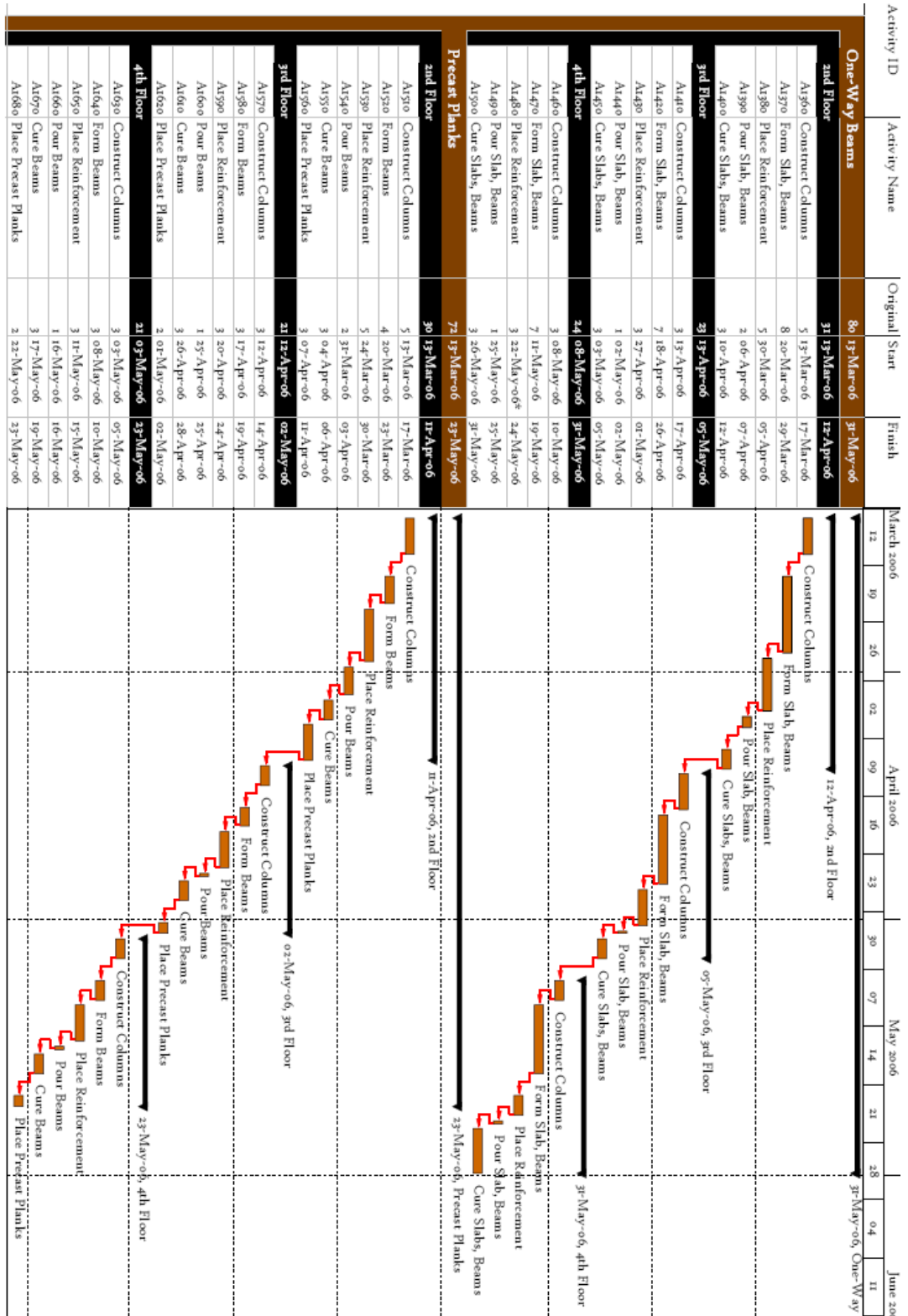





## Charles

## Commons

## Value Engineering

## EXISTING POST-TENSIONING

	Estimate	Projected	Bid	Total Building:	\$54,310,854
<i>Foundation</i>				Total St. Paul:	\$35,845,164
Drilled Caissons	\$471,916	\$589,895	\$471,916	St. Paul per/ft heig	\$266,177
Caisson Caps	\$33,116	\$33,116	\$33,116	Floors 1-4 Schedule	106 days
Grade Beams	\$35,626	\$35,626	\$35,626	General Conditions	\$4,660,184
Footings	\$49,649	\$49,649	\$49,649	16 month schedule	
Foundation Total:	\$590,307	\$708,286	\$590,307	Gen Cond/month:	\$291,262
<i>Superstructure</i>					
Concrete Columns	\$3,047,695	\$3,868,186	\$2,536,298		
Concrete Beams	\$324,555	\$324,555	\$324,555		
Shearwalls	\$471,458	\$471,458	\$471,458		
Concrete Slabs	\$3,845,175	\$4,421,951	\$3,359,948		
Superstructure Total:	\$8,227,105	\$9,086,151	\$6,692,259		
Subtotal:	\$8,817,412	\$9,794,437	\$7,282,566		
Location Factor of 92.7					
10% Markup	\$8,991,115	\$9,987,387	\$7,426,033		
Coordination Allowance	\$287,220	\$350,000	\$287,220		
Historical Cost Index	\$8,424,728	\$9,386,348			
Total:	<b>\$8,711,948</b>	<b>\$9,736,348</b>	<b>\$7,713,253</b>		
	<b>1106</b>	<b>2106</b>			

## ALT 1 FLAT PLATE

	Estimate	Assumptions	Added Height:	5 ft
<i>Foundation</i>			Added Height Cost	\$1,330,884
Drilled Caissons	\$519,108	10% increase	Floors 1-4 Schedule	58 days
Caisson Caps	\$36,427	10% increase	Schedule Savings:	3.5 mo
Grade Beams	\$39,189	10% increase	Gen Cond Savings:	\$1,019,415
Footings	\$54,614	10% increase		
Foundation Total:	\$649,338	increase due to more weight		
<i>Superstructure</i>				
Concrete Columns	\$2,953,637	add sizes, deduct strength	Systems Difference	\$311,469
Concrete Beams	\$331,046	added beam sizes		
Shearwalls	\$471,458	same		
Concrete Slabs	\$3,406,986	added concrete, formwork, rebar and deduct strength, PT		
Superstructure Total:	\$7,664,546			
Subtotal:	\$8,313,884			
Location Factor of 92.7				
10% Markup	\$8,477,668			
Coordination Allowance	\$0			
Systems Difference:	\$311,469			
Total:	<b>\$7,980,536</b>			
Difference:	<b>-\$731,412</b>		<b>-8.40%</b>	compared to PT estimate

## Charles



## Commons

**ALT 2 ONE-WAY BEAMS**

<i>Foundation</i>	Estimate Assumptions	Added Height:	3.333 ft
Drilled Caissons	\$519,108 10% increase	Added Height Cost	\$887,168
Caisson Caps	\$36,427 10% increase	Floors 1-4 Schedule	80 days
Grade Beams	\$39,189 10% increase	Schedule Savings:	2.0 mo
Footings	\$54,614 10% increase	Gen Cond Savings:	\$582,523
Foundation Total:	\$649,338 increase due to more weight		

*Superstructure*

Concrete Columns	\$3,252,089 add sizes, ded. strength		
Concrete Beams	\$692,046 add beams	Systems Difference	\$304,645
Shearwalls	\$471,458 same		
Concrete Slabs	\$3,174,611 added concrete, formwork, rebar and deduct strength, PT		
Superstructure Total:	\$8,121,519		

Subtotal: \$8,770,856

Location Factor of 92.7

10% Markup \$8,943,642

Coordination Allowance \$71,805

Systems Difference: \$304,645

Total: **\$8,462,643**~~\$249,305~~**-2.86%** compared to PT estimate**ALT 3 PRECAST PLANK**

<i>Foundation</i>	Estimate Assumptions	Added Height:	1.67 ft
Drilled Caissons	\$471,916 no increase	Added Height Cost	\$444,515
Caisson Caps	\$33,116 no increase	Floors 1-4 Schedule	72 days
Grade Beams	\$35,626 no increase	Schedule Savings:	2.2 mo
Footings	\$49,649 no increase	Gen Cond Savings:	\$640,775
Foundation Total:	\$590,307 no increase due to lightweight hollow plank		

*Superstructure*

Concrete Columns	\$3,260,746 add bearing, deduct weight		
Concrete Beams	\$795,853 add beam sizes	Systems Difference	-\$196,260
Shearwalls	\$471,458 same		
Concrete Slabs	\$3,207,696 precast planks		
Superstructure Total:	\$7,967,826		

Subtotal: \$8,558,133

Location Factor of 92.7

10% Markup \$8,726,728

Coordination Allowance \$287,220

Systems Difference: -\$196,260

Total: **\$8,006,461**~~\$705,488~~**-8.10%** compared to PT estimate



## Charles

## Commons

## Cost Comparison

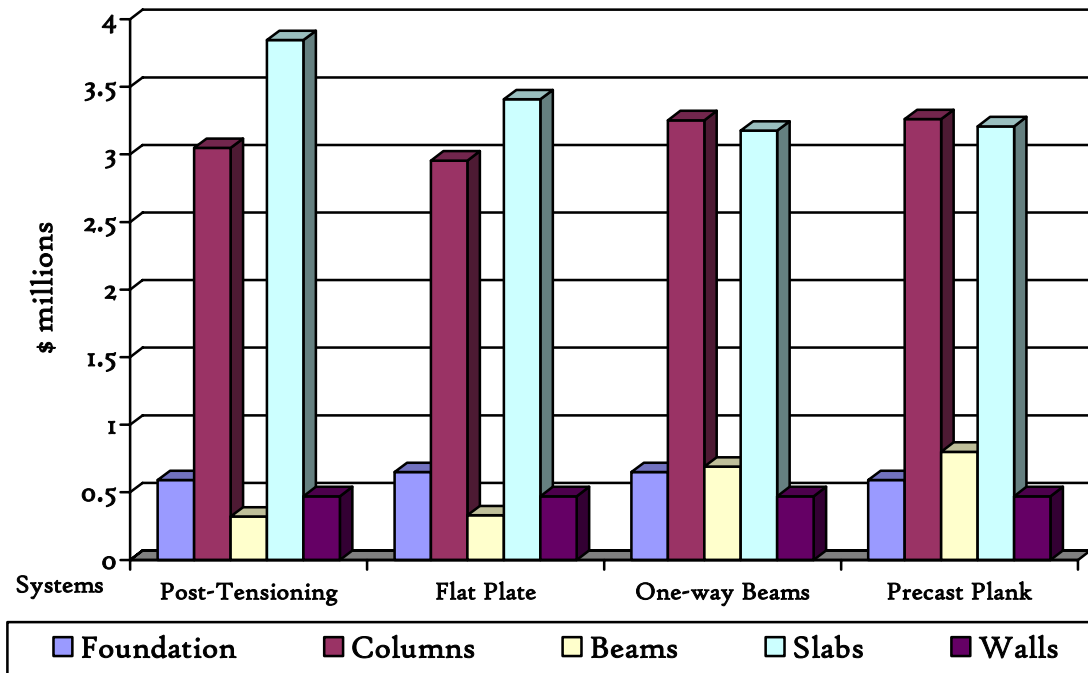

## Structural Conclusions

The redesign of the structural slabs for the St. Paul building is meant to find a system in which the project team has the most likely chance of success. After research in the ACI code, countless concrete books, and PCA online design examples, I made a spreadsheet for each system's design limit. Recommendations from these spreadsheets were fed into E-TABS, where models were created to check the reality of my calculations on the structure. Since axial forces and deflections were found to control the spreadsheet's output, these were used to design the slabs, beams, and columns for the St. Paul building.

Many different issues have been analyzed to make comparisons between the existing system and three alternatives. Quantitative analyses of the cost and schedule impacts show that the flat-plate slab and precast plank alternatives are the least expensive and take nearly  $\frac{1}{2}$  of the time required by the existing system. Qualitative analyses, such as the constructability review, were made for each system, in which all of the alternatives were found to be the best and the existing system was ranked worst. Therefore, the two best structural systems for this project from a structural standpoint are precast plank and flat-plate. Since these two systems are quite structurally comparable to each other, the limitations on the ceiling plenum will factor into the analysis.



*Charles*

*Commons*

**Mechanical Breadth:**  
MEP Coordination/Ductwork Rerouting

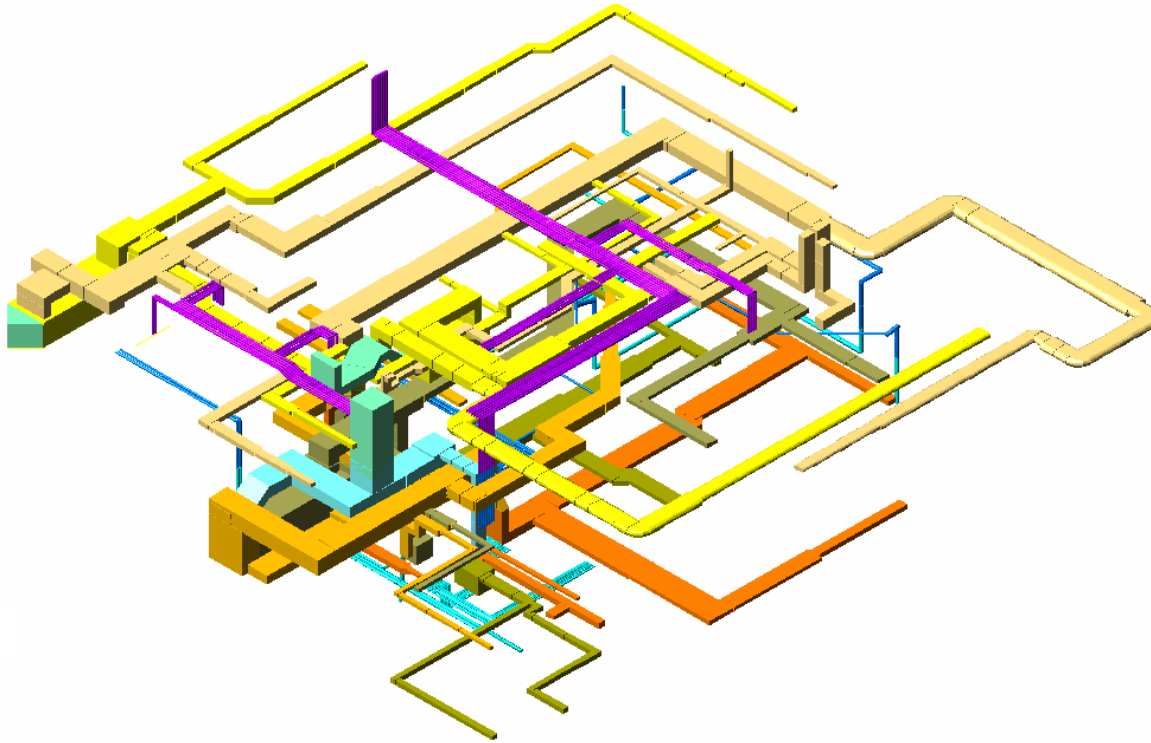

# Charles



# Commons

## *Background*

The design of structural slabs for the St. Paul building was completed to understand the impact of alternative structural systems to the bottom-line costs, the critical path, and the problems encountered onsite. Post-tensioned slabs have been shown to be inferior in all of these categories and have proven to be a real headache in the field at Charles Commons. However, the best way to analyze a design change is to measure its beneficial/negative effects on the other half of the building systems. Exterior skin, interior finish, mechanical ductwork, plumbing, fire protection, and electrical systems are all impacted by the structure. The MEP portion of the project is most affected by the structural slabs since the MEP runs adjacent to the slabs and therefore, the MEP coordination would be the most beneficial analysis.

In the interview with the owner's representative, Mike DiProspero, the problems with the existing MEP coordination were discussed. First, the MEP coordination started late. MEP coordination has been assumed to be optimal when beginning during MEP design to prevent designing the systems twice, as learned on the UW Research & Technology building in the interview with John Whitlow. On Charles Commons, MEP coordination began after design was completed and subcontractors were awarded contracts.

Secondly, the MEP coordination suffered from a lack of direction on the part of its participants. Initially, MEP coordination was the task of the mechanical/electrical engineer. When submittals were completed, they would be used to coordinate the environmental systems. Problems in obtaining submittals and cooperation delays caused more of the MEP coordination to be completed in the field. Thus, a MEP superintendent was brought on-board late in the process in the attempt to salvage the coordination. Later in the project, the ceiling heights were lowered one foot in all of the St. Paul building spaces anyway.





# Charles

# Commons

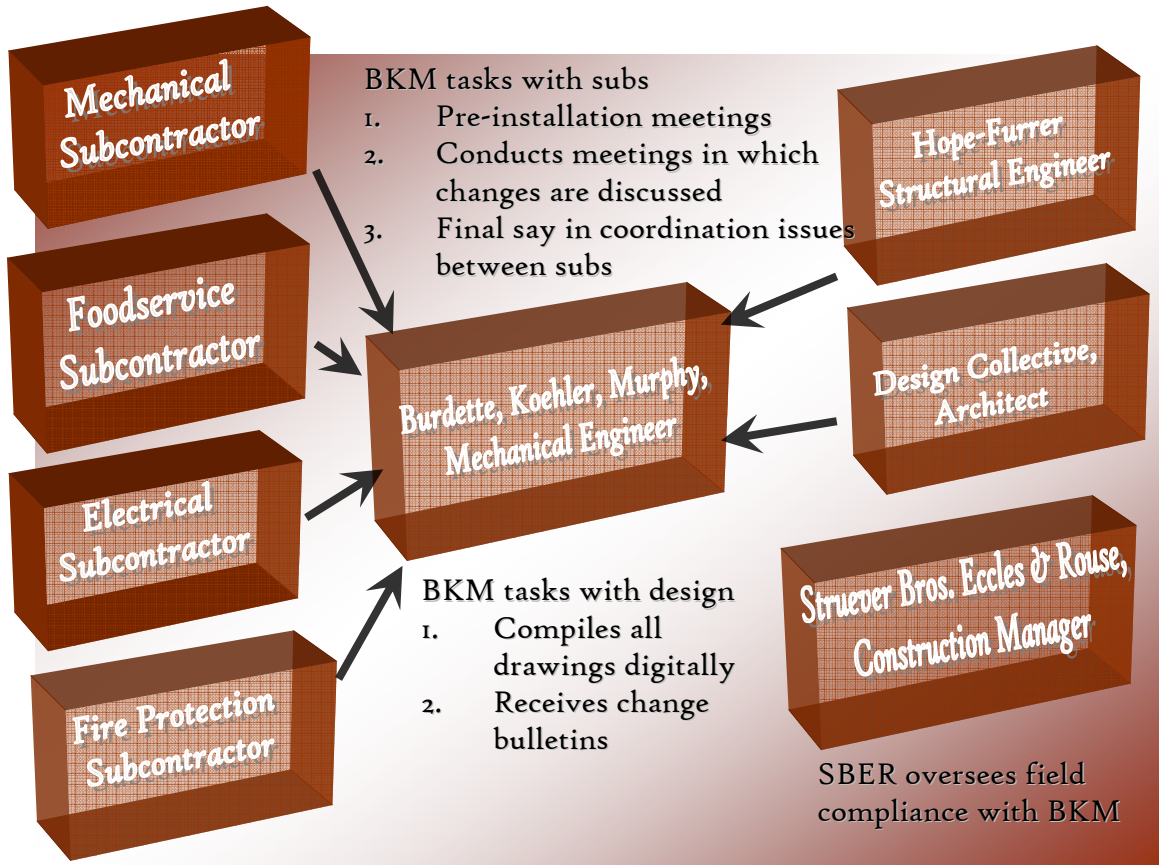

Figure 2: MEP Coordination process at Charles Commons

Finally, the MEP coordination process was performed during meetings by overlaying 2D drawings and completing a few mock-ups. The three-dimensional MEP digital modeling performed on the UW Research & Technology building proved to be very successful, although the process was not introduced until 50% development drawings. I believe that the complicated nature of the floor layouts on the first four floors would lend itself well to 3D digital modeling.



# Charles

# Commons

## *Analysis Goals:*

- *2-D Analysis: identify the areas in which ductwork can be redesigned to minimize conflict with other ductwork, columns, walls, ceilings, and piping*
- *Ductwork Sizing: size the ductwork, estimate the pressure drops, and determine the cost variations*
- *3-D Analysis: model the structural components (including both column plans), the HVAC ductwork and units, and the plumbing*
- *4-D Analysis: sequence the structural and mechanical components of the 3-D model to determine the system constructability*
- *Digital Modeling Comparison: compare the different model analyses to determine the best application for JHUCC*

The ultimate goal of the MEP analysis is to demonstrate the flexibility allowed with the alternative structural systems. The sections below show the “goal” plenum sizes and approximations of where the different systems will reside in the plenum. The MEP analysis performed here will validate the flat plate slab as the “best-value” option as compared to the existing post-tensioned slabs.

### *Plenum Analysis*

The post-tensioned system currently allows 3'-10" and 4'-2" plenum space and 10'-6" ceilings. The plenum can be divided and analyzed by the maximum height each of the following systems: HVAC ductwork, plumbing, and electrical/sprinkler. Since the electrical fixtures in the building were already specified with 5 1/2" maximum heights and sprinkler heads do not conflict with the lighting grid, the electrical/sprinkler space is allocated 6" of space. In the proceeding 3-D analysis, piping larger than 6" in diameter was modeled and checked to not conflict with the ductwork. Therefore, the plumbing space allocated is assumed to be 6".

Since insulation is integral with ductwork, an extra 2 inches was allocated for this purpose. This leaves 18" of ductwork on the 1<sup>st</sup> floor, 20" on the 2<sup>nd</sup> floor, and 24" on the 3<sup>rd</sup> floor. The aspect ratio was increased where individual ductwork sizes exceeded these parameters. However, the majority of the ductwork needed rerouted to prevent exceeding the ductwork height requirement.



# Charles

# Commons

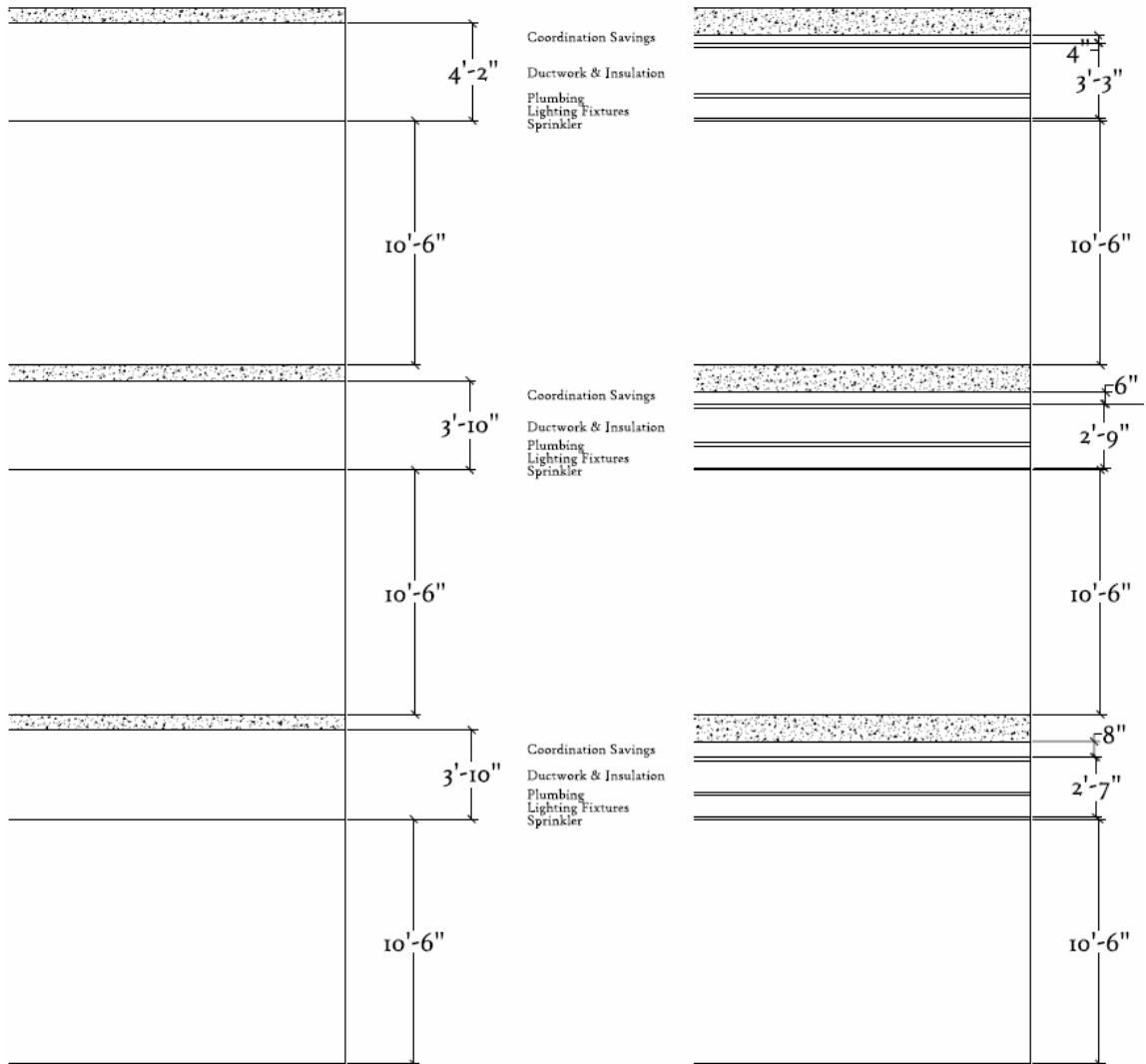

Post-Tensioned Slab

Flat Plate Slab

### Spatial Requirements

Both the St. Paul and Charles buildings were designed for the highest efficiency with space. The structure was designed post-tensioning to lower the floor-to-ceiling heights, the apartments had their own HVAC units, and the columns were designed far apart for an open floor plan. These measures allowed the Charles building to remain below the maximum building height.

The St. Paul building's first three floors introduce seemingly insurmountable complication to the Charles Commons project. The integration of a bookstore and



# Charles

# Commons

dining hall with the apartments render the placement of vertical risers difficult. In order to maintain large retail square footage, the mechanical and electrical rooms were minimized to near-closet proportions. Bathroom, kitchen, grease hood, and janitor's closet exhausts wreak havoc with the overhead supply and return ductwork. The open ceiling space in the dining hall, that features oval ductwork for architectural appeal, cannot be penetrated with rectangular main branch ductwork. Outdoor air intake is limited to the third floor northwest intake and the fourth floor courtyard intake. In addition, the 8" post-tensioned slab requires 6'x6' drop-caps for punching shear around all of the columns, which intrude on the limited plenum space in small corridor spaces.

## *St. Paul Mechanical System*

Parallel all-air systems and fan coil units supply the first three floors of the St. Paul building (4 air-handling units and 2 fan coil units). Two chillers and a cooling tower is located in the mechanical penthouse on the roof of the building. Smaller, localized fan-coil units are used in the dormitory units. The air-handlers work under a variable frequency drive and contain all of the standard compartments. The fan coil units are belt drive horizontal chilled water blower coil units and are fed from the chilled water coils from the penthouse.

At this point, different mechanical systems were considered, including the implementation of a DOAS system. Although this system meets many of the requirements of ASHRAE and is currently being tested at Penn State, many of the long-term effects of the DOAS system are unknown. Since the system is relatively unknown in the Baltimore market and there are barriers in finding a supplier of the DOAS, the possibility was stricken. I believe at a later date, the benefits of DOAS will be proven and it can be exploited on buildings with height requirements, such as Charles Commons. Since one of the themes of this thesis strives for decreasing lifecycle costs, investment in a DOAS system would not be conservatively wise.



# Charles

# Commons



Figure 6.1: Typical AHU courtesy of York International.

### Air-Handlers

AHU #	York Model #	Service (floor)	Capacity (cfm)	Min OA (cfm)	AHU Size (wxh) in.	Room Size (lxwxh) ft
AHU-4	500	Bookstore (2 <sup>nd</sup> )	25055	11200	125 x 95	48x36x10
AHU-5	305	Dining (2 <sup>nd</sup> )	12900	9000	103 x 64	48x36x10
AHU-6	215	Kitchen (3 <sup>rd</sup> )	10450	10450	91 x 55	32x15x10
AHU-7	305	Meeting (3 <sup>rd</sup> )	14800	14800	103 x 64	36x21x10



Figure 6.2: Typical fan-coil unit courtesy of Magic Aire.

### Fan-Coil Units

FCU #	Magic Aire #	Service (floor)	Capacity (cfm)	Min OA (cfm)	FCU Size (wxh) in.	Room Size (lxwxh) ft
FCU-1	60-HBAW-6	Lobby (1 <sup>st</sup> )	2500	250	72 x 48	48x36x10
FCU-3	24BVW	Bkstr. (2 <sup>nd</sup> )	400	0	48 x 48	16x14x10





## Charles

## Commons

## Two-Dimensional MEP Coordination Analysis

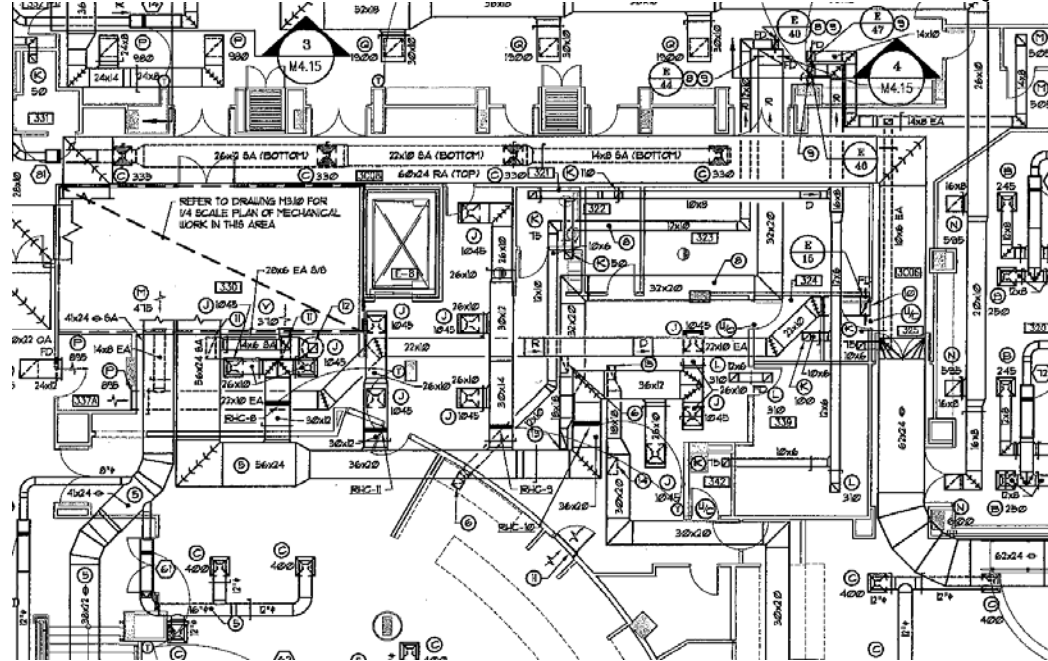

*Two-dimensional MEP coordination background*

A two-dimensional MEP coordination analysis begins with the review of the latest issue of the contract documents. There are two ways of reviewing the contract documents for MEP coordination. The pre-emptive solution in 2-D MEP coordination is for the drawings to be coordinated in 2D CAD through design development meetings to prevent overlapping layers. Typically this solution would involve the contractors during a Design-Build delivery and exclude their constructability analyses during a Design-Bid-Build delivery. The lack of construction expertise in the design phase limits most projects to the latter solution: the paper review.

The paper review occurs when contractors are introduced to the project at 100% construction documents. Contractors hold MEP coordination meetings onsite to determine the sequencing of the MEP trades and make decisions on plenum conflicts. This form of MEP coordination is the most frequent in construction.

Using the mechanical plans, areas in which ductwork crossed with other ductwork were analyzed and a solution was proposed in each of the six instances. Increasing the aspect ratio of the ductwork was not used in this analysis since most ductwork was at least 2:1 to 4:1. Any increases in this value could severely affect air flows and most of the limiting ductwork were already 3:1. These solutions were later checked in 3D. The timeframe for the 2D analysis was 4 hours.



## Charles

## Commons

## Ductwork Rerouting Issues

E1, Exhaust from 1<sup>st</sup> floor

The exhaust that serves the bathrooms, electrical room, mechanical room, and storage areas of the first floor exits the building on the north elevation of the 2<sup>nd</sup> floor. On the second floor, the 24" x 14" crosses a 58" x 18" supply for the second floor, which affects the minimum possible height for the second floor (32"). The rerouting of this exhaust through the corridor on the first floor bypasses the oversized 58" x 18" duct shrinking the plenum from 32" to 18". The floor penetration would not be possible with the post-tensioned structural slab since a post-tensioning tendon spans column to column in the exact area where the new duct riser is constructed. This rerouting of ductwork results in one more turn and a slightly longer branch.

The ductwork shown in grey is the omitted ductwork from the original plan and the areas shaded red is where the ductwork was rerouted. Ductwork is formally resized in the calculations following this section.

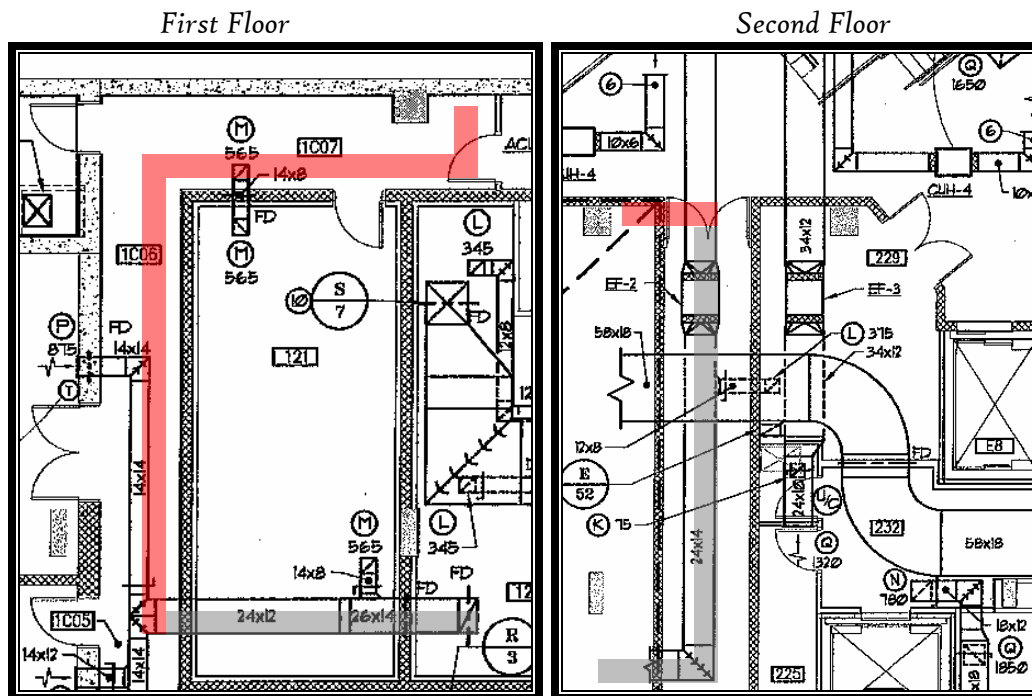



# Charles

# Commons

EB2, Return from 2<sup>nd</sup> floor bookstore

The return duct that criss-crosses along the bookstore plenum on the second floor serves the offices and bookshelves. The return from 2<sup>nd</sup> Floor bookstore spaces was rerouted to prevent crossing the 58" x 18" supply duct with a 18" x 6" duct. Instead, the 18" x 6" duct will cross the supply later in its run at the 48" x 14" size. The total ductwork length will increase significantly and the ductwork was sized larger to accommodate this. This rerouting of the ductwork decreases the HVAC from 24" to 20".

Second Floor

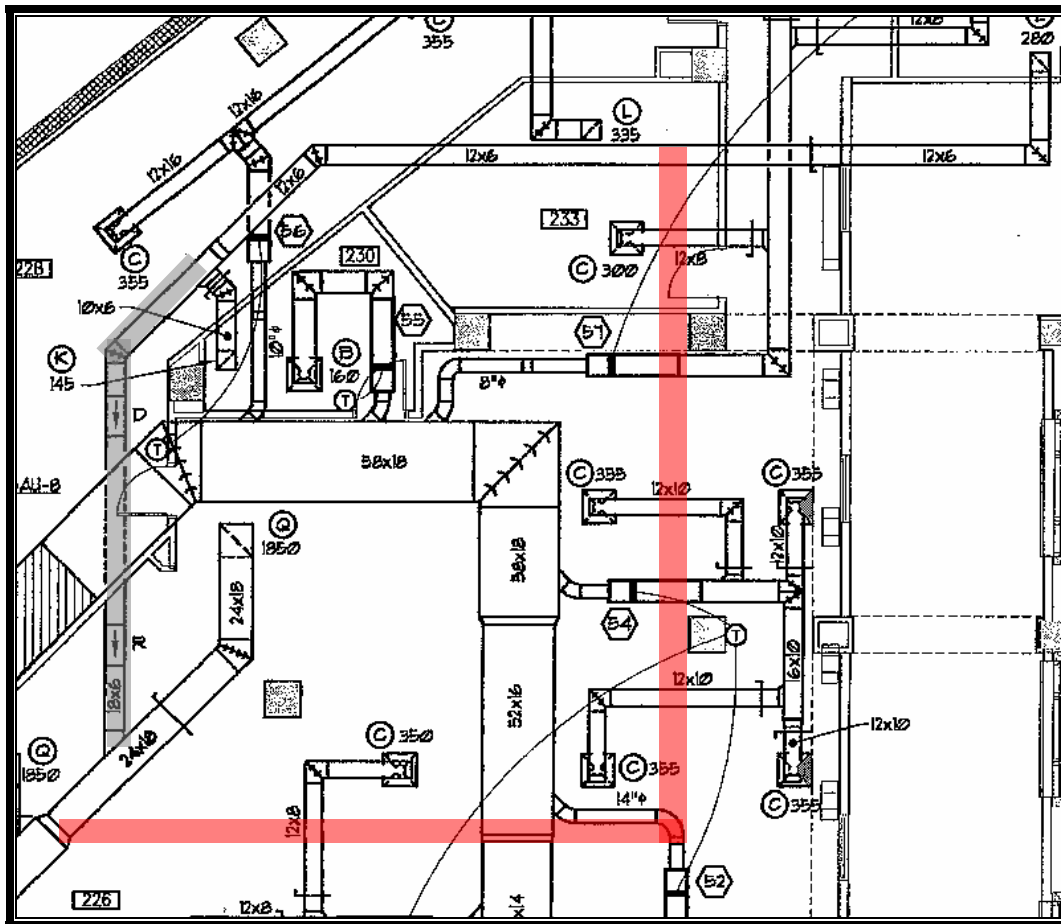



# Charles

# Commons

EB2.1, Main branch return from 2<sup>nd</sup> floor bookstore

The main branch of the return from the second floor bookstore was downsized to 18" to accommodate a concentrated area of plumbing and ductwork. To offset the increase of aspect ratio from 2:1 to 3:1, the ductwork was straightened to one 45-degree turn, saving two 90-degree turns.

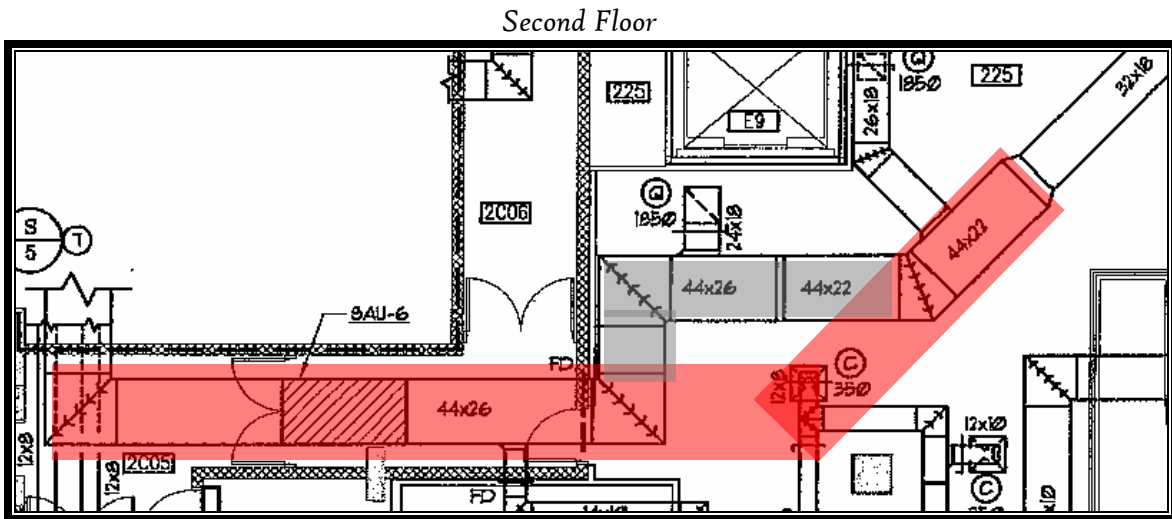







# Charles

# Commons

E<sub>3,1</sub>, Hood exhaust from 3<sup>rd</sup> floor kitchen

Exhaust from kitchen (grease hood exhaust) was moved to align with grease ductwork at the servery. The adjustment changed the arrangement of duct risers in two of the full-building access risers. The re-routing allowed the 32"x20" exhaust ductwork to utilize a nearly empty riser to move air that would have been otherwise built under a 60"x24" return duct. The flexibility of the flat-plate slab played into the routing by allowing a larger duct riser.

Third Floor

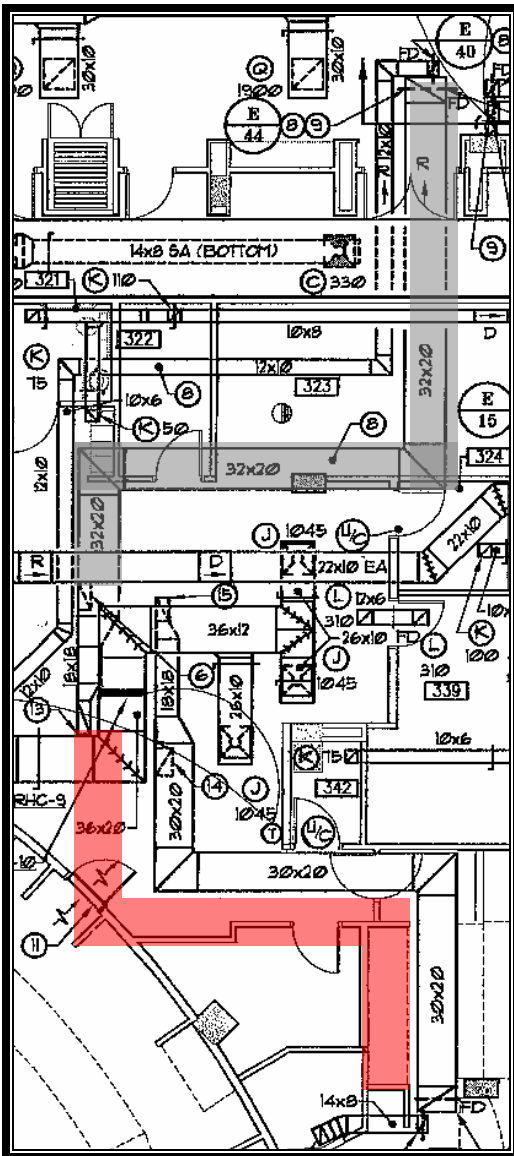



# Charles

# Commons

E3.2, Bathroom/Office exhaust from 3<sup>rd</sup> floor kitchen

Exhaust from the offices and bathrooms (non-grease) in the kitchen was re-routed to connect with the newly-amended E-3.1 ductwork. This allowed yet another piece of ductwork to avoid the large 60" x24" main branch return. In addition, less ductwork is employed to make the connection with the adjoining 32" x20" ductwork, which helps keep the ductwork sizes low.

Third Floor

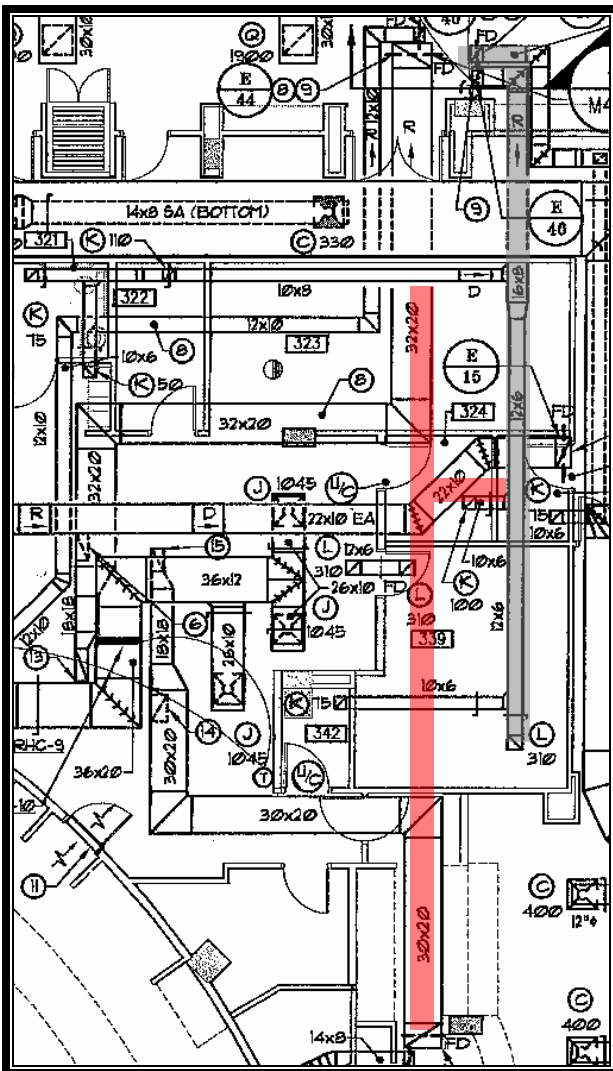



Charles

Commons

## Mechanical Ductwork Sizing

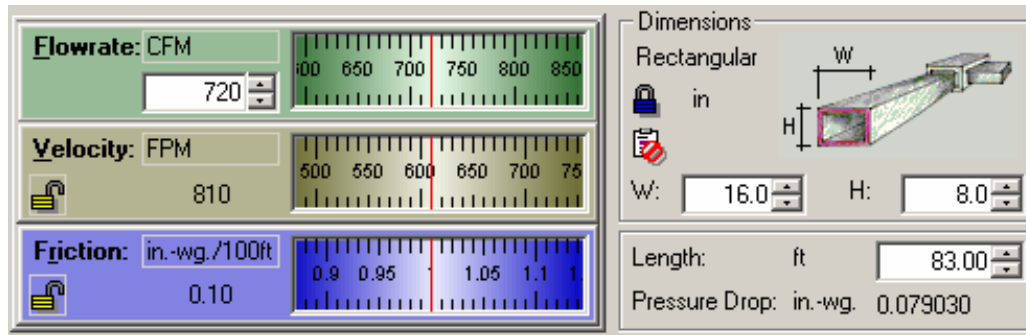

### Methodology

The mechanical ductwork is designed according to the limits of the flat-plate slab and conservation of mass flow. The following are approximately six variables that are associated with ductwork sizing:

- Air Flowrate (cfm)
- Air Velocity (fpm)
- Friction Losses (in.-wg/100ft)
- Equivalent Diameter Dimensions (in)
- Equivalent Length of Straight Duct (for turns)
- Pressure Drop (in.-wg.)

These six variables are necessary to compare ductwork branches and design equivalent branches. Variables such as air velocity, friction losses, and the number of turns are subject to change minimally during design and all steps are taken to maintain equivalence with the original system. For comparison sake, the pressure drop will be analyzed in the existing and revised conditions to arrive at simple conclusions. The pressure drop is the measure of the aggregate loss of air volume along the length of the duct branch.

### Applications

Two tools were used to calculate the mechanical ductwork rerouting: a ductolator and Marinsoft Duct Calculator. The ductolator is a rotating disc device that compares friction losses, velocity, flowrate, equivalent duct diameter, and duct dimensions. The back of the ductolator has approximate equivalent length of straight duct for different ductwork turns. For instance, conventional 90-degree turns with turning vanes in the horizontal are 25' and in the vertical are 15'.

The screenshot shown above is the Marinsoft Duct Calculator, which calculates everything that the ductolator can and uses the length of the ductwork to calculate the pressure drop in the individual ductwork branches. The Duct Calculator software is calibrated to the accepted values of 406 in.-wg. atmospheric pressure, 68



# Charles

# Commons

deg-F temperature, and  $0.0751 \text{ lb/ft}^3$  air density. Galvanized steel, continuously rolled, spiral seams with a roughness coefficient of  $0.00354$  in was used, corresponding with the existing ductwork material.

## Equations

- The velocity of air in a ventilation duct can be expressed in imperial units:

$$v = 144 * q / wd$$

where:

$v$  = air velocity (ft/min)

$q$  = air flow (cfm)

$w$  = width of duct (inches)

$d$  = width of duct (inches)

- The overall pressure loss in ducts can be expressed as:

$$dpt = dpf + dps + dpc$$

where

$dpt$  = total pressure loss in system

$dpf$  = major pressure loss in ducts due to friction

$dps$  = minor pressure loss in fittings, bends etc.

$dpc$  = minor pressure loss in components as filters, heaters etc.

- Major pressure loss in ducts due to friction can be expressed as

$$dpf = R * L$$

where

$R$  = duct friction resistance per unit length

$L$  = length of duct(ft)

- Duct friction resistance per unit length can be expressed as:

$$R = \lambda / dh (\rho v^2 / 2)$$

where

$R$  = pressure loss

$\lambda$  = friction coefficient

$dh$  = hydraulic diameter (ft)



## Charles

## Commons

## Duct Sizing Calculations

**E<sub>1</sub>**

Notes: Exhaust from 1<sup>st</sup> Floor special spaces (electrical rooms, bathroom, janitor's closet, and fire pump moved to decrease height requirement on 2nd floor from 18+14=32 to 18". May save some ductwork.

Location	Str. L.	Turns	Eq. L.	Total L.	Rect. Size	Equiv. Dia.	Air Flow	Velocity	Friction Loss	Pressure Drop
Existing Room 121	12	1	30	42	24x12	18	2095	1049	0.09	0.0388
	8	2	45	53	26x14	21	2660	1056	0.08	0.0424
1st Floor Corridor	2	1	15	17	14x8	12	565	736	0.08	0.0144
	17	1	30	47	14x14	15	875	638	0.04	0.0207
2nd Floor Corridor	40	1	15	55	24x14	20	2660	1144	0.1	0.0529
										<b>0.1692</b>
Adjusted Room 121	14	2	45	59	14x8	12	565	736	0.08	0.0499
1st Floor Corridor	14	0	0	14	24x14	20	1785	763	0.05	0.0064
	3	1	15	18	14x14	15	875	638	0.04	0.00792
	22	4	120	142	26x16	21	2660	924	0.06	0.0801
2nd Floor Corridor	6	1	30	36	26x16	21	2660	924	0.06	0.0203
										<b>0.1646</b>

**EB<sub>2</sub>**

Notes: Exhaust from 2<sup>nd</sup> Floor bookstore spaces moved to decrease height requirement on 2<sup>nd</sup> floor from 6+18=24 to 6+14=20".

Location	Str. L.	Turns	Eq. L.	Total L.	Rect. Size	Equiv. Dia.	Air Flow	Velocity	Friction Loss	Pressure Drop
Existing Room 226	32	1	25	57	18x6	11	425	565	0.06	0.0349
	8	2	20	28	12x6	9	425	848	0.15	0.0414
										<b>0.0763</b>
Adjusted Room 226	80	2	40	120	20x6	13	425	509	0.05	0.059
	8	1	30	38	10x6	11	145	356	0.03	0.0128
										<b>0.0718</b>

Ceiling needs lowered 10" (9'-6" ceilings)

**EB<sub>2.1</sub>**

Notes: Exhaust from 2<sup>nd</sup> Floor bookstore spaces moved to decrease height requirement on 2<sup>nd</sup> floor from 6+18=24 to 6+14=20". Will add some ductwork.

Location	Str. L.	Turns	Eq. L.	Total L.	Rect. Size	Equiv. Dia.	Air Flow	Velocity	Friction Loss	Pressure Drop
Existing Room 226	54	1	20	74	44x26	36	8650	1088	0.04	0.0309
	16	3	120	136	44x22	32	6755	1006	0.04	0.0558
										<b>0.0867</b>
Adjusted Room 226	54	1	25	79	56x18	33	8650	1235	0.07	0.052
	16	3	40	56	48x18	32	6755	1127	0.06	0.0326
										<b>0.0846</b>





# Charles

# Commons

### S<sub>3</sub>

Notes: Supply to conference corridor adjusted to AHU-6 mechanical room and through kitchen space.  
Allows ceiling to be lowered from 12+24=36" to 24" in corridor. Must switch to wall-mounted diffusers.

	Location	Str. L.	Turns	Eq. L.	Total L.	Rect. Size	Equiv. Dia.	Air Flow	Velocity	Friction Loss	Pressure Drop
Existing	Conference Corrido:	12	2	50	62	26x12	19	1325	616	0.03	0.0159
		22	0	0	22	26x12	19	990	460	0.02	0.0044
		20	0	0	20	22x10	16	660	430	0.02	0.0044
		22	0	0	22	14x8	12	330	436	0.03	0.0073
<b>0.032</b>											
Adjusted	Conference Corrido:	6	1	15	21	30x12	20	1325	534	0.02	0.0052
		Room 330	46	4	70	116	30x12	20	990	398	0.01
	Kitchen	16	1	25	41	14x14	14	330	249	0.01	0.002
		12	0	0	12	28x12	20	660	282	0.01	0.00097
		16	1	25	41	14x14	14	330	249	0.01	0.002
		32	3	60	92	14x14	14	330	249	0.01	0.0049
<b>0.0321 0.0001</b>											
<b>negligible</b>											

### E<sub>3.1</sub>

Notes: Exhaust from kitchen (E-40, grease exhaust) moved to align with grease duct at servery and through deleted column.  
Allows ceiling to be lowered from 20+24=44" in corridor. Must realign parallel exhaust (E-53) as well.

	Location	Str. L.	Turns	Eq. L.	Total L.	Rect. Size	Equiv. Dia.	Air Flow	Velocity	Friction Loss	Pressure Drop
Existing	Kitchen	6	0	0	6	18x18	18	3200	1422	0.14	0.00849
	Conference Room	60	2	80	140	32x20	27	5840	1316	0.08	0.11727
<b>0.1258</b>											
Adjusted	Kitchen	6	0	0	6	18x18	18	2640	1177	0.1	0.0059
	Conference Room	38	2	80	118	32x20	27	5840	1316	0.08	0.09885
<b>0.1048 0.021</b>											

### E<sub>3.2</sub>

Notes: Exhaust from kitchen spaces (E-46) moved to an added space that follows an apartment furnace space to the penthouse for release. Allows ceiling to be lowered from 8+24=32" in corridor. Includes 10x6 EA from room adjoining trunk line.

	Location	Str. L.	Turns	Eq. L.	Total L.	Rect. Size	Equiv. Dia.	Air Flow	Velocity	Friction Loss	Pressure Drop
Existing	Room 342	12	1	15	27	10x6	8	75	203	0.01	0.0034
	Room 339	3	0	0	3	12x6	8	310	636	0.09	0.0026
		14	0	0	14	12x6	8	385	763	0.12	0.0171
		3	1	15	18	10x6	8	100	254	0.02	0.0033
	Room 325	14	0	0	14	12x6	8	485	975	0.19	0.0267
	Room 321	10	0	0	10	10x8	8	125	229	0.01	0.0012
	Room 322	24	1	15	39	10x8	8	235	420	0.04	0.0142
	Conference Room	18	1	65	83	16x8	12	720	810	0.1	0.079
	<b>0.1475</b>										
	Adjusted	Room 321	10	0	0	10	10x6	8	125	305	0.03
Room 322		18	1	30	48	10x6	8	235	559	0.08	0.0363
Room 324		16	0	0	16	12x6	8	335	678	0.1	0.0158
Kitchen		12	0	0	12	12x6	8	435	890	0.16	0.0194
Room 342		7	1	15	22	10x6	8	75	203	0.01	0.0027
Room 339		4	0	0	4	16x8	12	720	810	0.1	0.0038
Dining Servery		16	0	0	16	30x24	29	6560	1314	0.08	0.0121
<b>0.0927 0.055</b>											



## Charles

## Commons

## Value Engineering

The cost estimate of the ductwork changes amounts to less than \$1,200. As demonstrated in the structural section, the savings of 18" in the overall height of the St. Paul building amounts to approximately \$396,000 savings. The costs of instituting a 3-D digital model will be discussed later. Therefore, the rerouting of six branches of ductwork on three floors to lower the height of the plenum produced a cost savings of \$394,800 on the St. Paul building.

**MEP Value Engineering**

15810 Metal Ductwork	Total:	\$	(282.30)	lb					
	Crew	Daily Output	Quantity	Unit	Mat	Labor	Equip	Total	
Galvanized Steel	Q-10	\$	285.00	\$ (282.30)	lb	\$ 0.48	\$ 3.31	\$ -	\$ 3.79
						\$ (135.50)	\$ (934.41)	\$ -	\$ (1,069.92)
	For Duct Insulation: add 10%								\$ (1,176.91)
<b>Existing:</b>		<b>\$</b>	<b>3,753.50</b>						
<b>Adjusted:</b>		<b>\$</b>	<b>4,035.80</b>						
<b>Difference:</b>		<b>\$</b>	<b>(282.30)</b>						

The adjusted return air system costs \$1,177 more than the existing MEP drawings.

**E1**

	Location	Str. L.	Rect. Size	Equiv. Dia.	Sum-2 Sides	Lbs/Lf	Lbs
Existing	Room 121	12	24x12	18	36	7.8	93.6
		8	26x14	21	40	8.6	68.8
	1st Floor Corridor	2	14x8	12	22	4.7	9.4
		17	14x14	15	28	6	102
	2nd Floor Corridor	40	24x14	20	38	8.2	328
							<b>601.8</b>
Adjusted	Room 121	14	14x8	12	22	4.7	65.8
	1st Floor Corridor	14	24x14	20	38	8.2	114.8
		3	14x14	15	28	6	18
		22	26x16	21	42	9	198
	2nd Floor Corridor	6	26x16	21	42	9	54
							<b>450.6</b>
							<b>-151</b>

**EB2**

	Location	Str. L.	Rect. Size	Equiv. Dia.	Sum-2 Sides	Lbs/Lf	Lbs
Existing	Room 226	32	18x6	11	24	5.2	166.4
		8	12x6	9	18	3.9	31.2
							<b>197.6</b>
Adjusted	Room 226	80	20x6	13	26	5.6	448
		8	10x6	11	16	3.4	27.2
							<b>475.2</b>
							<b>278</b>

**EB2.1**

	Location	Str. L.	Rect. Size	Equiv. Dia.	Sum-2 Sides	Lbs/Lf	Lbs
Existing	Room 226	54	44x26	36	70	17.5	945
		16	44x22	32	66	16.5	264
							<b>1209</b>
Adjusted	Room 226	54	56x18	33	74	18.5	999
		16	48x18	32	66	16.5	264
							<b>1263</b>
							<b>54</b>



## Charles

## Commons

<b>S<sub>3</sub></b>							
	<i>Location</i>	<i>Str. L.</i>	<i>Rect. Size</i>	<i>Equiv. Dia.</i>	<i>Sum-2 Sides</i>	<i>Lbs/Lf</i>	<i>Lbs</i>
Existing	Conference Corridor	12	26x12	19	38	8.2	98.4
		22	26x12	19	38	8.2	180.4
		20	22x10	16	32	6.9	138
		22	14x8	12	22	4.7	103.4
							<b>520.2</b>
Adjusted	Conference Corridor	6	30x12	20	42	10.5	63
	Room 330	46	30x12	20	42	10.5	483
		16	14x14	14	28	3	48
	Kitchen	12	28x12	20	40	8.6	103.2
		16	14x14	14	28	3	48
		32	14x14	14	28	3	96
							<b>841.2</b>
							<b>321</b>
<b>E<sub>3.1</sub></b>							
	<i>Location</i>	<i>Str. L.</i>	<i>Rect. Size</i>	<i>Equiv. Dia.</i>	<i>Sum-2 Sides</i>	<i>Lbs/Lf</i>	<i>Lbs</i>
Existing	Kitchen	6	18x18	18	36	7.8	46.8
	Conference Room	60	32x20	27	52	13	780
							<b>826.8</b>
Adjusted	Kitchen	6	18x18	18	36	7.8	46.8
	Conference Room	38	32x20	27	52	13	494
							<b>540.8</b>
							<b>-286</b>
<b>E<sub>3.2</sub></b>							
	<i>Location</i>	<i>Str. L.</i>	<i>Rect. Size</i>	<i>Equiv. Dia.</i>	<i>Sum-2 Sides</i>	<i>Lbs/Lf</i>	<i>Lbs</i>
Existing	Room 342	12	10x6	8	16	3.4	40.8
	Room 339	3	12x6	8	18	3.9	11.7
		14	12x6	8	18	3.9	54.6
	Room 325	3	10x6	8	16	3.4	10.2
		14	12x6	8	18	3.9	54.6
	Room 321	10	10x8	8	18	3.9	39
	Room 322	24	10x8	8	18	3.9	93.6
	Conference Room	18	16x8	12	24	5.2	93.6
							<b>398.1</b>
Adjusted	Room 321	10	10x6	8	16	3.4	34
	Room 322	18	10x6	8	16	3.4	61.2
	Room 324	16	12x6	8	18	3.9	62.4
	Kitchen	12	12x6	8	18	3.9	46.8
	Room 342	7	10x6	8	16	3.4	23.8
	Room 339	4	16x8	12	24	5.2	20.8
	Dining Servery	16	30x24	29	54	13.5	216
							<b>66.9</b>



Charles

Commons

## Three-Dimensional MEP Coordination Analysis

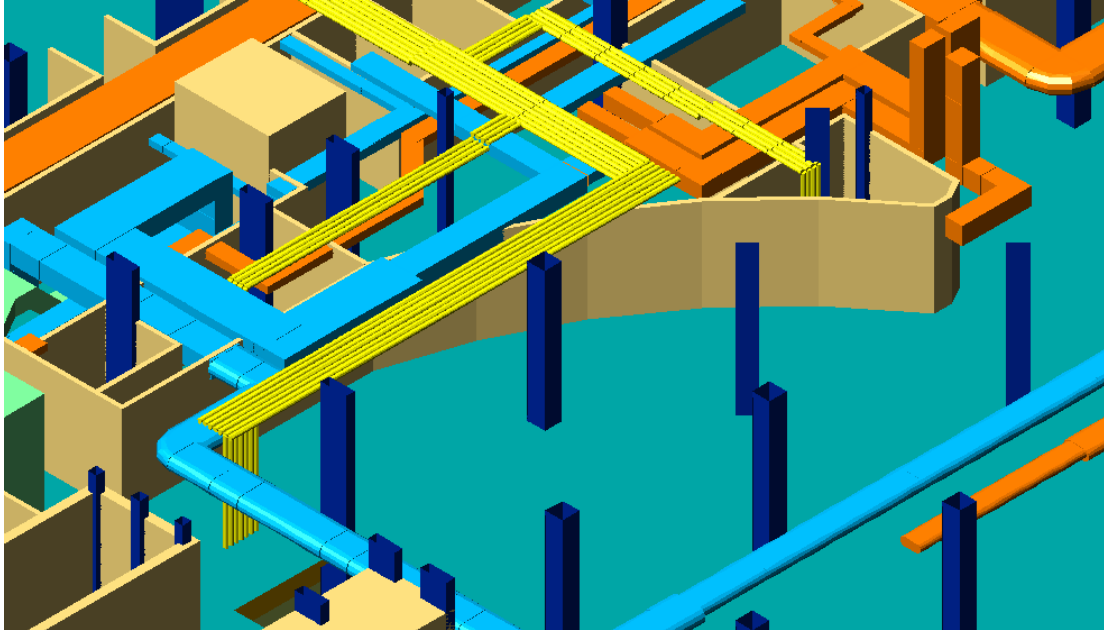

*Three-Dimensional CAD Background*

Three-dimensional digital modeling using CAD programs have been studied at Penn State for many years, although the use of 3-D in the practice is quite sparse. Three-dimensional modeling requires CAD technology that can be a tough investment barrier for many companies, but it has been proven many times that 3-D CAD modeling can pay for itself on each project. Why is it not used more often?

- New technology: As with many new technologies, awareness is the major first-step.
- Lack of 3-D CAD technicians: There are very few programs in the country that surpass the standard 2-D CAD curriculum.
- 3-D CAD Software Deficiencies: Some argue that the current AutoCAD 2006 3-D software does not have enough stream-lined tools for the time-stringent building industry. Which software is best to use for 3D CAD analysis? Will there be better software in 6 months?
- No driving proponent: There are no members of the project team that have a specific investment of interest in this technology: MEP engineers don't want to spend the extra time, MEP subcontractors charge for the service, and most superintendents are practical-minded individuals that can be "computer-challenged." Only the project managers are in the position to "sell" 3-D CAD to the owner and the division manager of their company.



# Charles

# Commons

As described by Jessica Potkovich, 2005 Architectural Engineering graduate, there are many benefits of 3-D CAD, which are listed below.

- Higher Quality of Work: CAD makes it easier to explore different results and offers improved accuracy and aesthetics.
- Ability to Eliminate Interferences: Allows you to identify system interferences.
- Personal Development and Achievement of Staff: Implementing CAD technology opens up new positions and provides a challenging environment for staff.
- Better Team Communication: Allows for more efficient collaboration because system is paperless.
- Design Flexibility: CAD offers tools that allow for quick and easy modification of designs.

Deciding whether to use or not use three-dimensional analysis is not a frequented decision amongst the project management staff. It was first implemented by CollinsWoerman, a Seattle-based architectural firm, on the UW Research & Technology project that was discussed in the DBOM/BOT section of this report. The first respondent, Jon Szczesniak, worked on the digital modeling required for the coordination of this high-tech laboratory. The floor-to-floor height was reduced from 15' to 13'-6" as a result of the 3-D digital modeling. The introduction of digital modeling was described by Mr. Szczesniak in the following:

*It's important to realize that out here, in Seattle, the idea of digital coordination is fairly fresh. There have only been a handful of projects that have used this to it's fullest capacity. I believe it was Mortenson who had originally brought up the idea of modeling the building in three dimensions for the explicit purpose of coordinating the different trades that were to make up this Research & Tech. building. They have done similar processes on the Disney Concert Hall, and it is becoming their standard way to work with architects and all subs.*

The primary purpose of the 3D modeling was for MEP coordination, which began in the middle of the construction document phase. It was Jon Szczeniak's opinion that if the 3D modeling was started earlier, at the beginning of the design development phase, the design could have been coordinated between the professional engineers and not require the added coordination costs incurred by the subcontractors. Nevertheless, Mr. Szczeniak went on to describe the process:

*... the design sequence/timeframe was from the CD phase through construction. We got together every other Tuesday and went through the project. Each floor was separated out and coordinated by itself. We used specialized software that would allow us to view the building stereoscopically in real-time so that we could see that when plumbing had a collision with*



# Charles



# Commons

*electrical, we could zoom right to it and see how to best resolve the issue. Each coordination meeting had parties from all trades.*

Mr. Szczeniak and Mr. Whitlow believed that this MEP coordination process was a success that saved the UW Research & Technology Building in lower building height, construction conflicts, and access issues. Without the project team cooperation that results from a DBOM delivery, the UW Research & Technology Building may not have considered the cost and schedule benefits from 3-D MEP Coordination.

## *3D Mechanical Rooms*

### *Second Floor Mechanical Room, AHU 4 & 5*

Although the 3-D modeling was very useful for the branch ductwork rerouting, it can be even more integral to the construction of the cramped mechanical rooms. All of the mechanical rooms did not have complete attached ductwork. For example, outdoor air ductwork did not connect with the AHU's, it only terminated inside the mechanical rooms. Two full-size AHU's and a fan-coil unit were squeezed into this space. The blue ductwork (Outdoor Air) is funneled in from the 5<sup>th</sup> floor courtyard intake. The brown ductwork (Supply Air) supplies the bookstore spaces and the orange ductwork (Return/Exhaust Air) returns to be mixed with the OA. In addition, chilled water from the rooftop chillers cycle to this room and distributes to the 1<sup>st</sup> floor fan-coil unit.



# Charles

# Commons

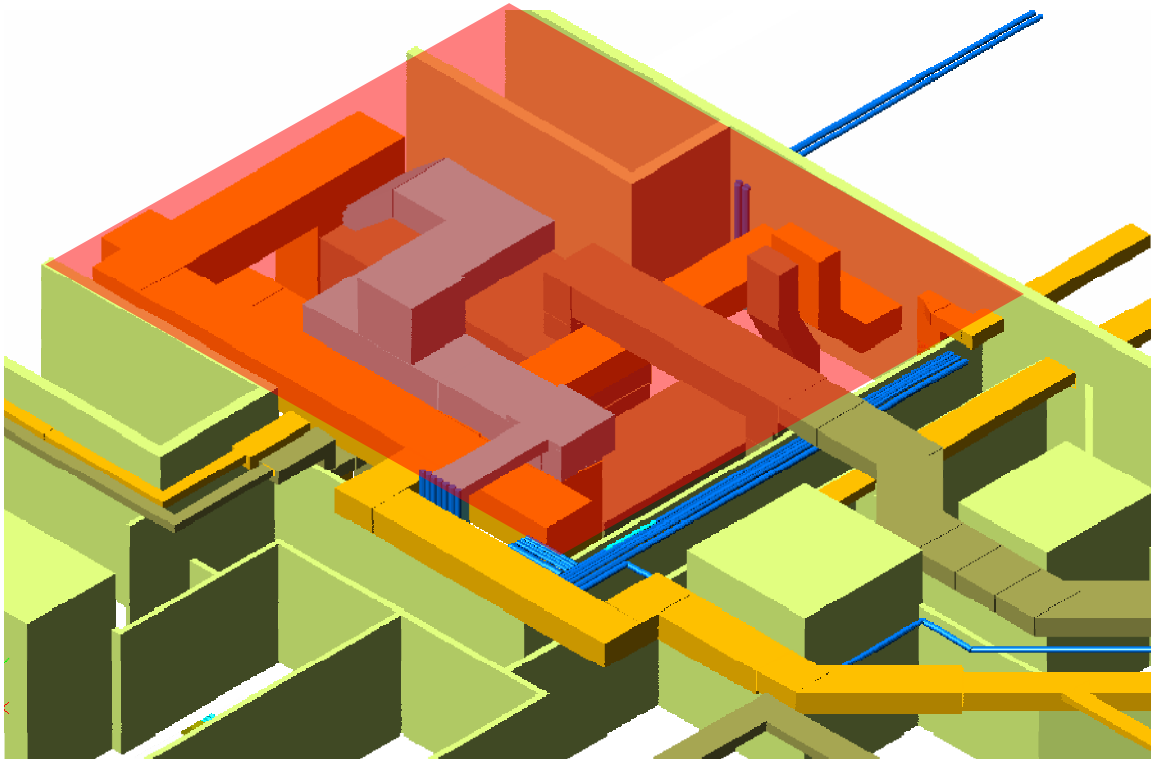

*Third Floor Mechanical Rooms, AHU 6 & 7*

The nearest mechanical room intakes exhaust air from the 3<sup>rd</sup> floor intake from Lovegrove St. This AHU supplies (yellow ductwork) the adjacent conference room. The return/exhaust air (tan ductwork) cycles back to the AHU and mixes with the intake OA air, returning to AHU 7.

The smaller mechanical room feeds supply air to the kitchen and dining room spaces and returns air through a small corridor between the mechanical room and the conference room. This return duct is 60"x24" and three of the six ductwork rerouting dealt with adjusting all of the ductwork around it. The purple chilled water piping supplies the AHU's and the kitchen equipment/sinks.



# Charles

# Commons

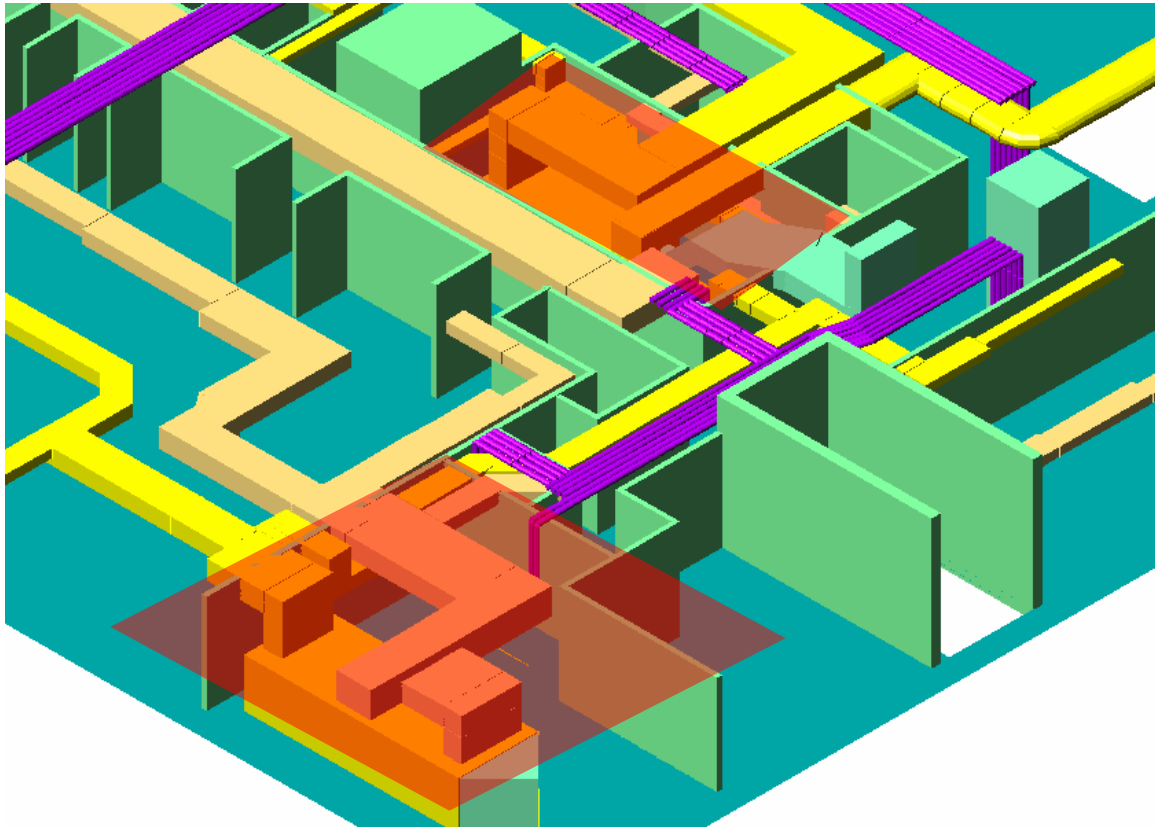



# Charles

# Commons

## Four-Dimensional MEP Coordination Analysis

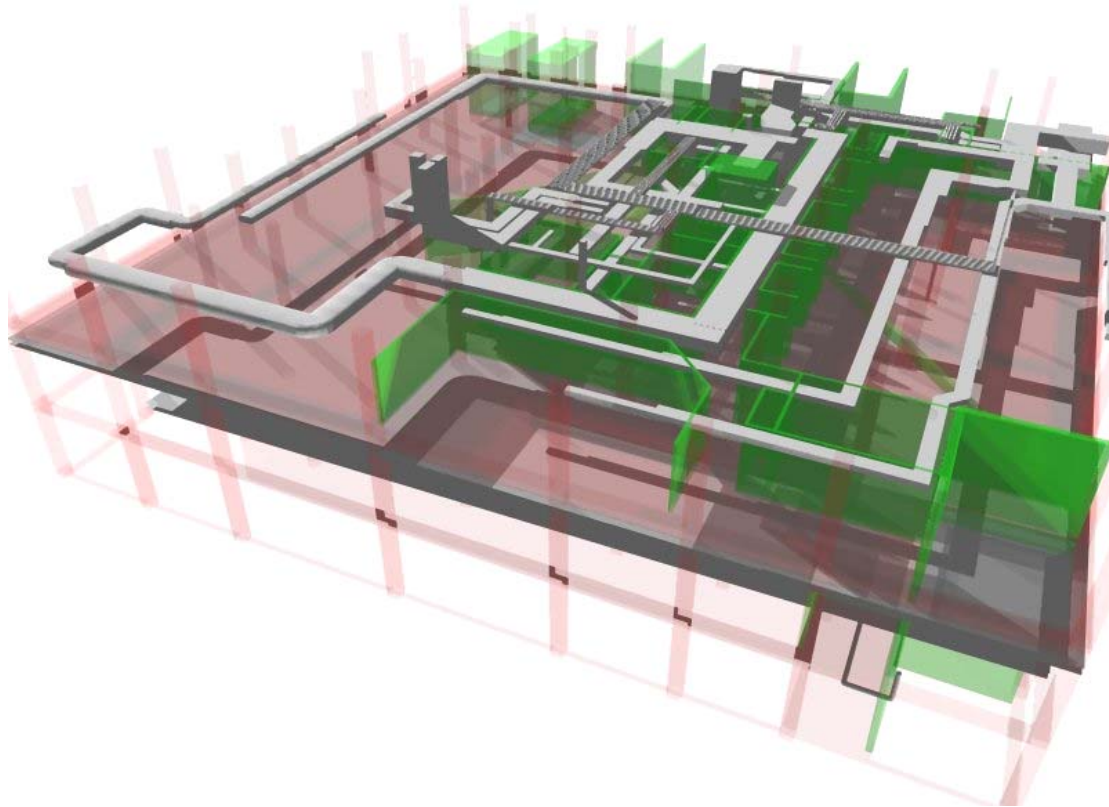

### *Four-Dimensional CAD Background*

A few years ago, time was added to three-dimensional CAD, as had been done to photographs to create motion-pictures many decades before. But the quest was different, ticket sales was not the product of the added dimension. Four-dimensional CAD produces the understanding of a 2-D paper schedule combined with a 3-D building model. In all intents and purposes, two and three dimensions should produce five dimensions.

The primary difference between 3-D and 4-D CAD is not time, but its use in the project. 3-D CAD is used best in the design stages, when design professionals are not sure that their design, when constructed, will compete with other systems or not be desirable. 4-D is used for construction managers in the common pursuit of sequencing excellence. Few project managers have the experience to sequence construction with the same talent and sixth-sense ability of the veteran superintendents. However, on extremely-complicated and time-constrained projects, 4-D CAD can help guarantee the project's success. The following are disadvantages of 4-D CAD in addition to 3-D CAD.

- **Lack of 4-D CAD equipment:** There are very few 3-D labs in the country, due mostly to their very large cost. In addition, offices that already lack space for



# Charles

# Commons

their own employees must donate large conference rooms full of equipment for such an endeavor.

- 4-D CAD Software Deficiencies: Not only do technicians need to deal with individual software problems, but the cross-importing that takes place between the 3-D software, schedule software, and the 4-D compiler can be difficult in itself. No single-point software has been developed yet.
- Construction software: 4-D CAD needs 3-D CAD cooperation from the engineers and a compelling urge from the construction side to “go where no one has gone before.”
- Two variables: Not only do design changes affect the model, but schedule effects have an excellent chance to disrupt the entire process.
- Superintendent Sequencing Input: 4-D tests superintendent computer skills and patience. 4-D coordination requires too much of the superintendent’s time and subcontractor foremen could get confused. Only for the most adventurous superintendents (project managers should not be involved).

The advantages of 4-D include the advantages of 3-D and the following:

- Looks Cooler: Owners may be entertained by the motion of the pictures.
- Ability to Eliminate Sequence Problems: Allows you to identify system interferences and sequence problems before the system gets placed.

4-D CAD seems to be a tool in the superintendent’s toolbox and 3-D CAD seems to be a tool in the project management/design box. On jobs in which more than three superintendents are employed and the building is extraordinarily complicated or large, 4-D may be a good consideration. In addition, more areas are applicable to the 3-D CAD such as structural conflicts, architectural rendering, and more refined interior walkthroughs. 4-D CAD surfaces are dulled down to basic colors in Navisworks to allow the program to work, where 3-D CAD surfaces imported to 4-D Viz can produce realistic architectural walkthroughs.

### *Constructability Review*

The MEP sequencing for the first three floors of St. Paul building are difficult. There are no obvious “typical” bays, no even distributions of systems, and no common layout on each floor. However, each floor has a similar sequence for laydown, secondary spaces, and auxiliary spaces. For example, sequence 1 begins in the area of the bookshelves near the material hoist (northeast arrow) with the CMU block layers so that it is easy to store palettes to begin the production week. Since there is little block to lay in sequence 1, the block-layers can easily move to the next space and stay ahead of the interior partitions. As the interior framing crews get ahead as well, the ductwork rough-in can laydown their sheetmetal and work the branches toward the mechanical equipment. All of the other trades cycle on the heels of the HVAC sheetmetal workers. The last space to complete is the exposed ceiling





# Charles

# Commons

dining area on the third floor, where care can be taken to maintain the aesthetics of the exposed oval-ductwork.

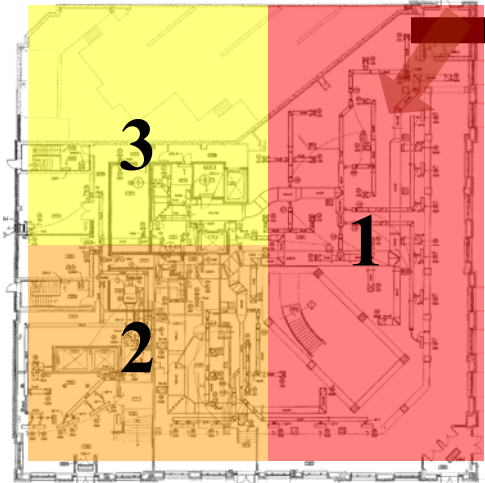

### First Floor Sequence (1-3)

1. Bookshelves – space is expansive to store the 1<sup>st</sup> floor's load of material by utilizing material hoist (northeast arrow).
2. Lobby – the space is not overcomplicated with ductwork or plumbing, block layers get ahead. Install FCU-1.
3. Auxiliary Rooms – fire pump and electrical rooms are laid out and electrical is fed into the building.

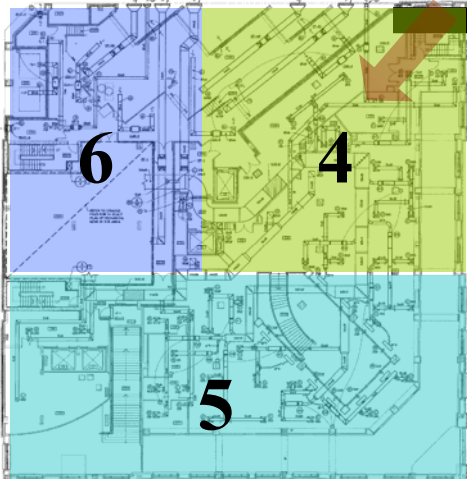

### Second Floor Sequence (4-6)

4. Bookshelves – space is expansive to store the 2<sup>nd</sup> floor's load of material by utilizing material hoist.
5. Lobby – the space is not overcomplicated with ductwork or plumbing, block layers get ahead.
6. Mechanical Room 1 – AHU's 4 & 5 are installed and a myriad of ductwork is installed.

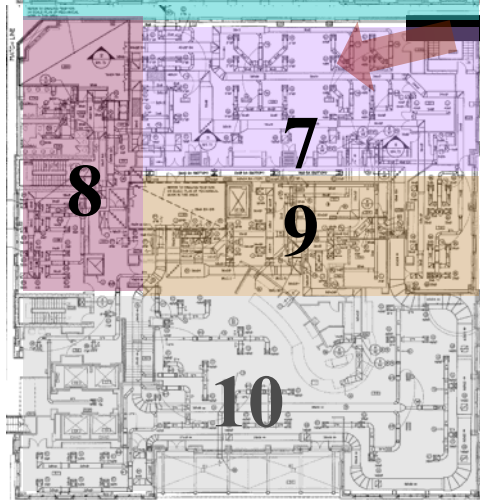

### Third Floor Sequence (7-10)

7. Conference Room – space is expansive to store the 3<sup>rd</sup> floor's load of material by utilizing the material hoist.
8. Mechanical Room 2 – AHU 7 is installed and ductwork is extended to the adjacent mechanical room.
9. Mechanical Room 3 – AHU 6 is installed and the kitchen exhausts and piping is installed.
10. Dining Room – oval ductwork is installed and lighting is positioned.

### 4-D Sequencing Analysis



# Charles

# Commons

Designations:

Arrow - flow of materials from the material hoist

Structure - blue columns are in-construction, red columns are completed

MEP - yellow areas are in-construction, grey areas are completed

Day 36

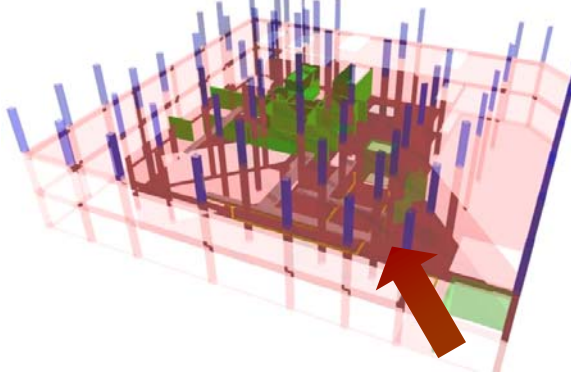

Day 42

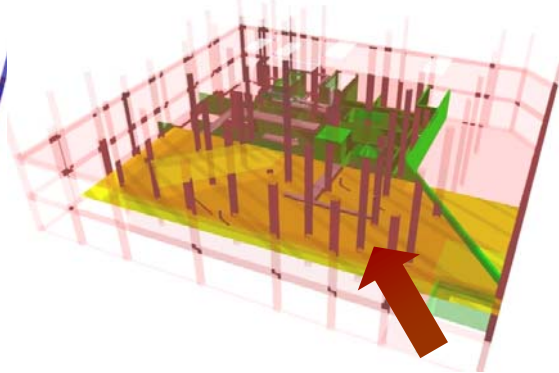

Day 52

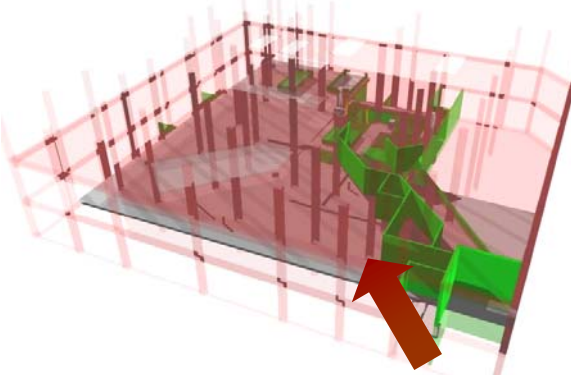

Day 66

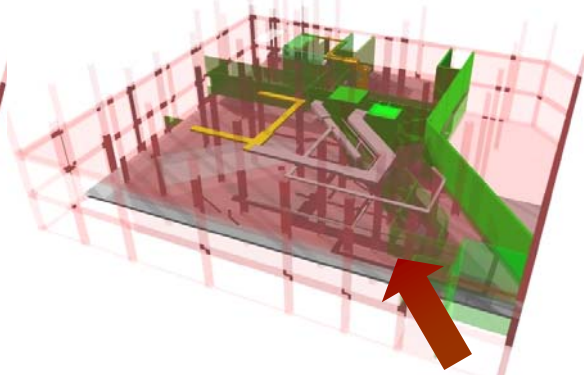

Day 85

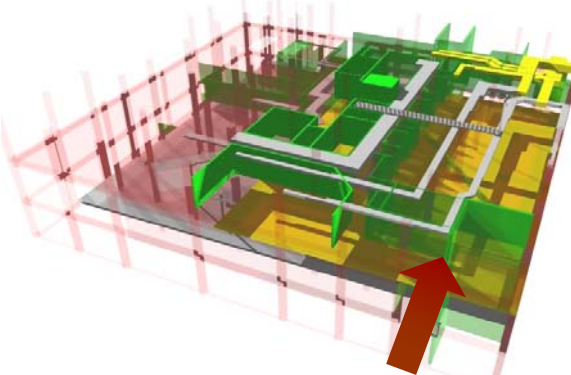

Day 99

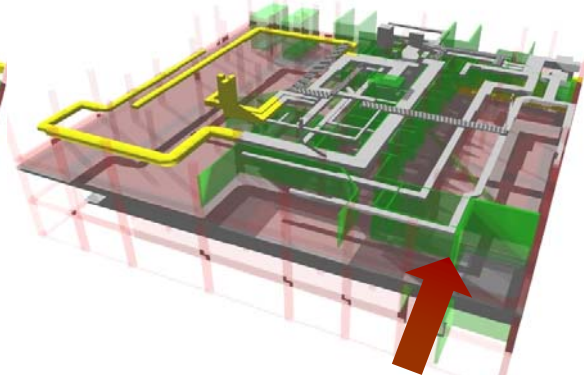



# Charles

# Commons

The analysis of the 4-D sequencing using Navisworks showed the inherent complexity of the 10-sequence system I had proposed before. Each area overlaps another area due to the inherent uneven production caused by the “custom” floor plans of the first three floors. Since it was impossible to cut each floor into perfectly manageable sections, the opening floor sequence was designed to allow the other trades to stay ahead of the MEP workers. In many areas, ductwork and plumbing overlap adjacent wall construction and vice versa. This is the single most important limiting factor for 4-D sequencing.

4-D modeling is excellent for equally-divisible and work-intensive spaces such as analyses using SIPS or Short-Interval Production Schedules. Although the apartment spaces in St. Paul and Charles buildings are equally-divisible, the work inside each apartment is not work-intensive. Instead, each of these floors were constructed simultaneously, with multiple crews working all of the floors at once. The first three floors of the St. Paul building bogged down in the non-repetitive work, where the layouts changed constantly and each space was work-intensive in its own way. These two factors are what would constitute an ineffectiveness on the part of 4-D modeling on the St. Paul building.

*MEP Coordination Analysis Comparisons*

Analysis Method	Time to Complete	Coordination/Sequencing Issues Fixed
2-D	4 hours	6
3-D	24 hours combined	2
4-D	32 hours combined	0

Analysis Method	Advantages	Disadvantages
2-D	Superintendent comprehend fully Universal process No barriers	Difficult to communicate Difficult to analyze height conflicts Low ability to eliminate interferences Little design flexibility
3-D	Higher quality of work Ability to eliminate interferences Personal development and achievement of staff Better team communications Design flexibility	New technology Lack of 3-D CAD technicians 3-D CAD software deficiencies No driving proponent
4-D	Looks cooler Ability to eliminate sequence problems	Lack of 4-D CAD equipment 4-D CAD software deficiencies Construction software Two variables Superintendent sequencing input

*Charles*



*Commons*

*Mechanical Conclusion*

Three-dimensional digital modeling is the best method to alleviate the MEP coordination issues associated with floors 1-3 of the St. Paul building. The benefits of communicating complicated spaces such as cramped mechanical rooms and adding piece-of-mind such that the ductwork will not conflict with the walls and other systems make the extra 24 hours worth the time. In addition, it is in the project's best interest for the 3-D digital modeling for the MEP systems be performed during the design development stages of the project so that designs provided by the mechanical engineer can be more useful, as done on the UW Research & Technology Building.

Two-dimensional analysis is useful for superintendents and personnel that are using the information for their own job. Communication of a 2-D analysis is very difficult and the drafting of such documents can take longer than that of 4-D digital modeling. In addition, the process requires the user to be able to perceive the height limitations and have a three-dimensional mind.

Four-dimensional models are very convenient constructability analyses tools, but are very difficult to communicate. 4-D modeling helps eliminate sequencing issues on typical sequence structures and work-intensive areas. However, the custom layout of the 1<sup>st</sup>-3<sup>rd</sup> floors of the St. Paul building make sequencing accuracy and comprehension more difficult than on other projects.





# Charles

# Commons

## *Recommendations*

In order to improve the decision-making of the project team on Charles Commons, analyses were conducted to change the delivery method, the structural slab system, and the MEP coordination process. Each one of these analyses resulted in a change to the existing system, although many of the alternatives were not taken.

The following changes were taken:

- Design-Build-Operate-Maintain: saves on long-term costs and 10 months
- Flat-Plate Structural Slab: saves \$731,412, including 48 days
- 3-D MEP Coordination/Duct Rerouting: saves \$394,823

These analyses were initiated to take a multi-faceted approach at the design, coordination, and construction processes of Charles Commons in order to pin-point errors relating to the decision-making of the owner, engineer, and construction manager. It has been proven that with more-informed decision-making, the project team would have averted the debilitating delays and overruns associated with the dining hall, bookstore, and lobby spaces in the St. Paul building.





*Charles*

*Commons*

*Appendix A*

# Research & Technology Building

Andy Casillas, Project Manager

## **PROJECT DESCRIPTION**

The lack of available research space is the constraining factor to expanding and remaining nationally competitive in research. Preparing additional Seattle campus space will provide an opportunity to expand multi-disciplinary research initiatives in high growth areas that need to be located near the campus. The Administration proposes to meet this need in a similar fashion to the private sector, by providing a competitively priced, highly flexible and adaptable research building core and shell, in which UW research entities would build out their required spaces. The building will be approximately 115,000 gross square feet. The selected site for the new building is the existing surface parking lot W44, west of the Publications Services building, on NE Northlake Place.

The Administration proposes to procure the core and shell research building using the design-build-operate-maintain (DBOM) alternative public works procurement process, as authorized by RCW 39.10.051. This procurement method is envisioned to provide the much-needed additional research space in a shorter amount of time and in a more cost-competitive manner than other, more traditional methods. In addition to design and construction, the procurement will likely include a building operation component.

## **PROJECT MANAGER'S STATEMENT ON PROJECT STATUS**

### **Schedule Overview**

The MUP delay response was submitted by Mortenson and after review and negotiations the MUP impact was agreed to at 87 calendar days. This will shift the Substantial Completion date from December 7, 2005 to March 3, 2006. As the Substantial Completion date is also the Temporary Certificate of Occupancy (TCO) date. This will allow the initial tenants to start moving in furniture and equipment after this date, thereby facilitating Certificate of Occupancy (CO) on March 31, 2006 allowing the programmed tenant start work date of April 3, 2006.

### **Plans for Next 30 Days**

Elevated slab activities are ramping up with projected placement of the first and second levels. Also projected for June is shutting down of dewatering wells and de-tensioning tie-back anchors.

### **Consultant Services**

#### **Accomplishments this Period**

Participated in scope clarification meetings for C&C and assisted in RFP clarifications as they arise.

### **Design Status & Approvals**

The CD set dated February 8, 2005 and issued early March has had numerous design updates issued and an updated CD set was readied for issue at the end of the month. This set will be distributed and reviewed by all UW affected parties.

Validating net assignable square foot (NASF) area of the building with revised drawings was issued by the DBOM for CASPO review. Meetings were held in

May to agree on building area. Current indications are that building NASF will be 650sf smaller than proposed.

**Construction Accomplishments This Period**

The project is officially out of the ground as all slab on grade was placed as were all columns for the lower parking area. Underslab drainage system was also completed. Shoring for elevated slabs was staged with the southwest parking ramp elevated slab erected.

**PROJECT BUDGET & COST**

A preliminary budget was prepared and approved by BOR for the core & shell at \$31,400,000 which included 120 parking stalls. Reduced structured parking to 67 stalls with the remaining 53 to be nearby surface lots has revised the projected core & shell costs to \$29,050,000. This amount does not include improvements for any perimeter surface lots.

The Mortenson proposal indicated they had included \$800,000 of capitalized costs which were amortized over 120 months at 10.8% interest. By the UW buying out this cost and financing it as part of the overall bond issue the University of Washington can realize a potential \$200,000 savings and pass this on to the tenants, further reducing the final lease rate.

By including this \$800,000 into the Core & Shell costs the current budget now stands at \$29,850,000.

Current tax laws may allow some if not most of the building to be tax exempt or tax deferred, the final C&S costs could be below this revised amount. TI costs remain unidentified with an anticipated construction cost of approximately \$20M which will be paid by the tenants. Each tenant improvement will become a separate project and will not be reported here.

**CHANGES IN SCOPE**

One change order request was issued this month which was for the MUP delay.

**BUYOUT STATUS**

As this project is design-build, the mechanical and electrical contractors were part of the selected team. Buying out remaining specialty contractors continues and is not impacting the project.

**OPPORTUNITIES & CHALLENGES**

Coordinating with SCL on undergrounding power lines and identifying costs continues to be a challenging task.

The design-build process is new to the majority of affected parties. Establishing procedures and gaining acceptance will be ongoing.

Identification of tenants in a timely order to take advantage of early design is also a challenge.

**SAFETY STATUS**

Safety Statistics	This Month	Project To Date
Average Daily Work Force	34	31
Lost Time Incidents	0	0
Recordable Incidents	0	0
Total Hours Worked All Crafts	6,698	22,565
Project Total Incidence Rate *	0	0

\* Incidence Rate = (# of Incidents x 200,000 hrs) / (# of hours worked)

## CONSTRUCTION CONTRACT ADMINISTRATION

<b>Change Documents to date</b>	<b>Number</b>	<b>Value</b>
Change Orders Approved	10	\$ 416,568
Change Order Proposals Pending*	4	\$ 1,912,858
Change Order Requests Pending	3	\$ 202,022
Team Change Memos Approved	0	0

\*includes open field work orders

<b>Requests for Information to date</b>	<b>Number</b>	<b>Avg. Turnaround</b>
RFI's	N/A-Design-Build	0 days
<b>Submittals to date</b>	<b>Number</b>	<b>Avg. Turnaround</b>
Submittals	N/A-Design-Build	0 days







Project No. 10297  
Project: 10297 Research & Technology Building

PROJECT COST REPORT - Level 2

	A	B	C	D	E (B+D)	F	G	H	I	J	K(E-J)
	Original Budget	Latest Approved Budget	Unfunded Changes	Funded Changes	Forecast Budget	Committed to Date	Actual Cost to Date	Approved Changes	Pending Changes	Forecast Total Costs	Variance from Fcst Budget
<b>B. Consultant Services</b>											
Pre-Design Services	444,729	440,000	0	0	440,000	493,968	468,273	27,847	0	493,968	(53,968)
Basic Services	412,881	400,000	0	0	400,000	178,000	178,000	178,000	0	178,000	222,000
Extra Services	51,048	50,000	0	0	50,000	219,509	115,816	212,383	0	219,509	(169,509)
Other Services	24,221	120,000	0	0	120,000	132,529	66,702	78,231	0	232,306	(112,306)
Design Services Contingency	48,074	50,500	0	0	50,500	0	0	0	0	0	50,500
<b>Total B. Consultant Services</b>	<b>980,953</b>	<b>1,060,500</b>	<b>0</b>	<b>0</b>	<b>1,060,500</b>	<b>1,024,007</b>	<b>828,791</b>	<b>496,460</b>	<b>0</b>	<b>1,123,783</b>	<b>(63,283)</b>
<b>C. Construction</b>											
Prime Contract	20,119,280	21,102,941	0	0	21,102,941	21,172,101	8,486,925	0	0	21,172,101	(69,160)
Other	0	0	0	0	0	10,359	10,359	0	0	10,359	(10,359)
GC/CM Items	3,669,581	735,294	0	0	735,294	864,000	0	864,000	0	735,294	0
Other Contingency	1,005,964	1,055,147	0	0	1,055,147	734,163	52,538	734,163	865,880	1,594,978	(539,831)
Construction Sales Tax	2,235,060	2,107,471	0	0	2,107,471	1,886,462	383,306	0	0	2,107,471	0
Management Reserve	603,579	1,055,147	0	0	1,055,147	110,000	0	110,000	0	294,144	761,003
<b>Total C. Construction</b>	<b>27,633,464</b>	<b>26,056,000</b>	<b>0</b>	<b>0</b>	<b>26,056,000</b>	<b>24,777,085</b>	<b>8,933,128</b>	<b>1,708,163</b>	<b>865,880</b>	<b>25,914,347</b>	<b>141,653</b>
<b>D. Equipment</b>											
Equipment	0	0	0	0	0	2,952	2,836	0	0	2,952	(2,952)
Furnishings	0	0	0	0	0	0	0	0	0	0	0
Equipment/Furnishings Sales Tax	0	0	0	0	0	0	0	0	0	0	0
<b>Total D. Equipment</b>	<b>0</b>	<b>0</b>	<b>0</b>	<b>0</b>	<b>0</b>	<b>2,952</b>	<b>2,836</b>	<b>0</b>	<b>0</b>	<b>2,952</b>	<b>(2,952)</b>
<b>E. Artwork</b>											
Artwork	95,523	105,515	0	0	105,515	0	0	0	0	0	105,515
<b>Total E. Artwork</b>	<b>95,523</b>	<b>105,515</b>	<b>0</b>	<b>0</b>	<b>105,515</b>	<b>0</b>	<b>0</b>	<b>0</b>	<b>0</b>	<b>0</b>	<b>105,515</b>
<b>F. Other Costs</b>											
In-Plant Services	30,983	27,741	0	0	27,741	387	387	0	0	27,741	0
Utilities/Temporary Facilities	0	0	0	0	0	0	0	0	0	0	0
Permits	227,804	271,634	0	0	271,634	104,427	104,427	0	0	157,272	114,362
Builders Risk Insurance	25,813	25,000	0	0	25,000	0	0	0	0	25,000	0
Other Costs	820,842	625,500	0	0	625,500	435,968	435,968	0	0	911,273	(285,773)
<b>Total F. Other Costs</b>	<b>1,105,442</b>	<b>949,875</b>	<b>0</b>	<b>0</b>	<b>949,875</b>	<b>540,781</b>	<b>540,781</b>	<b>0</b>	<b>0</b>	<b>1,121,286</b>	<b>(171,411)</b>
<b>G. Project Management</b>											
CPO Management	1,146,618	1,075,110	0	0	1,075,110	1,075,110	564,433	0	0	1,075,110	0
Other Management	438,000	603,000	0	0	603,000	305,488	79,858	7,432	0	610,432	(7,432)
Other Costs	0	0	0	0	0	2,090	0	0	0	2,090	(2,090)
<b>Total G. Project Management</b>	<b>1,584,618</b>	<b>1,678,110</b>	<b>0</b>	<b>0</b>	<b>1,678,110</b>	<b>1,382,688</b>	<b>644,291</b>	<b>7,432</b>	<b>0</b>	<b>1,687,632</b>	<b>(9,522)</b>
<b>Project Totals</b>	<b>31,400,000</b>	<b>29,850,000</b>	<b>0</b>	<b>0</b>	<b>29,850,000</b>	<b>27,727,513</b>	<b>10,949,828</b>	<b>2,212,055</b>	<b>865,880</b>	<b>29,850,000</b>	<b>0</b>



*Charles*

*Commons*

*Appendix B*

## Flat-Plate E-TABS Diagrams

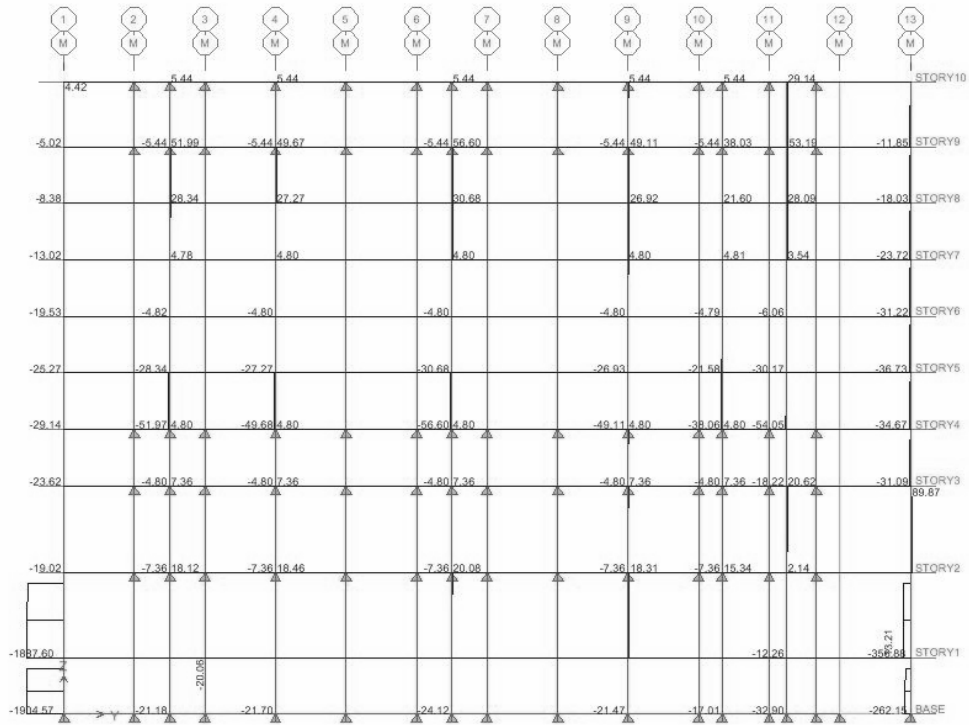

## East Elevation Axial Loads

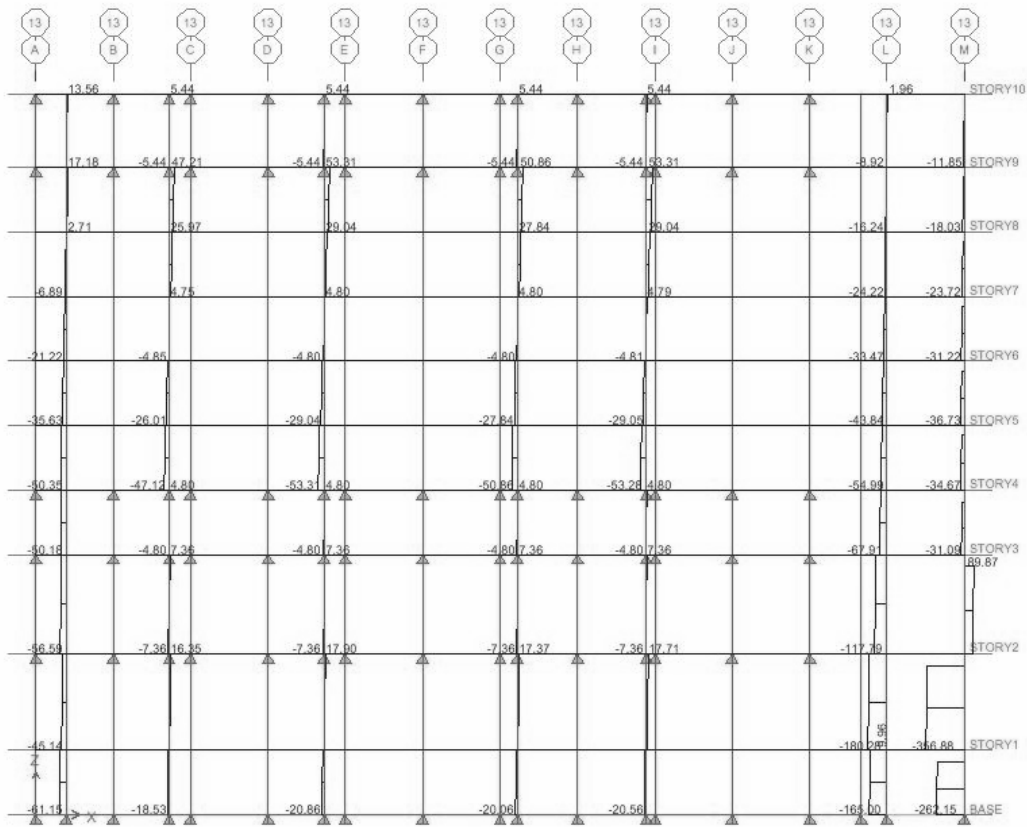

## North Elevation Axial Loads

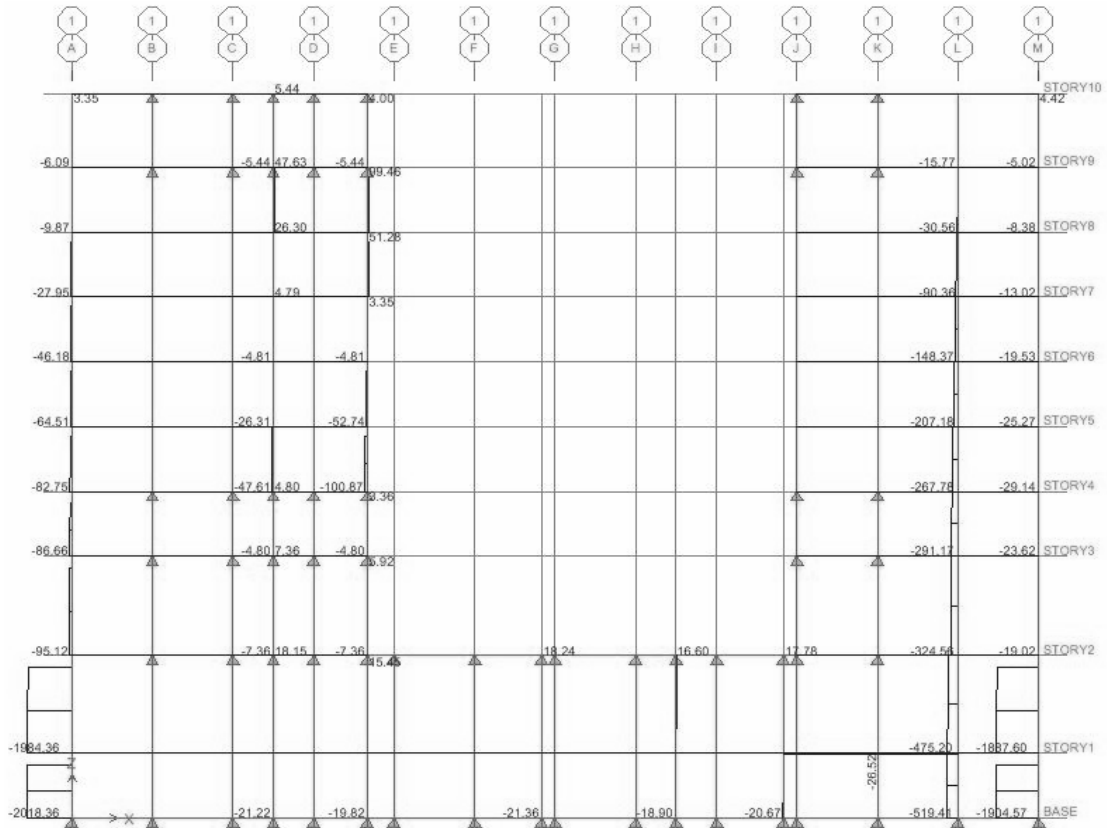

*South Elevation Axial Loads*

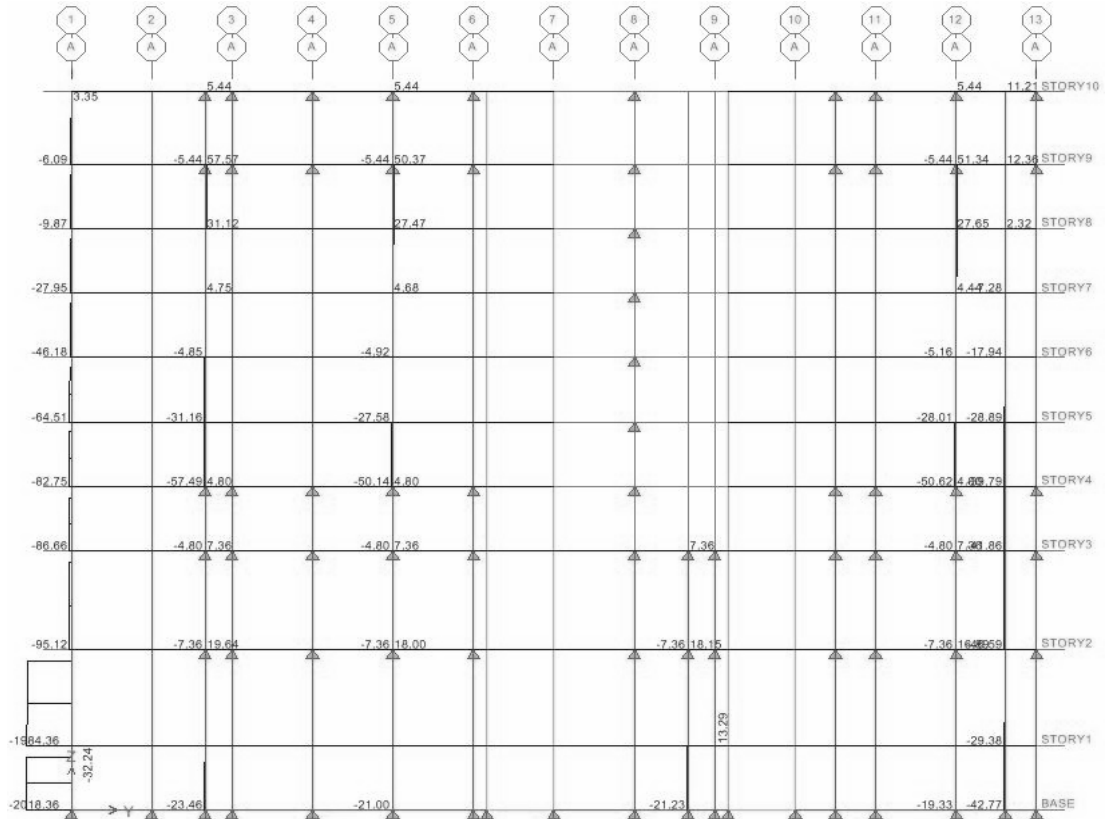

*West Elevation Axial Loads*

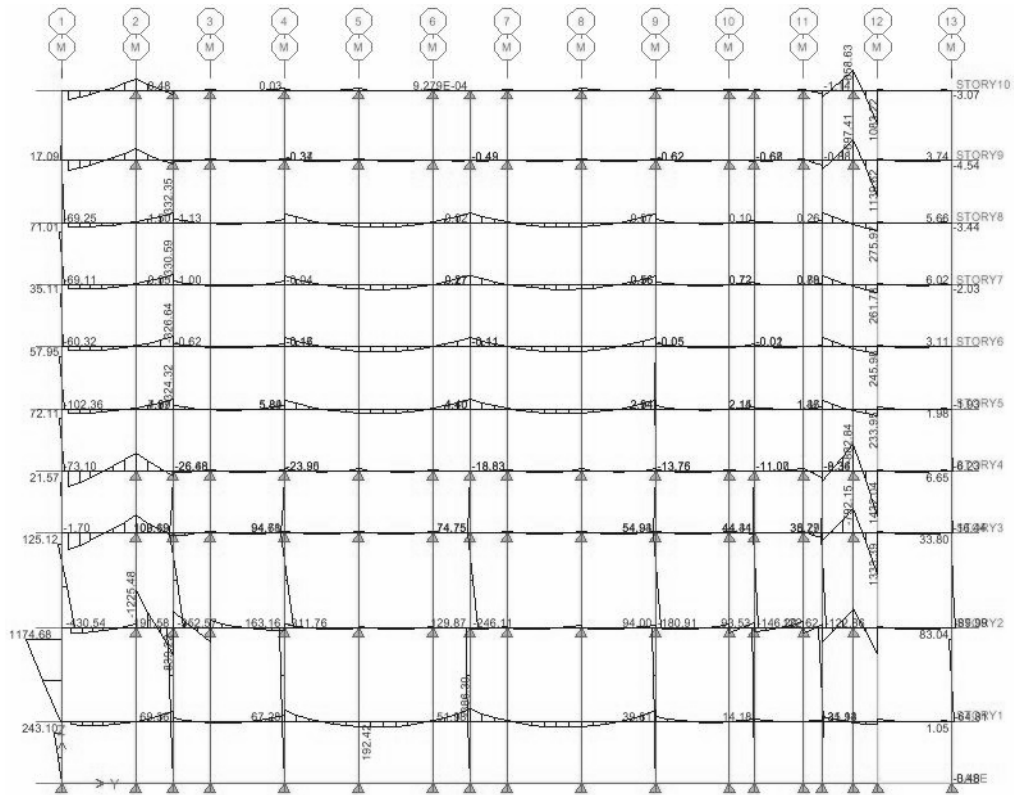

*East Elevation Moment Diagrams*

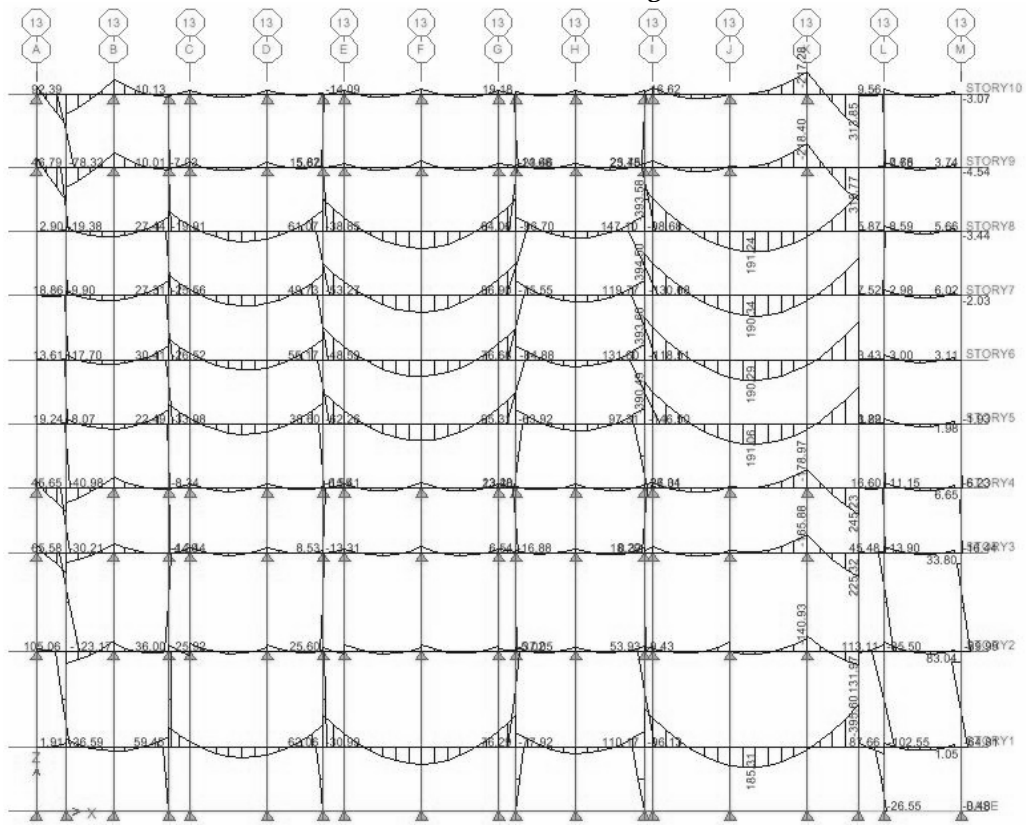

*North Elevation Moment Diagrams*





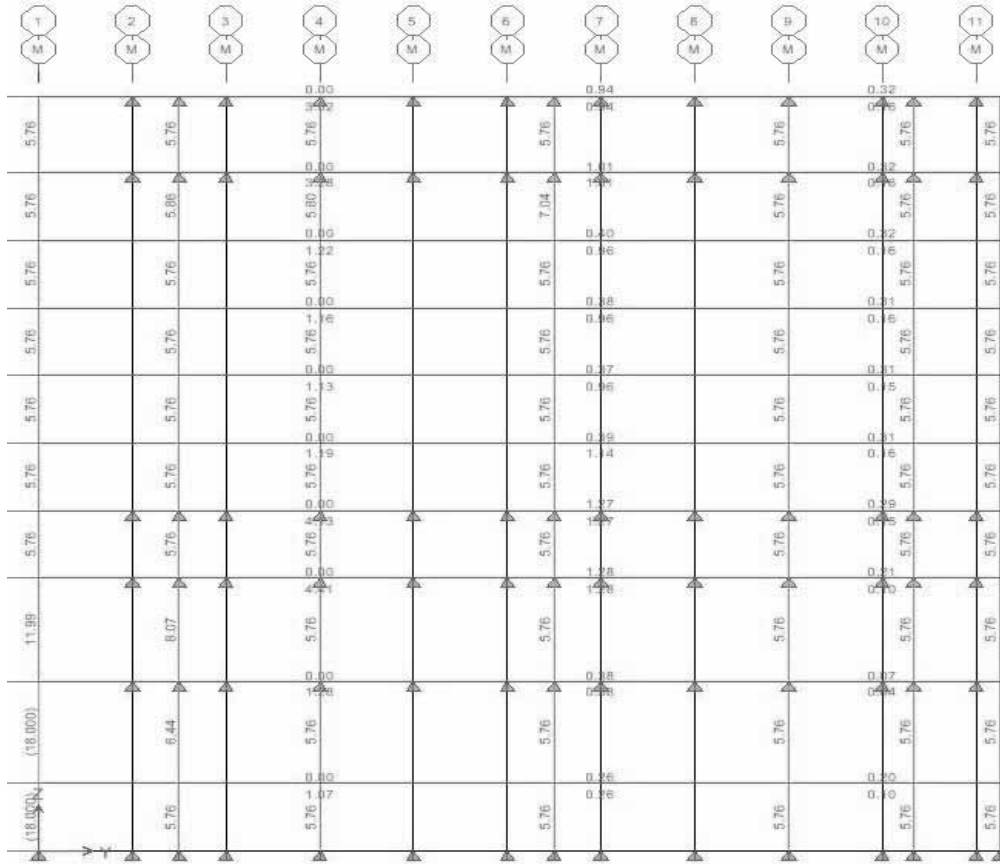

*East Elevation Longitudinal Reinforcing*

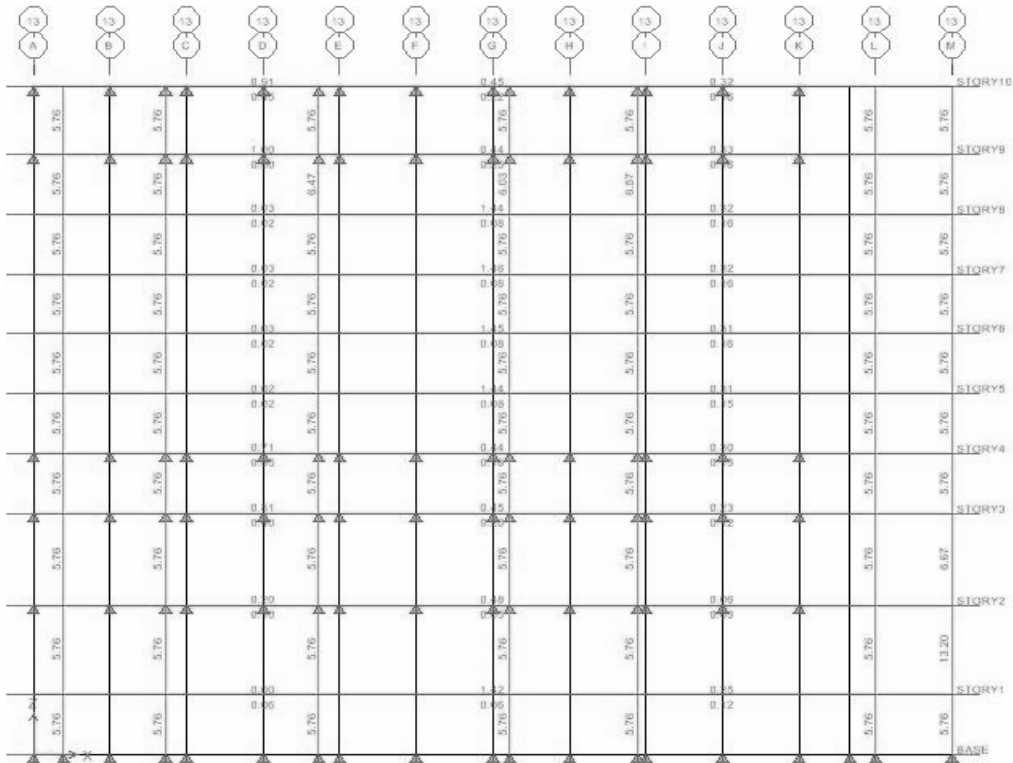

*North Elevation Longitudinal Reinforcing*

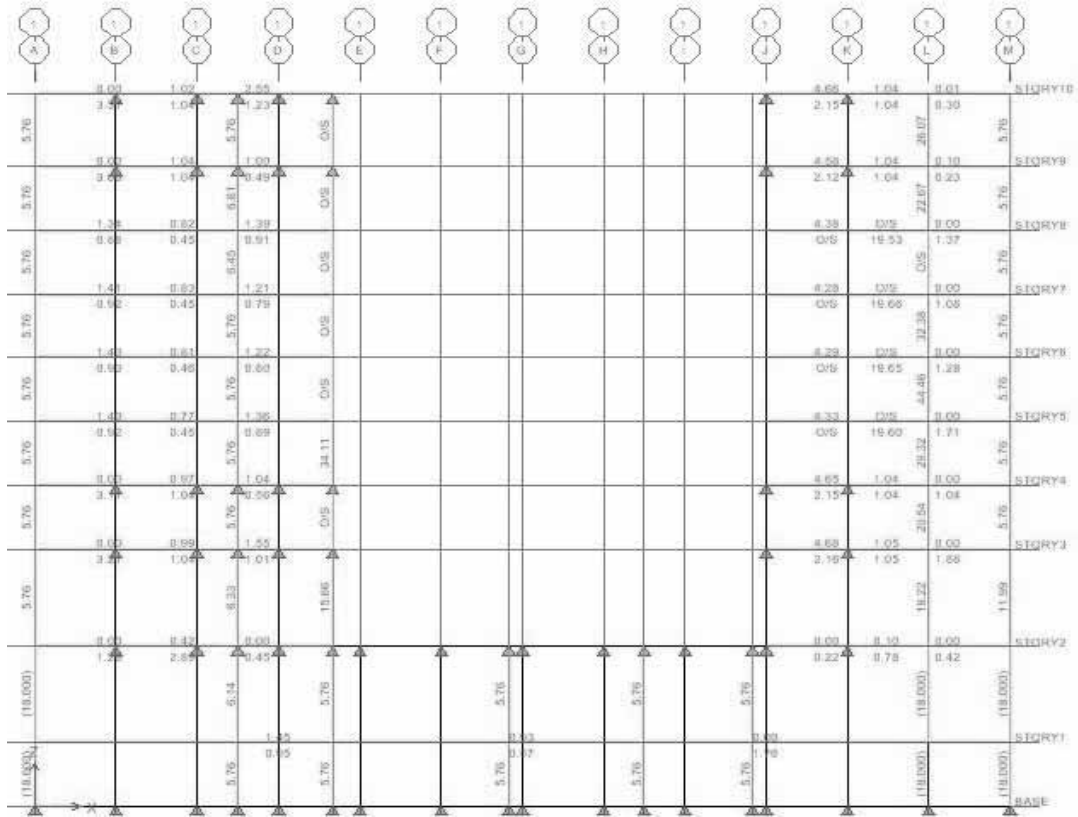

*South Elevation Longitudinal Reinforcing*

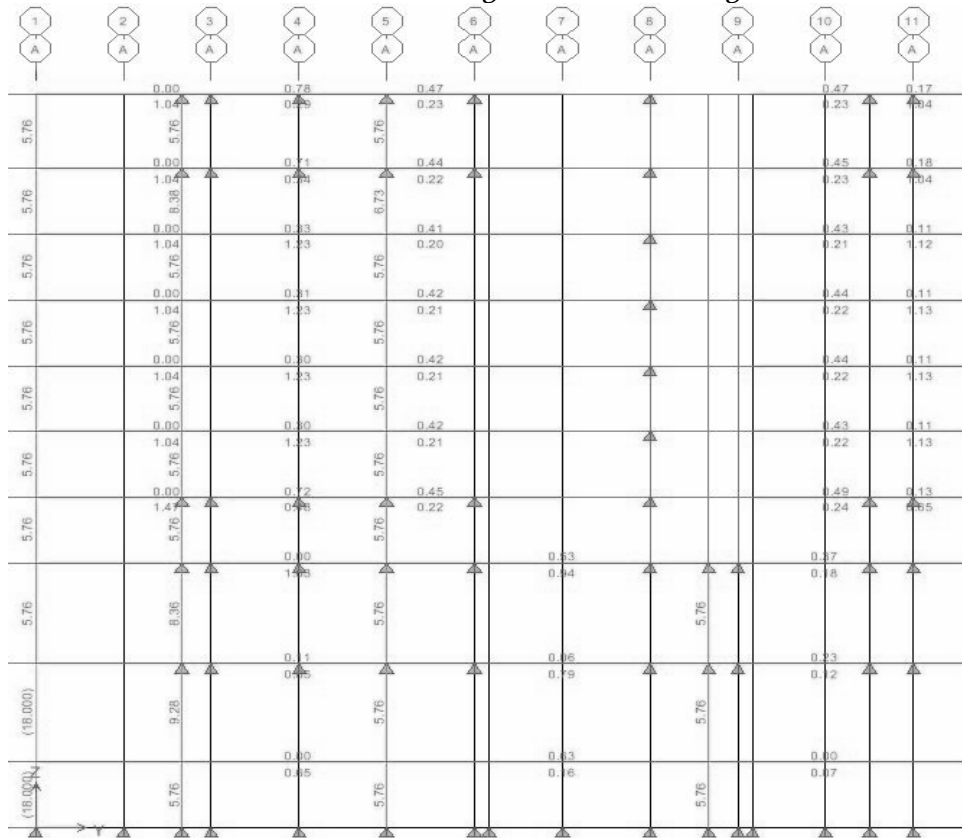

*West Elevation Longitudinal Reinforcing*

## One-Way Beams E-TABS Diagrams

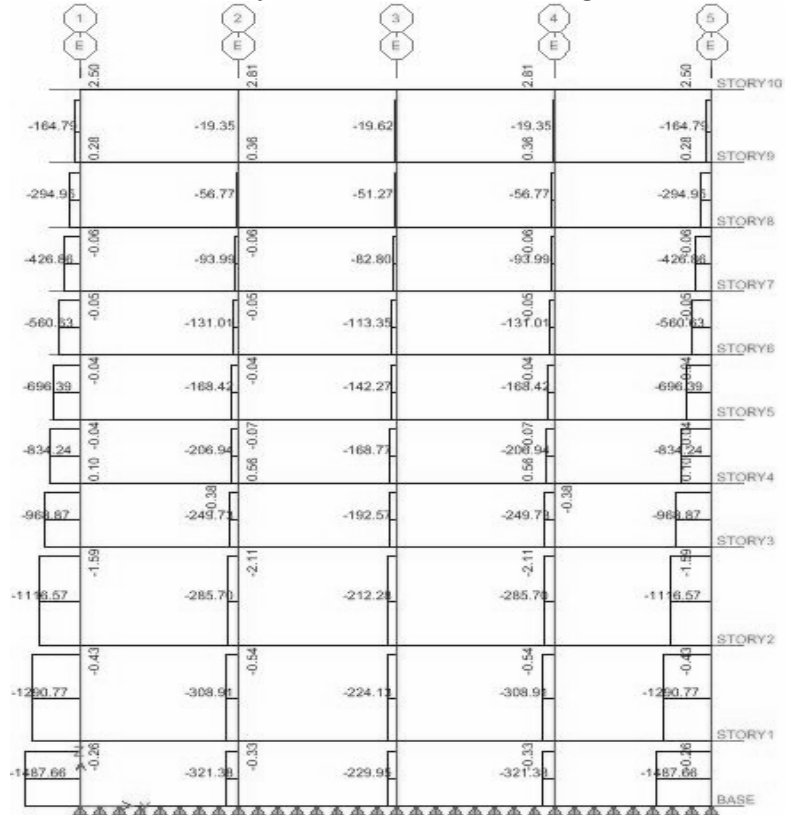

*East Elevation Axial Loads*

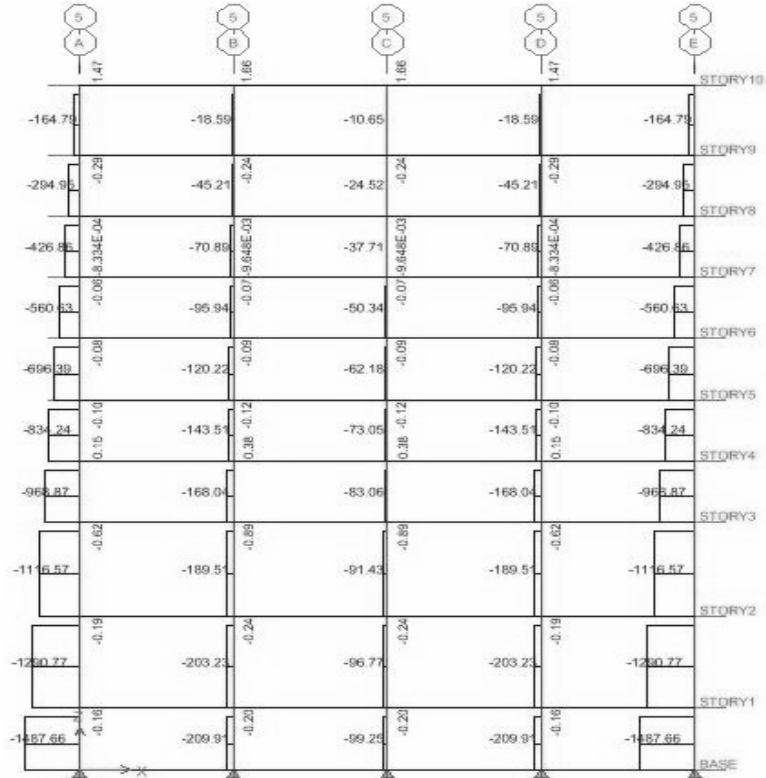

*North Elevation Axial Loads*

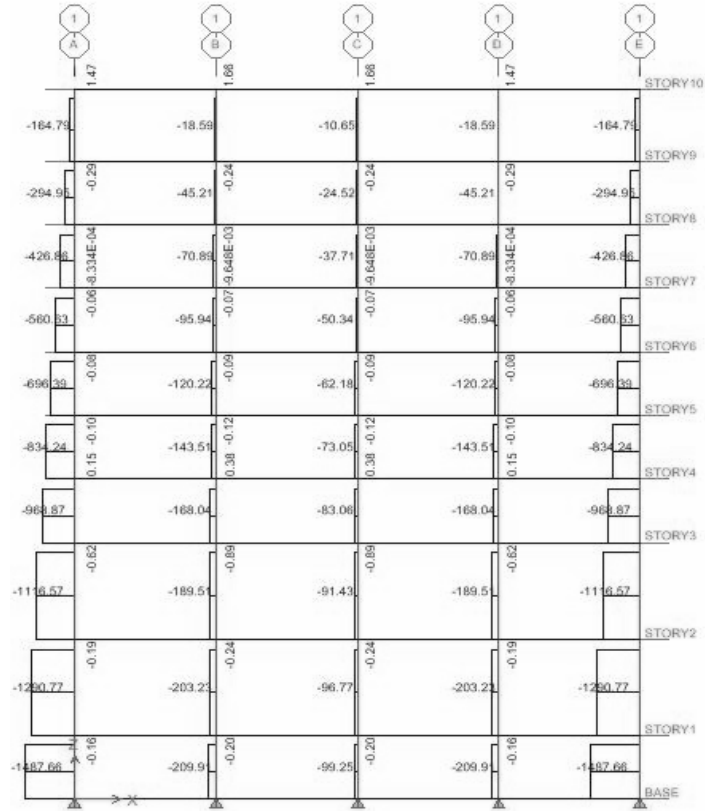

*South Elevation Axial Loads*

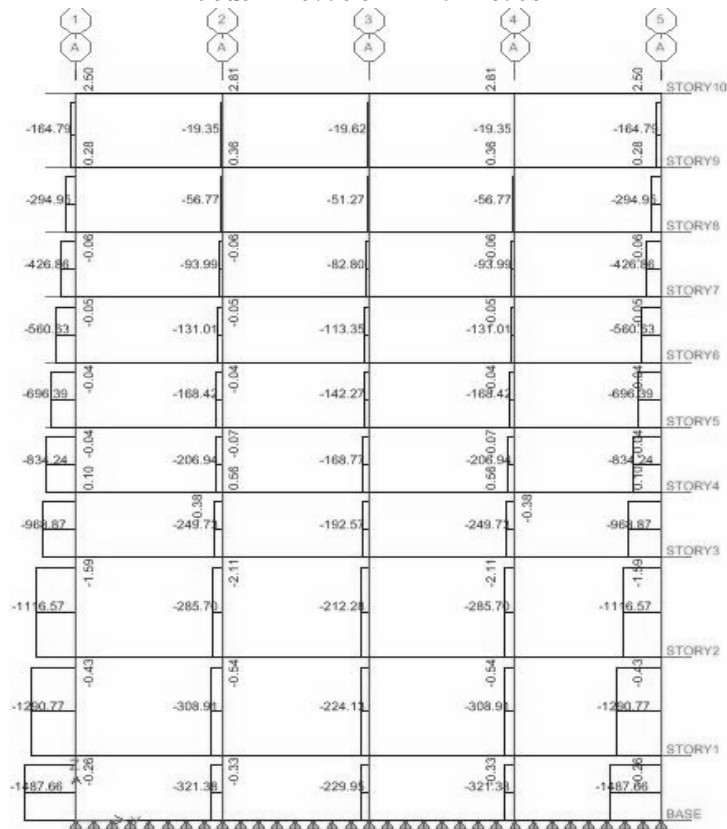

*West Elevation Axial Loads*



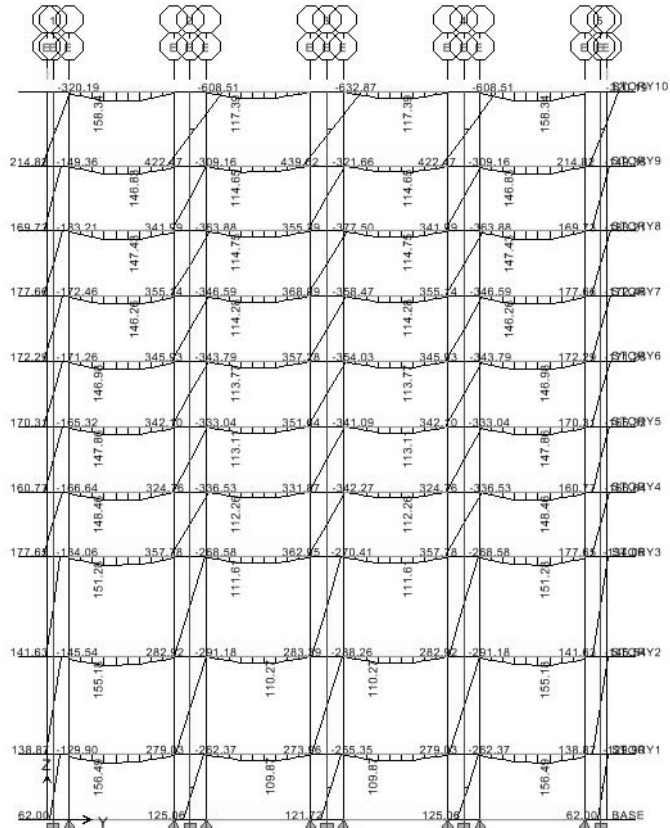

*East Elevation Moment Diagram*

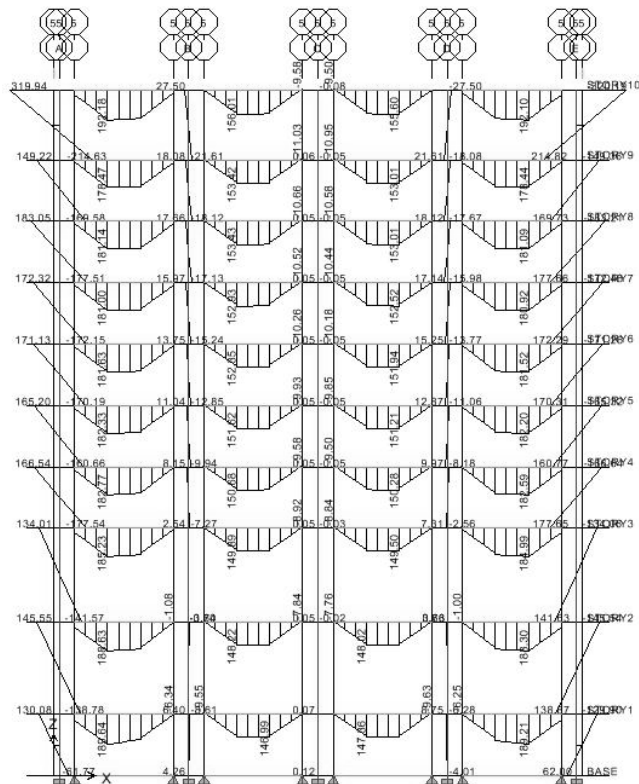

*North Elevation Moment Diagram*

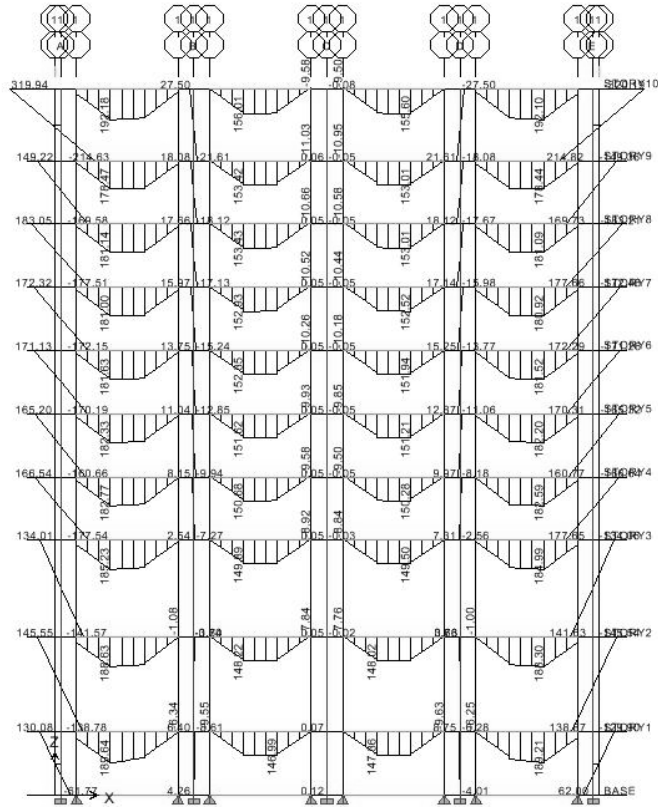

South Elevation Moment Diagram

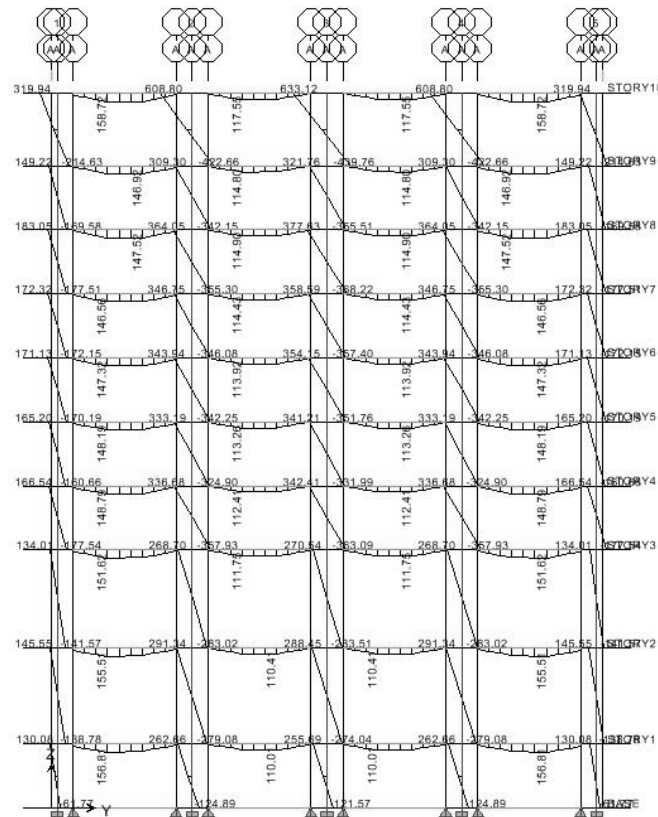

West Elevation Moment Diagram

	1	2	3	4	5
23.70	0.06 0.13 0.53 0.03 0.36 0.26	0.38 0.13 0.54 0.19 0.22 0.27	0.54 0.13 0.38 0.27 0.13 0.19	0.53 0.22 0.06 0.26 0.13 0.03	STORY10
21.67	0.04 0.21 0.70 0.02 0.66 0.43	0.58 0.18 0.70 0.29 0.28 0.37	0.70 0.18 0.58 0.37 0.18 0.29	0.70 0.33 0.04 0.43 0.21 0.02	STORY9
19.36	0.04 0.22 0.70 0.02 0.65 0.43	0.57 0.18 0.70 0.28 0.28 0.37	0.70 0.18 0.57 0.37 0.18 0.28	0.70 0.33 0.04 0.43 0.22 0.02	STORY8
18.31	0.04 0.21 0.70 0.02 0.65 0.43	0.58 0.18 0.70 0.29 0.26 0.36	0.70 0.18 0.58 0.36 0.18 0.29	0.70 0.33 0.04 0.43 0.21 0.02	STORY7
20.30	0.04 0.21 0.70 0.02 0.65 0.43	0.60 0.17 0.69 0.30 0.22 0.34	0.69 0.17 0.60 0.34 0.17 0.30	0.70 0.33 0.04 0.43 0.21 0.02	STORY6
23.47	0.04 0.22 0.70 0.02 0.66 0.44	0.64 0.16 0.64 0.32 0.23 0.32	0.64 0.16 0.64 0.32 0.16 0.32	0.70 0.33 0.04 0.44 0.22 0.02	STORY5
23.69	0.04 0.18 0.70 0.02 0.70 0.36	0.37 0.10 0.41 0.18 0.15 0.20	0.41 0.10 0.37 0.20 0.16 0.18	0.70 0.33 0.04 0.36 0.18 0.02	STORY4
23.87	0.04 0.16 0.67 0.02 0.60 0.33	0.27 0.09 0.35 0.13 0.13 0.18	0.35 0.09 0.27 0.18 0.13 0.13	0.67 0.30 0.04 0.33 0.16 0.02	STORY3
28.69	0.03 0.11 0.43 0.01 0.39 0.21	0.21 0.06 0.24 0.10 0.07 0.12	0.24 0.06 0.21 0.12 0.10 0.10	0.43 0.19 0.03 0.21 0.11 0.01	STORY2
56.84	0.01 0.06 0.24 0.01 0.22 0.12	0.13 0.03 0.14 0.07 0.04 0.07	0.14 0.03 0.13 0.07 0.07 0.07	0.24 0.10 0.01 0.12 0.06 0.01	STORY1
56.84	0.00 0.01 0.00 0.00 0.01 0.00	0.00 0.01 0.00 0.00 0.01 0.00	0.00 0.01 0.00 0.00 0.01 0.00	0.03 0.01 0.00 0.00 0.01 0.00	BASE

*East Elevation Longitudinal Reinforcing*

	1	2	3	4	5
23.70	0.06 0.12 0.48 0.25 0.13 0.24	0.27 0.09 0.35 0.13 0.09 0.18	0.35 0.09 0.27 0.18 0.09 0.13	0.48 0.12 0.06 0.24 0.13 0.25	STORY10
21.67	0.06 0.14 0.58 0.45 0.17 0.29	0.25 0.09 0.38 0.12 0.09 0.18	0.38 0.09 0.25 0.18 0.09 0.12	0.58 0.14 0.06 0.29 0.17 0.45	STORY9
19.36	0.06 0.14 0.58 0.43 0.16 0.29	0.24 0.09 0.35 0.12 0.09 0.17	0.35 0.09 0.24 0.17 0.09 0.12	0.58 0.14 0.06 0.29 0.16 0.43	STORY8
18.31	0.06 0.14 0.57 0.42 0.16 0.28	0.26 0.08 0.33 0.13 0.08 0.16	0.33 0.08 0.26 0.16 0.08 0.13	0.57 0.14 0.06 0.28 0.16 0.42	STORY7
20.30	0.06 0.14 0.55 0.40 0.16 0.27	0.28 0.07 0.29 0.14 0.07 0.15	0.29 0.07 0.28 0.15 0.07 0.14	0.55 0.14 0.06 0.27 0.16 0.40	STORY6
23.47	0.06 0.13 0.54 0.38 0.16 0.27	0.31 0.08 0.25 0.16 0.08 0.13	0.25 0.08 0.31 0.13 0.08 0.16	0.54 0.13 0.06 0.27 0.16 0.38	STORY5
21.69	0.06 0.14 0.57 0.39 0.14 0.28	0.27 0.07 0.22 0.13 0.07 0.11	0.22 0.07 0.27 0.11 0.07 0.13	0.57 0.14 0.06 0.28 0.14 0.39	STORY4
23.97	0.06 0.13 0.53 0.32 0.13 0.28	0.22 0.06 0.22 0.11 0.06 0.11	0.22 0.06 0.22 0.11 0.06 0.11	0.53 0.13 0.06 0.28 0.13 0.32	STORY3
38.69	0.06 0.10 0.36 0.18 0.12 0.19	0.22 0.05 0.16 0.11 0.07 0.08	0.18 0.05 0.22 0.09 0.07 0.11	0.36 0.10 0.06 0.19 0.12 0.18	STORY2
56.84	0.05 0.07 0.26 0.02 0.11 0.13	0.18 0.04 0.16 0.09 0.09 0.08	0.16 0.04 0.18 0.08 0.09 0.08	0.26 0.07 0.05 0.13 0.11 0.02	STORY1
56.84	0.19 0.05 0.21 0.09 0.10 0.11	0.19 0.05 0.20 0.10 0.10 0.10	0.20 0.05 0.19 0.10 0.10 0.10	0.21 0.05 0.19 0.11 0.10 0.09	BASE

*North Elevation Longitudinal Reinforcing*

	1	1	1	1	1	
	A	B	C	D	E	
	0.00 0.12 0.48	0.27 0.09 0.35	0.35 0.09 0.27	0.48 0.12 0.00		STORY10
23.70	0.25 0.13 0.24	0.13 0.09 0.18	0.18 0.09 0.13	0.24 0.13 0.25		
	5.14		3.24	5.14		
	0.00 0.14 0.58	0.25 0.09 0.36	0.36 0.09 0.25	0.58 0.14 0.00		STORY9
21.07	0.45 0.17 0.29	0.12 0.09 0.18	0.18 0.09 0.12	0.29 0.17 0.45		
	4.69		3.24	4.69		
	0.00 0.14 0.58	0.24 0.09 0.35	0.35 0.09 0.24	0.58 0.14 0.00		STORY8
19.36	0.42 0.16 0.29	0.12 0.09 0.17	0.17 0.09 0.12	0.29 0.16 0.43		
	3.98		3.24	3.98		
	0.00 0.14 0.57	0.28 0.08 0.33	0.33 0.08 0.28	0.57 0.14 0.00		STORY7
18.31	0.42 0.16 0.28	0.13 0.08 0.16	0.16 0.08 0.13	0.28 0.16 0.42		
	3.29		3.24	3.29		
	0.00 0.14 0.55	0.28 0.07 0.29	0.29 0.07 0.28	0.55 0.14 0.00		STORY6
20.30	0.40 0.16 0.27	0.14 0.07 0.15	0.15 0.07 0.14	0.27 0.16 0.40		
	3.24		3.24	3.24		
	0.00 0.13 0.54	0.31 0.08 0.25	0.25 0.08 0.31	0.54 0.13 0.00		STORY5
23.47	0.38 0.16 0.27	0.16 0.08 0.13	0.13 0.08 0.16	0.27 0.16 0.38		
	3.24		3.24	3.24		
	0.00 0.14 0.57	0.27 0.07 0.22	0.22 0.07 0.27	0.57 0.14 0.00		STORY4
23.69	0.39 0.14 0.28	0.13 0.07 0.11	0.11 0.07 0.13	0.28 0.14 0.39		
	5.78		5.78	5.78		
	0.00 0.13 0.53	0.22 0.06 0.22	0.22 0.06 0.22	0.53 0.13 0.00		STORY3
23.97	0.32 0.13 0.26	0.11 0.06 0.11	0.11 0.06 0.11	0.26 0.13 0.32		
	5.78		5.78	5.78		
	0.00 0.10 0.35	0.22 0.05 0.18	0.18 0.05 0.22	0.35 0.10 0.00		STORY2
38.09	0.16 0.12 0.19	0.11 0.07 0.09	0.09 0.07 0.11	0.19 0.12 0.16		
	5.78		5.78	5.78		
	0.05 0.07 0.26	0.18 0.04 0.16	0.16 0.04 0.18	0.26 0.07 0.05		STORY1
56.84	0.02 0.11 0.13	0.09 0.06 0.08	0.08 0.06 0.09	0.13 0.11 0.02		
	5.78		5.78	5.78		
	0.19 0.05 0.21	0.19 0.05 0.20	0.20 0.05 0.19	0.21 0.05 0.19		BASE
	0.09 0.10 0.11	0.10 0.10 0.10	0.10 0.10 0.10	0.11 0.10 0.09		

*South Elevation Longitudinal Reinforcing*

	1	2	3	4	5	
	A	B	C	D	E	
	0.06 0.11 0.53	0.38 0.13 0.54	0.54 0.13 0.38	0.53 0.22 0.06		STORY10
23.70	0.03 0.35 0.28	0.19 0.22 0.27	0.27 0.13 0.19	0.28 0.13 0.03		
	3.24		3.24	3.24		
	0.04 0.21 0.70	0.58 0.18 0.70	0.70 0.18 0.58	0.70 0.33 0.04		STORY9
21.07	0.02 0.66 0.43	0.29 0.28 0.37	0.37 0.18 0.29	0.43 0.21 0.02		
	3.24		3.24	3.24		
	0.04 0.22 0.70	0.57 0.18 0.70	0.70 0.18 0.57	0.70 0.33 0.04		STORY8
19.36	0.02 0.65 0.43	0.28 0.28 0.37	0.37 0.18 0.28	0.43 0.22 0.02		
	3.24		3.24	3.24		
	0.04 0.21 0.70	0.58 0.18 0.70	0.70 0.18 0.58	0.70 0.33 0.04		STORY7
18.31	0.02 0.65 0.43	0.29 0.28 0.36	0.36 0.18 0.29	0.43 0.21 0.02		
	3.24		3.24	3.24		
	0.04 0.21 0.70	0.60 0.17 0.60	0.60 0.17 0.60	0.70 0.33 0.04		STORY6
20.30	0.02 0.65 0.43	0.30 0.22 0.34	0.34 0.17 0.30	0.43 0.21 0.02		
	3.24		3.24	3.24		
	0.04 0.22 0.70	0.64 0.16 0.64	0.64 0.16 0.64	0.70 0.33 0.04		STORY5
23.47	0.02 0.66 0.44	0.32 0.25 0.32	0.32 0.16 0.32	0.44 0.22 0.02		
	3.24		3.24	3.24		
	0.04 0.18 0.70	0.37 0.10 0.41	0.41 0.10 0.37	0.70 0.35 0.04		STORY4
23.69	0.02 0.70 0.38	0.18 0.15 0.20	0.20 0.16 0.18	0.38 0.18 0.02		
	5.78		5.78	5.78		
	0.04 0.16 0.67	0.27 0.09 0.35	0.35 0.09 0.27	0.67 0.30 0.04		STORY3
23.97	0.02 0.69 0.33	0.13 0.13 0.18	0.18 0.13 0.13	0.33 0.16 0.02		
	5.78		5.78	5.78		
	0.03 0.11 0.43	0.21 0.08 0.24	0.24 0.08 0.21	0.43 0.10 0.03		STORY2
38.09	0.01 0.39 0.21	0.10 0.07 0.12	0.12 0.10 0.10	0.21 0.11 0.01		
	5.78		5.78	5.78		
	0.01 0.08 0.24	0.13 0.03 0.14	0.14 0.03 0.13	0.24 0.10 0.01		STORY1
56.84	0.01 0.23 0.12	0.07 0.04 0.07	0.07 0.07 0.07	0.12 0.08 0.01		
	5.78		5.78	5.78		
	0.03 0.01 0.03	0.00 0.01 0.00	0.00 0.01 0.00	0.03 0.01 0.00		BASE

*West Elevation Longitudinal Reinforcing*

## Precast Plank E-TABS Diagrams

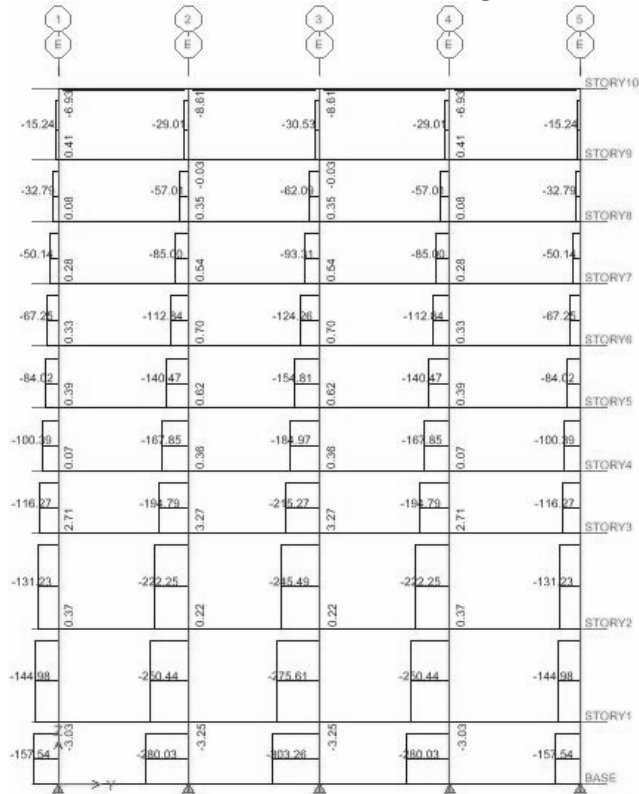

*East Elevation Axial Loads*

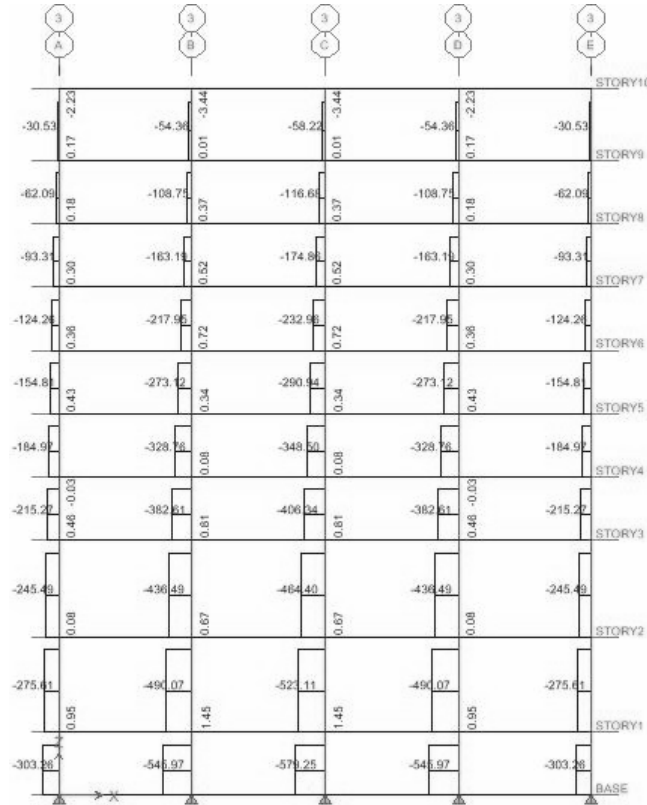

*North Elevation Axial Loads*

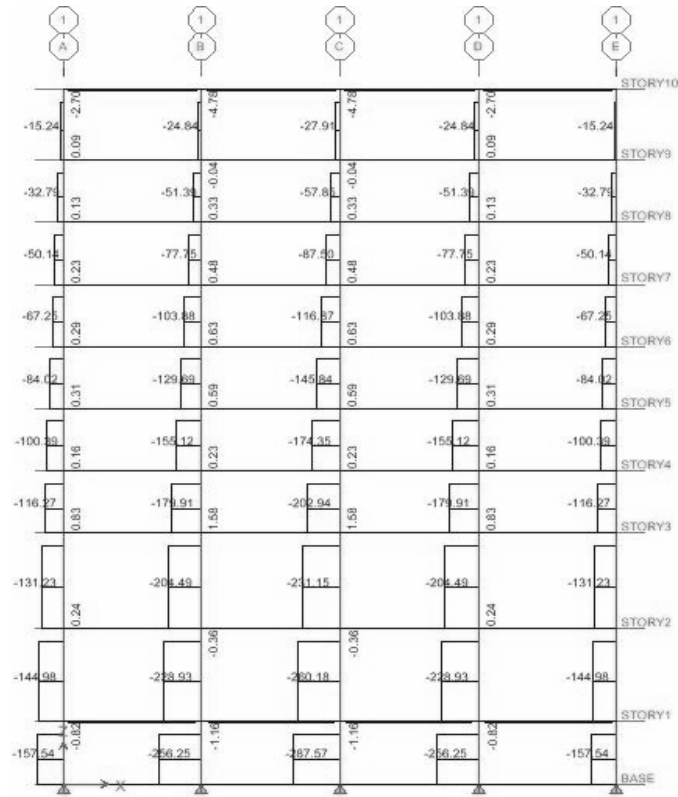

*South Elevation Axial Loads*

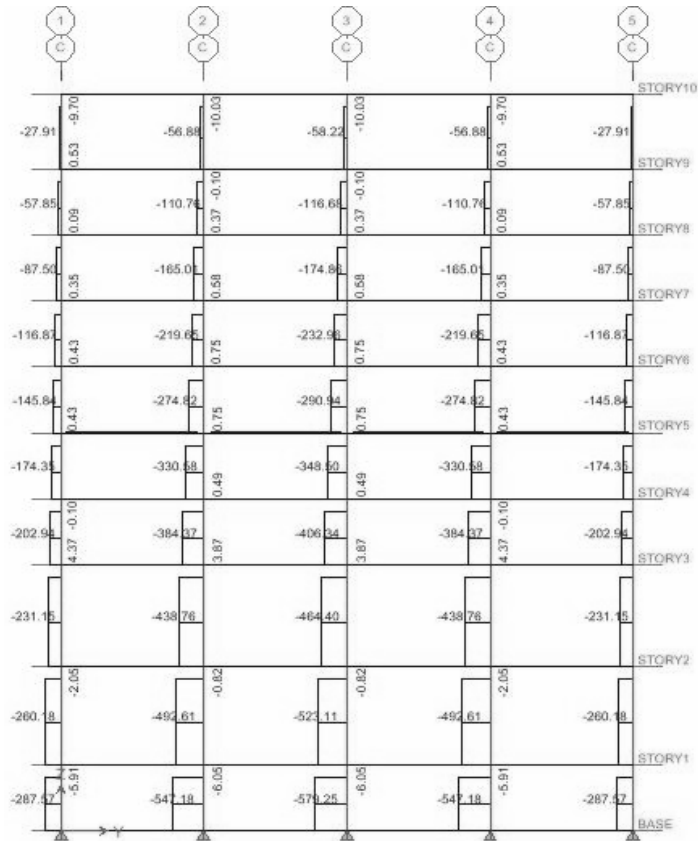

*West Elevation Axial Loads*



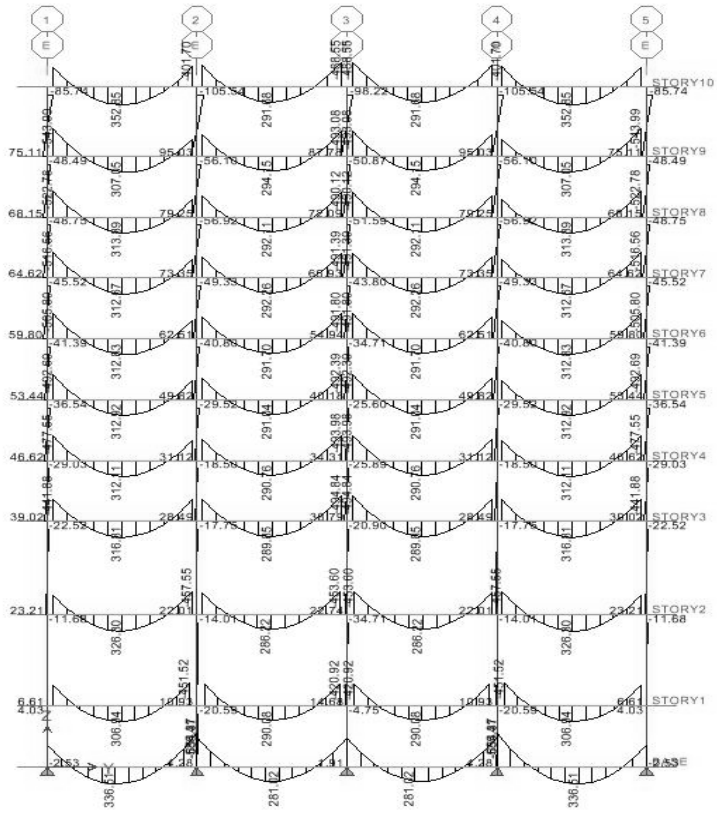

*East Elevation Moment Diagram*

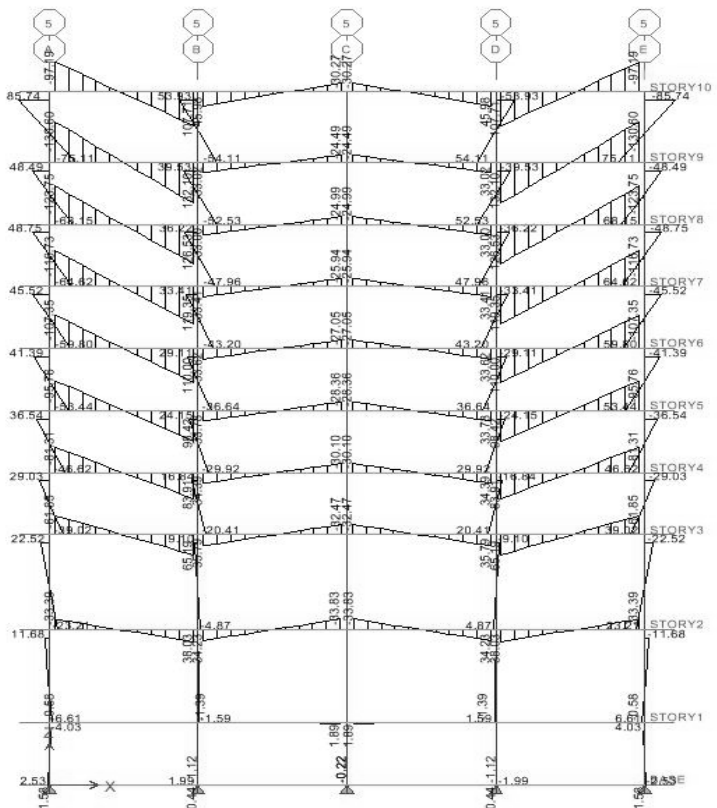

*North Elevation Moment Diagram*

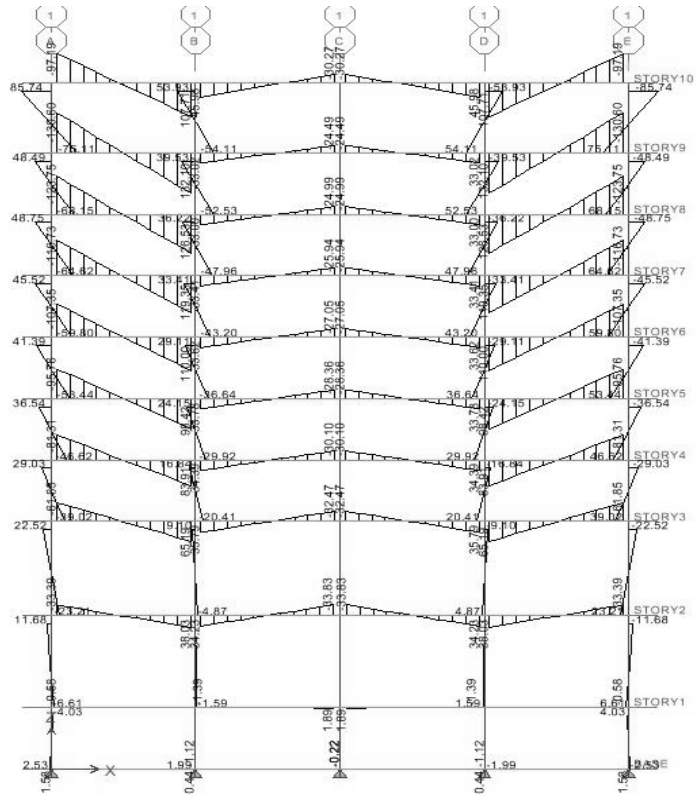

*South Elevation Moment Diagram*

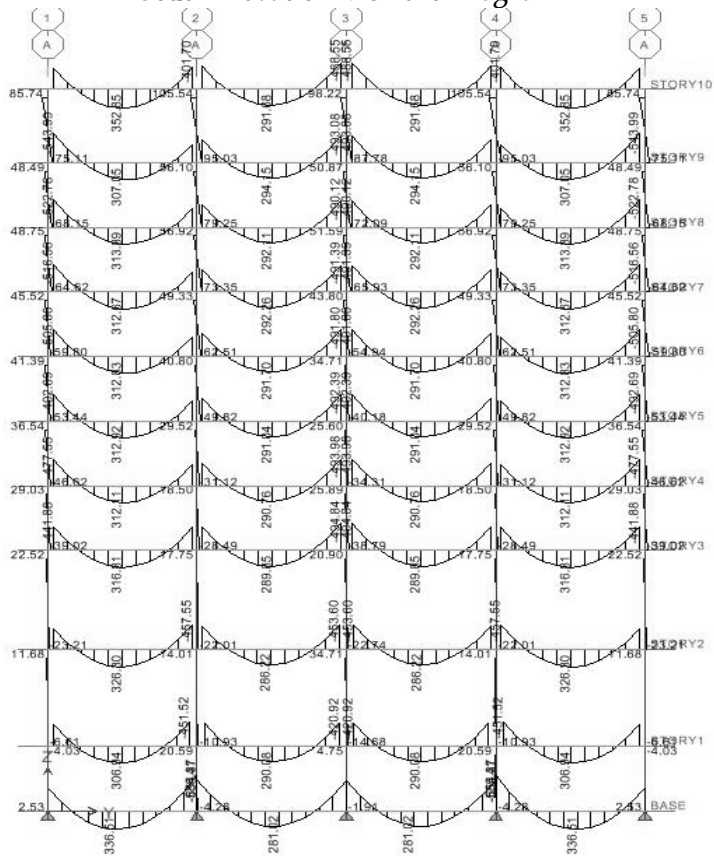

*West Elevation Moment Diagram*

	1	2	3	4	5	
	1.21 0.30 1.19	1.47 0.50 1.80	1.80 0.50 1.47	1.18 0.30 1.21		STORY10
3.44	0.60 1.80 0.59	0.73 1.70 1.02	1.02 1.70 0.73	0.59 1.80 0.60		
	1.80 0.56 0.80	1.36 0.52 1.80	1.80 0.52 1.36	0.80 0.56 1.80		STORY9
3.24	1.13 1.80 0.40	0.68 1.71 1.04	1.04 1.71 0.68	0.40 1.80 1.13		
	1.80 0.54 0.84	1.41 0.51 1.80	1.80 0.51 1.41	0.84 0.54 1.80		STORY8
3.24	1.05 1.80 0.42	0.70 1.70 1.03	1.03 1.70 0.70	0.42 1.80 1.05		
	1.80 0.53 0.90	1.41 0.52 1.80	1.80 0.52 1.41	0.90 0.53 1.80		STORY7
3.24	1.06 1.80 0.45	0.70 1.70 1.04	1.04 1.70 0.70	0.45 1.80 1.06		
	1.80 0.51 0.95	1.42 0.52 1.80	1.80 0.52 1.42	0.95 0.51 1.80		STORY6
3.24	1.02 1.80 0.48	0.70 1.68 1.05	1.05 1.68 0.70	0.48 1.80 1.02		
	1.80 0.48 1.09	1.43 0.52 1.80	1.80 0.52 1.43	1.09 0.48 1.80		STORY5
3.24	0.96 1.80 0.54	0.71 1.69 1.06	1.06 1.69 0.71	0.54 1.80 0.96		
	1.80 0.45 1.23	1.42 0.54 1.80	1.80 0.54 1.42	1.23 0.45 1.80		STORY4
3.24	0.91 1.80 0.61	0.70 1.68 1.08	1.08 1.68 0.70	0.61 1.80 0.91		
	1.52 0.37 1.44	1.44 0.54 1.80	1.80 0.54 1.44	1.44 0.37 1.52		STORY3
3.24	0.75 1.80 0.72	0.71 1.66 1.10	1.10 1.66 0.71	0.72 1.80 0.75		
	1.10 0.42 1.72	1.54 0.51 1.80	1.80 0.51 1.54	1.72 0.42 1.10		STORY2
3.24	0.54 1.80 0.85	0.76 1.61 1.03	1.03 1.61 0.76	0.85 1.80 0.54		
	1.05 0.50 1.80	1.76 0.43 1.61	1.61 0.43 1.76	1.80 0.50 1.05		STORY1
4.32	0.52 1.75 1.00	0.87 1.61 0.80	0.80 1.61 0.87	1.00 1.75 0.52		
	1.05 0.68 2.13	1.85 0.60 1.80	1.80 0.60 1.85	2.13 0.68 1.05		BASE
4.32	0.52 1.80 1.40	1.21 1.79 1.11	1.11 1.80 1.21	1.40 1.80 0.52		

*East Elevation Longitudinal Reinforcing*

	3	3	3	3	3	
	0.69 0.17 0.03	0.14 0.13 0.51	0.51 0.13 0.14	0.03 0.17 0.69		STORY10
3.24	0.34 0.36 0.42	0.10 0.32 0.26	0.26 0.32 0.10	0.42 0.36 0.34		
	1.15 0.28 0.00	0.15 0.12 0.49	0.49 0.12 0.15	0.00 0.28 1.15		STORY9
3.24	0.57 0.28 0.64	0.07 0.30 0.24	0.24 0.30 0.07	0.64 0.28 0.57		
	1.05 0.26 0.00	0.17 0.12 0.49	0.49 0.12 0.17	0.00 0.26 1.05		STORY8
3.24	0.52 0.29 0.55	0.08 0.29 0.24	0.24 0.29 0.08	0.55 0.29 0.52		
	0.92 0.23 0.04	0.18 0.12 0.49	0.49 0.12 0.18	0.04 0.23 0.92		STORY7
3.24	0.46 0.28 0.42	0.09 0.27 0.25	0.25 0.27 0.09	0.42 0.28 0.46		
	0.74 0.18 0.13	0.20 0.12 0.50	0.50 0.12 0.20	0.13 0.18 0.74		STORY6
3.24	0.37 0.28 0.24	0.10 0.25 0.25	0.25 0.25 0.10	0.24 0.28 0.37		
	0.54 0.14 0.21	0.21 0.11 0.46	0.46 0.11 0.21	0.21 0.14 0.54		STORY5
3.24	0.27 0.27 0.19	0.10 0.21 0.23	0.23 0.21 0.10	0.19 0.27 0.27		
	0.59 0.15 0.18	0.18 0.12 0.49	0.49 0.12 0.18	0.18 0.15 0.59		STORY4
5.11	0.29 0.28 0.12	0.09 0.21 0.24	0.24 0.21 0.09	0.12 0.28 0.29		
	0.56 0.14 0.15	0.17 0.11 0.53	0.53 0.11 0.17	0.15 0.14 0.56		STORY3
9.11	0.28 0.30 0.13	0.08 0.21 0.26	0.26 0.21 0.08	0.13 0.30 0.28		
	0.65 0.16 0.07	0.12 0.14 0.58	0.58 0.14 0.12	0.07 0.16 0.65		STORY2
14.93	0.32 0.29 0.22	0.06 0.22 0.29	0.29 0.22 0.06	0.22 0.29 0.32		
	0.38 0.10 0.25	0.30 0.07 0.27	0.27 0.07 0.30	0.25 0.10 0.38		STORY1
5.76	0.19 0.21 0.13	0.15 0.21 0.13	0.13 0.21 0.15	0.13 0.21 0.19		
	0.30 0.11 0.45	0.43 0.11 0.40	0.40 0.11 0.43	0.45 0.11 0.30		BASE
5.76	0.15 0.24 0.23	0.21 0.19 0.20	0.20 0.20 0.21	0.23 0.23 0.15		

*North Elevation Longitudinal Reinforcing*

	1	1	1	1	1	
	0.67 0.17 0.05	0.12 0.12 0.50	0.50 0.12 0.12	0.00 0.17 0.67		STORY10
3.44	0.33 0.39 0.38	0.08 0.32 0.25	0.25 0.32 0.08	0.39 0.38 0.33		
	5.11	4.99	5.11			
	1.14 0.28 0.00	0.13 0.12 0.48	0.48 0.12 0.13	0.00 0.28 1.14		STORY9
3.24	0.57 0.29 0.63	0.06 0.30 0.24	0.24 0.30 0.06	0.63 0.28 0.57		
	3.24	3.24	3.24			
	1.10 0.27 0.00	0.14 0.12 0.49	0.49 0.12 0.14	0.00 0.27 1.10		STORY8
3.24	0.54 0.29 0.60	0.07 0.29 0.24	0.24 0.29 0.07	0.60 0.28 0.54		
	3.24	3.24	3.24			
	1.05 0.28 0.00	0.14 0.13 0.51	0.51 0.13 0.14	0.00 0.28 1.05		STORY7
3.24	0.52 0.28 0.55	0.07 0.28 0.25	0.25 0.28 0.07	0.55 0.28 0.52		
	3.24	3.24	3.24			
	0.98 0.24 0.00	0.13 0.13 0.53	0.53 0.13 0.13	0.00 0.24 0.98		STORY6
3.24	0.49 0.25 0.48	0.07 0.27 0.26	0.26 0.27 0.07	0.48 0.25 0.49		
	3.24	4.44	3.24			
	0.89 0.22 0.00	0.13 0.14 0.56	0.56 0.14 0.13	0.00 0.22 0.89		STORY5
3.24	0.44 0.25 0.40	0.07 0.26 0.26	0.26 0.26 0.07	0.40 0.25 0.44		
	3.24	7.10	4.51			
	0.79 0.20 0.02	0.13 0.15 0.60	0.60 0.15 0.13	0.02 0.20 0.79		STORY4
3.24	0.38 0.28 0.30	0.06 0.24 0.30	0.30 0.24 0.06	0.30 0.28 0.38		
	3.24	11.42	7.72			
	0.61 0.15 0.10	0.12 0.16 0.65	0.65 0.16 0.12	0.10 0.15 0.61		STORY3
3.24	0.30 0.30 0.15	0.08 0.22 0.33	0.33 0.22 0.08	0.15 0.30 0.30		
	3.24	11.33	11.33			
	0.36 0.09 0.21	0.14 0.17 0.68	0.68 0.17 0.14	0.21 0.09 0.36		STORY2
3.24	0.18 0.32 0.10	0.07 0.19 0.34	0.34 0.19 0.07	0.10 0.32 0.18		
	3.24	12.09	5.78			
	0.16 0.11 0.43	0.36 0.09 0.26	0.26 0.09 0.36	0.43 0.11 0.16		STORY1
4.51	0.08 0.23 0.21	0.18 0.20 0.13	0.13 0.20 0.18	0.21 0.23 0.08		
	3.24	5.78	6.44			
	0.10 0.12 0.50	0.43 0.11 0.40	0.40 0.11 0.43	0.50 0.12 0.10		BASE
4.51	0.10 0.28 0.25	0.22 0.19 0.20	0.20 0.19 0.22	0.25 0.25 0.10		

*South Elevation Longitudinal Reinforcing*

	1	1	1	1	1	
	1.80 0.89 3.13	2.24 0.91 2.92	2.22 0.91 2.24	2.13 0.89 1.80		STORY10
4.09	0.98 2.76 1.39	1.47 2.39 1.80	1.60 2.39 1.47	1.39 2.76 0.98		
	3.24	3.24	3.24	4.09		
	2.58 0.83 1.60	2.08 0.93 2.88	2.38 0.93 2.09	1.60 0.83 2.58		STORY9
3.24	1.68 2.57 1.16	1.37 2.41 1.80	1.80 2.41 1.37	1.16 2.57 1.68		
	3.24	3.24	3.24	3.24		
	2.48 0.79 1.84	2.14 0.92 2.87	2.67 0.92 2.14	1.84 0.79 2.48		STORY8
3.24	1.80 2.58 1.21	1.40 2.41 1.80	1.80 2.41 1.40	1.21 2.58 1.80		
	3.24	3.24	3.24	3.24		
	2.35 0.78 1.98	2.17 0.92 2.88	2.35 0.92 2.17	1.98 0.78 2.35		STORY7
3.24	1.54 2.58 1.28	1.42 2.40 1.80	1.80 2.40 1.42	1.28 2.58 1.54		
	3.24	8.72	7.33			
	2.20 0.71 2.11	2.20 0.93 2.88	2.68 0.93 2.20	2.11 0.71 2.20		STORY6
3.24	1.44 2.58 1.38	1.44 2.39 1.80	1.80 2.39 1.44	1.38 2.58 1.44		
	3.24	10.34	14.39			
	2.02 0.68 2.09	2.03 0.85 2.85	2.65 0.85 2.03	2.09 0.68 2.02		STORY5
3.24	1.32 2.53 1.37	1.33 2.30 1.73	1.73 2.30 1.33	1.37 2.53 1.32		
	3.24	5.78	5.78			
	2.05 0.65 2.10	1.98 0.67 2.88	2.68 0.67 2.05	2.10 0.65 2.05		STORY4
11.42	1.34 2.52 1.37	1.30 2.30 1.75	1.75 2.30 1.30	1.37 2.52 1.34		
	3.24	12.48	12.48			
	1.63 0.70 2.15	1.98 0.67 2.71	2.71 0.67 1.98	2.15 0.70 1.63		STORY3
14.84	1.20 2.58 1.41	1.30 2.30 1.76	1.76 2.30 1.30	1.41 2.58 1.20		
	3.24	19.48	19.48			
	1.99 0.65 1.97	1.93 0.84 2.61	2.61 0.84 1.93	1.97 0.65 1.99		STORY2
5.78	1.30 2.47 1.29	1.27 2.27 1.70	1.70 2.27 1.27	1.29 2.47 1.30		
	3.24	20.87	20.87			
	2.23 0.72 2.19	2.11 0.77 2.98	2.39 0.77 2.11	2.19 0.72 2.23		STORY1
8.44	1.46 2.36 1.43	1.38 2.39 1.58	1.58 2.39 1.38	1.43 2.36 1.46		
	3.24	34.02	34.02			
	2.26 1.16 3.66	3.37 1.07 3.19	3.19 1.07 3.37	3.66 1.16 2.26		BASE
8.44	1.45 3.60 1.60	1.60 2.61 1.60	1.60 2.62 1.60	1.60 3.74 1.47		

*West Elevation Longitudinal Reinforcing*

## *4-D Structural Sequencing*

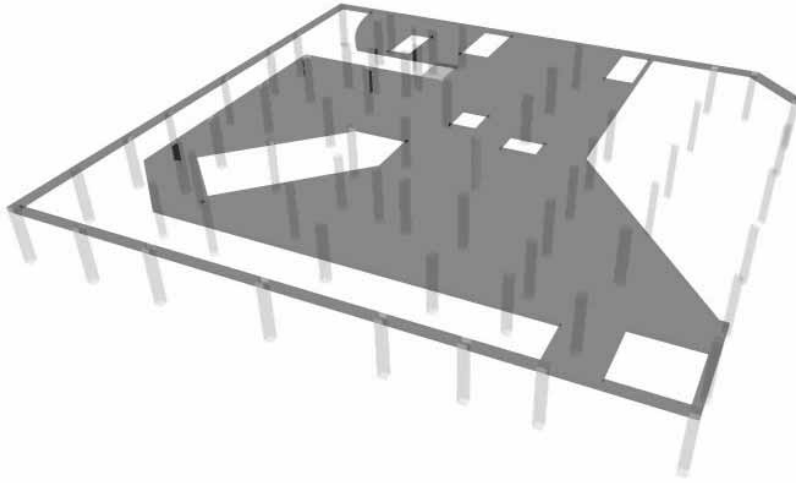

*Day 5*

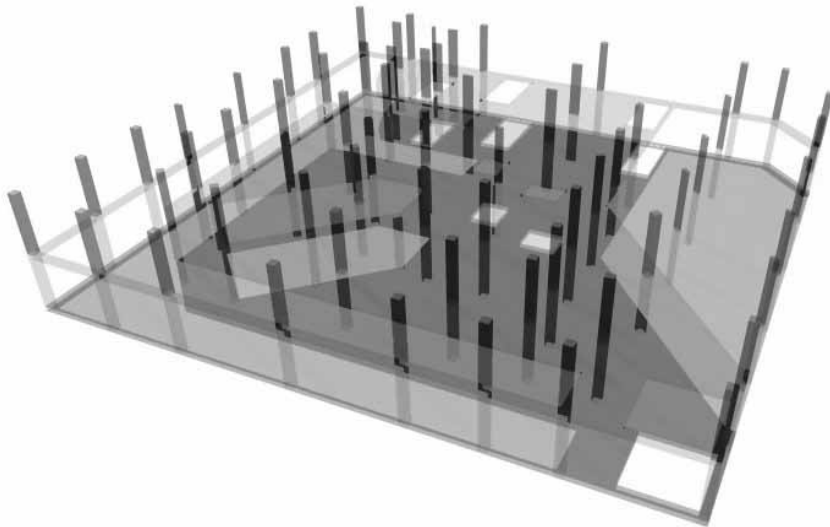

*Day 17*

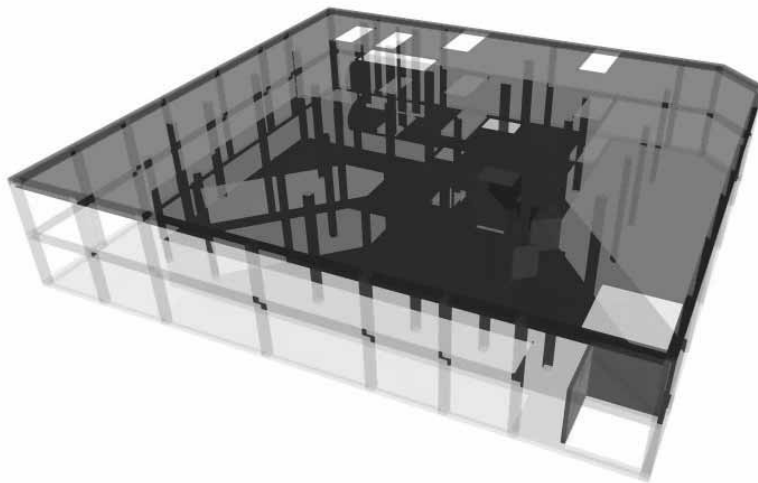

*Day 26*



*Charles*

*Commons*

*Appendix C*



*4-D MEP Sequencing*

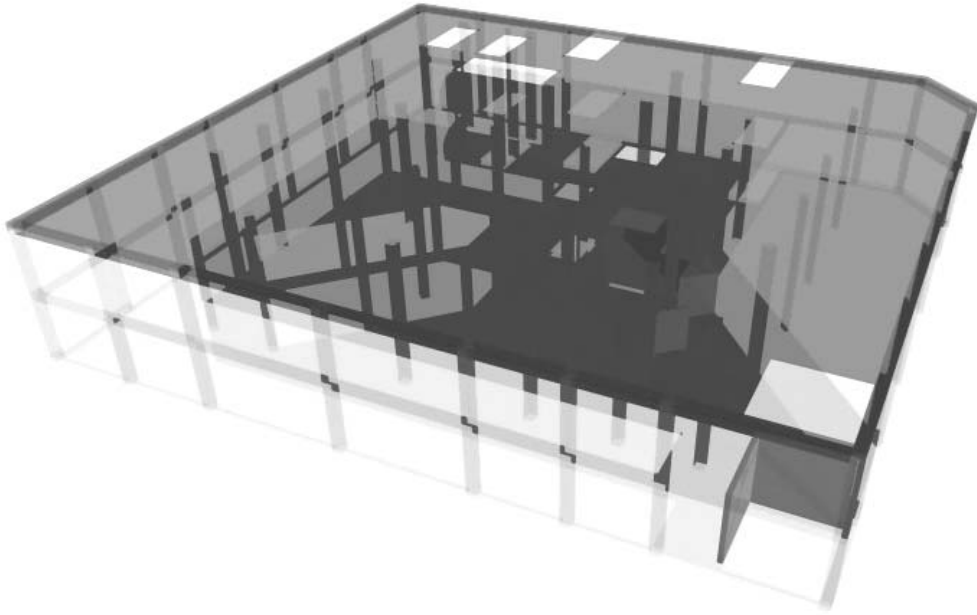

*Day 26*

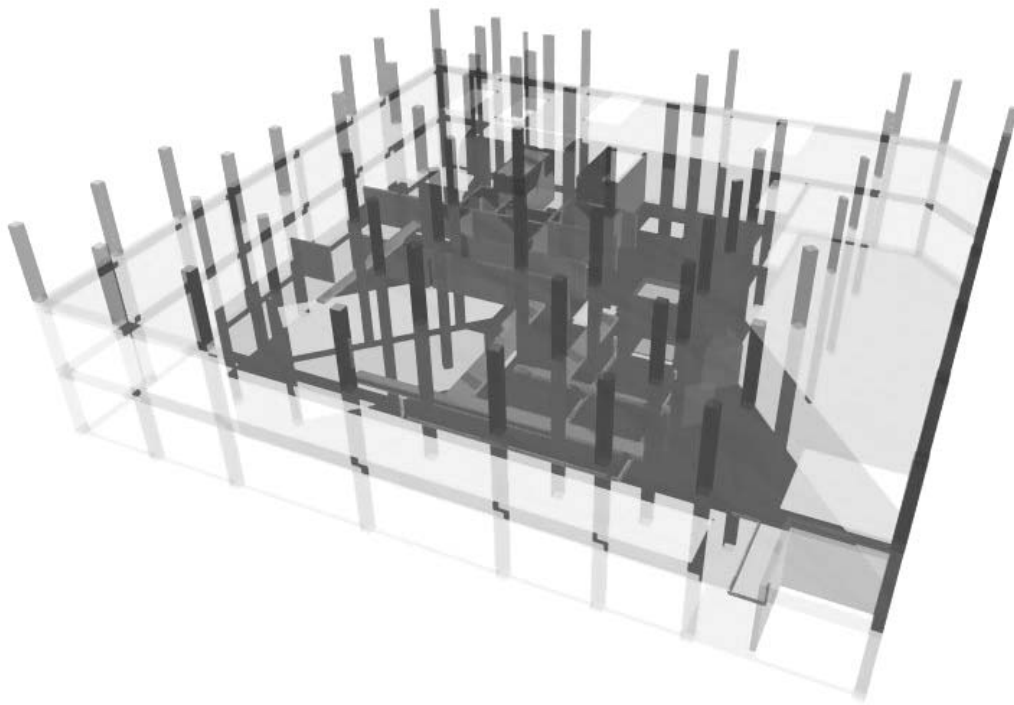

*Day 36*

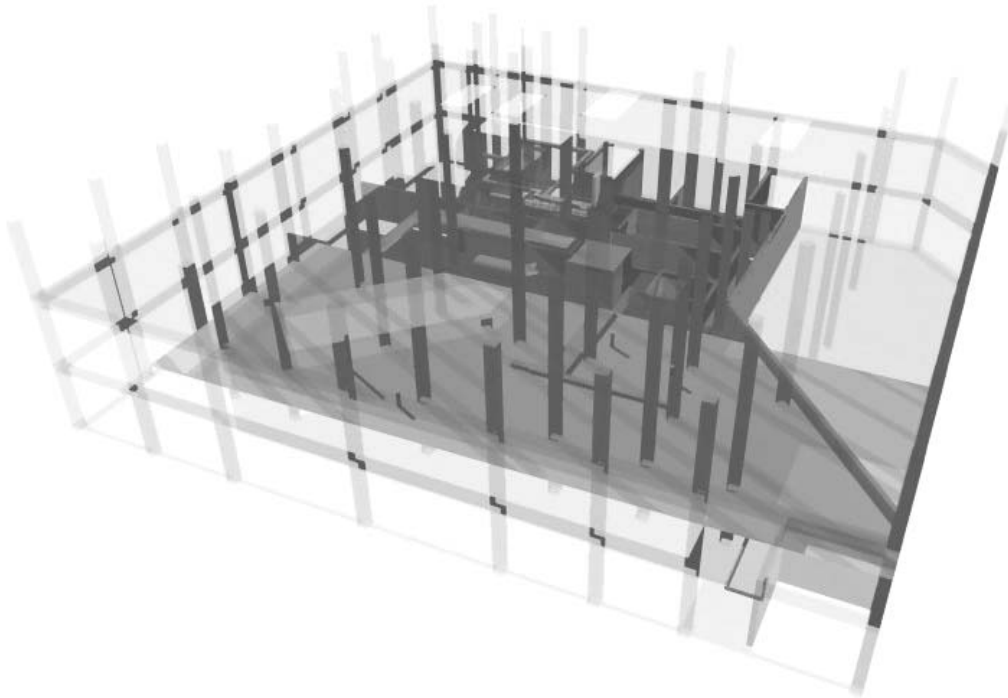

*Day 42*

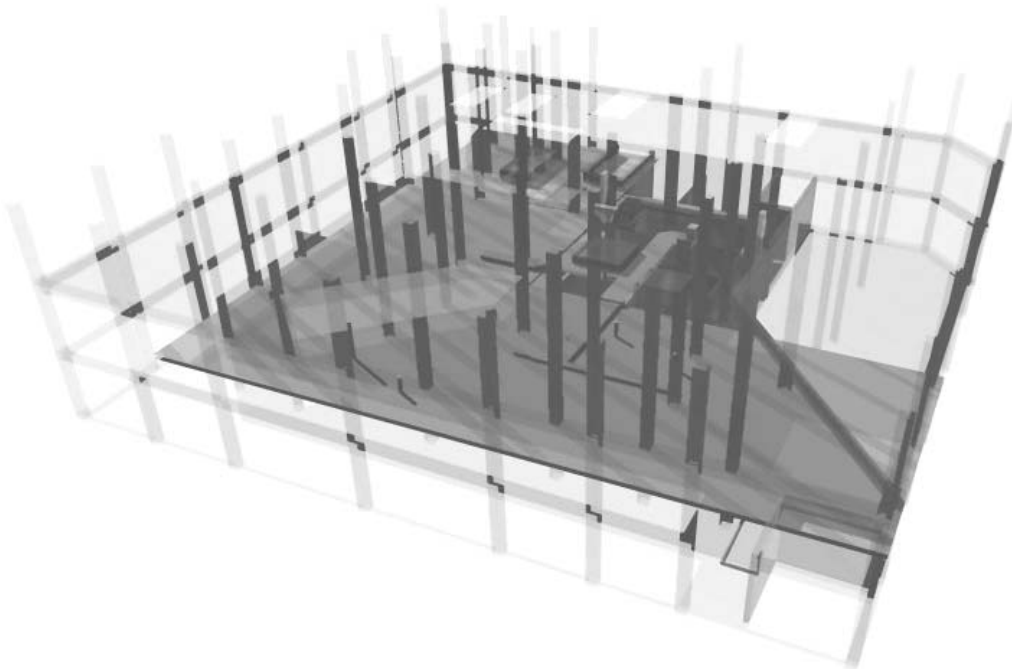

*Day 47*

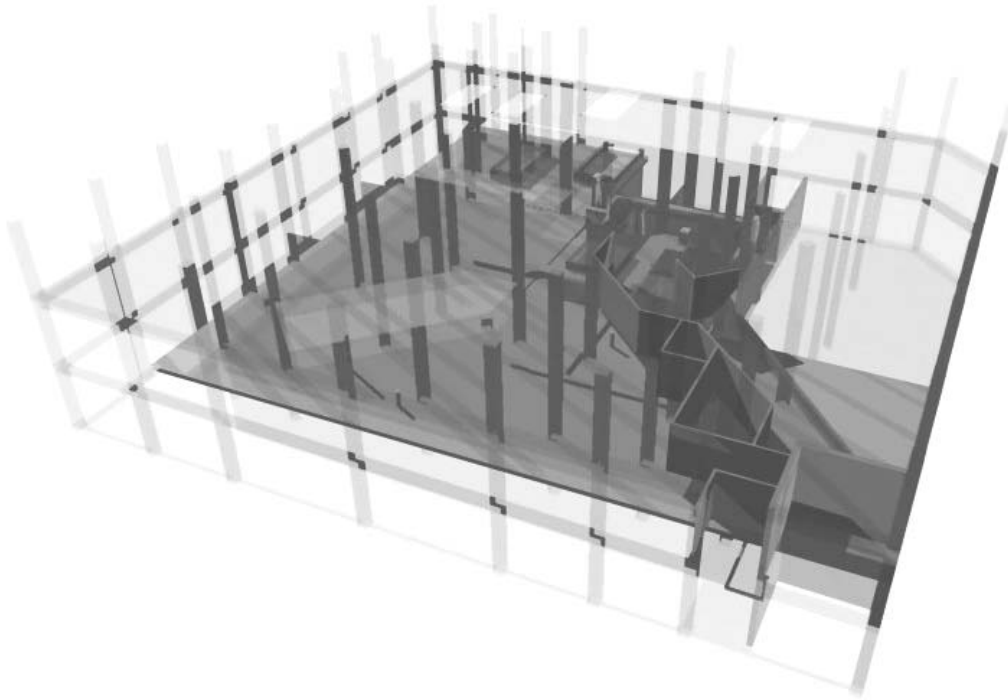

*Day 52*

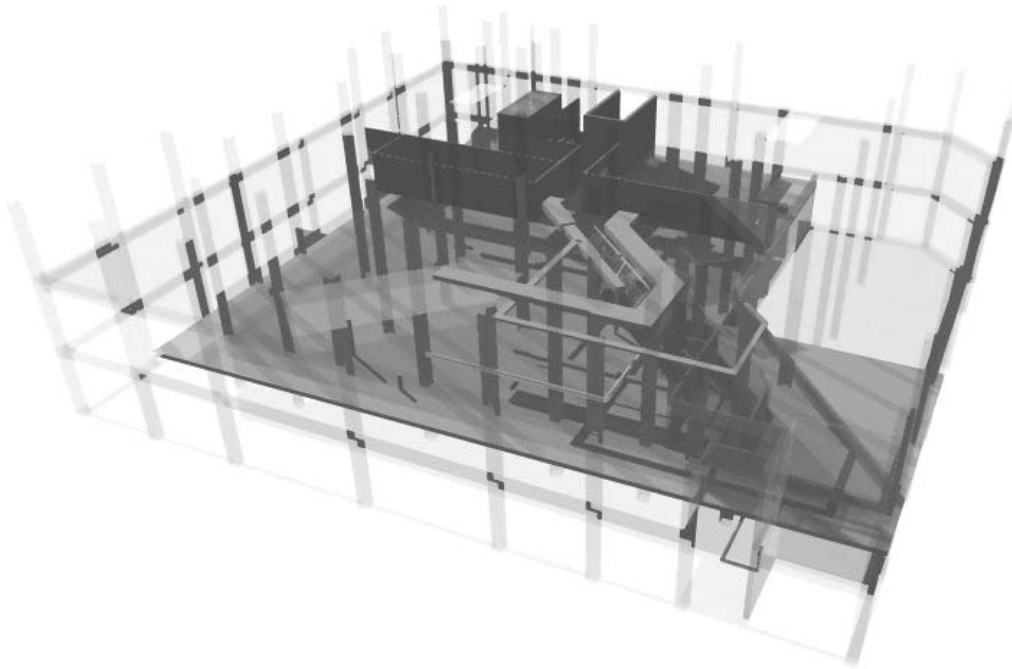

*Day 60*

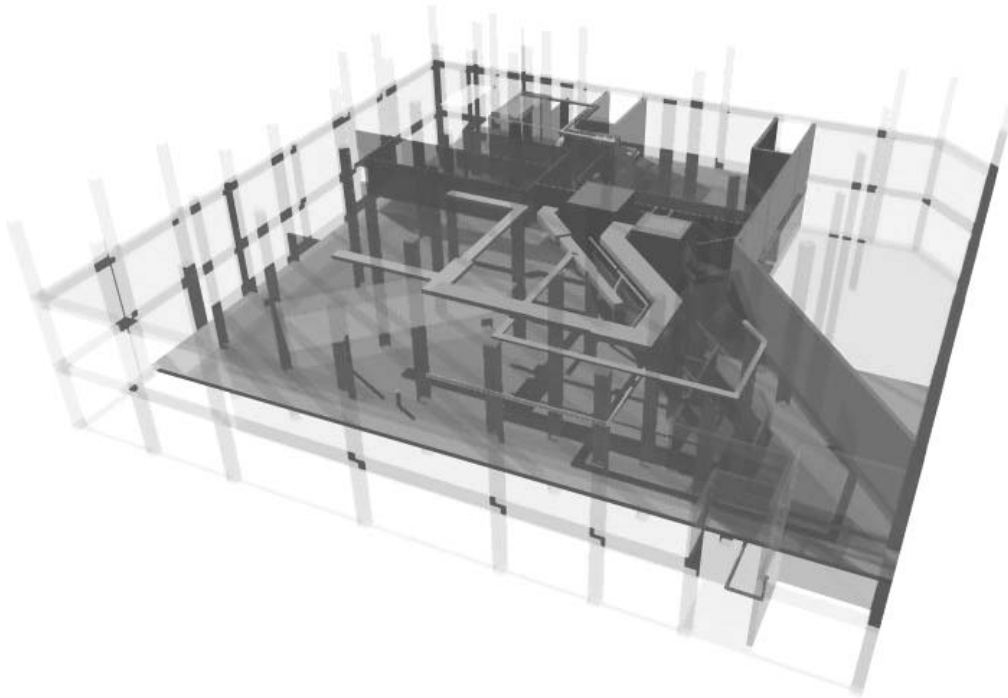

*Day 66*

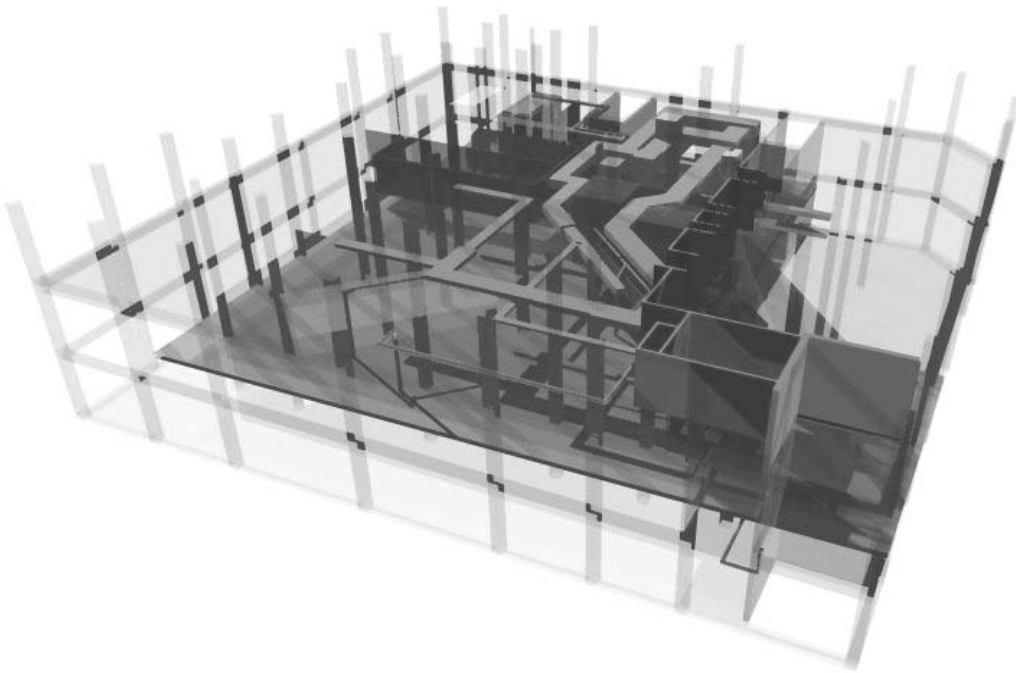

*Day 72*

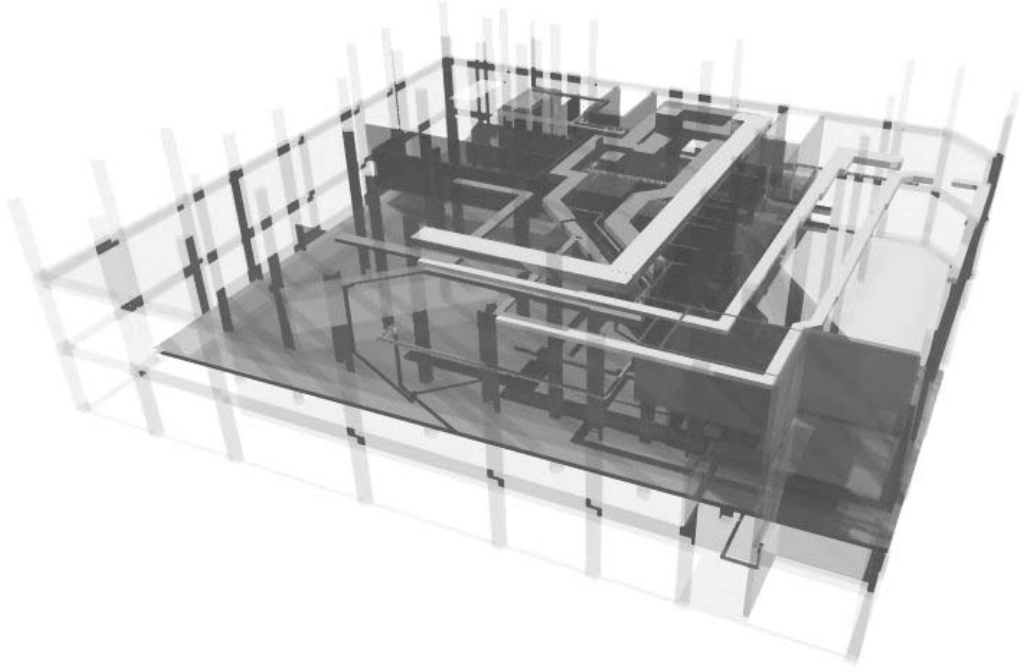

*Day 76*

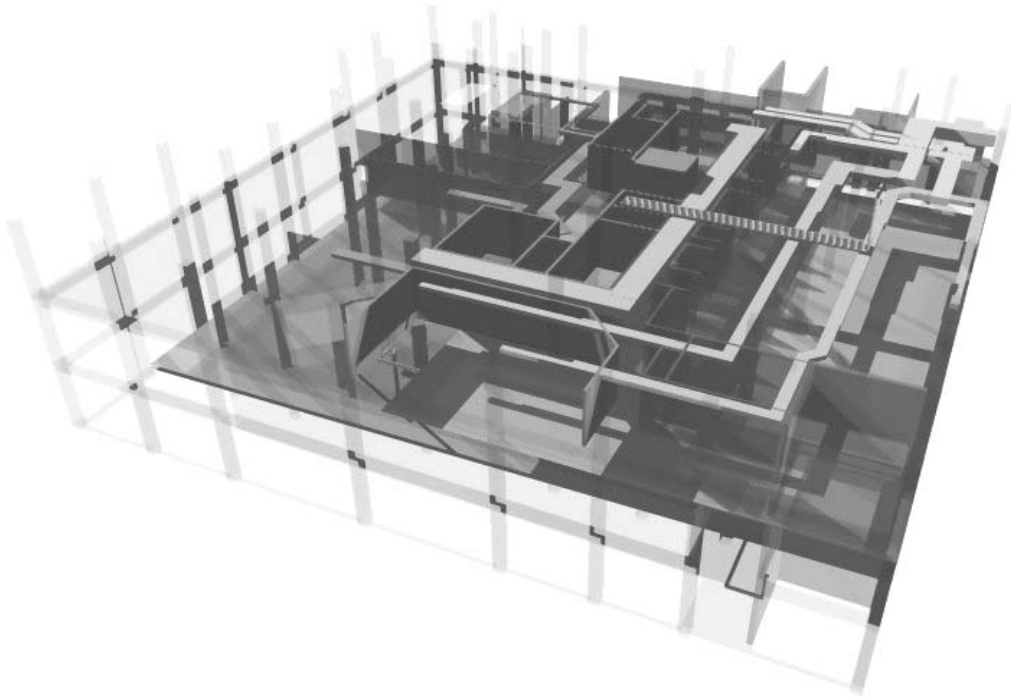

*Day 85*

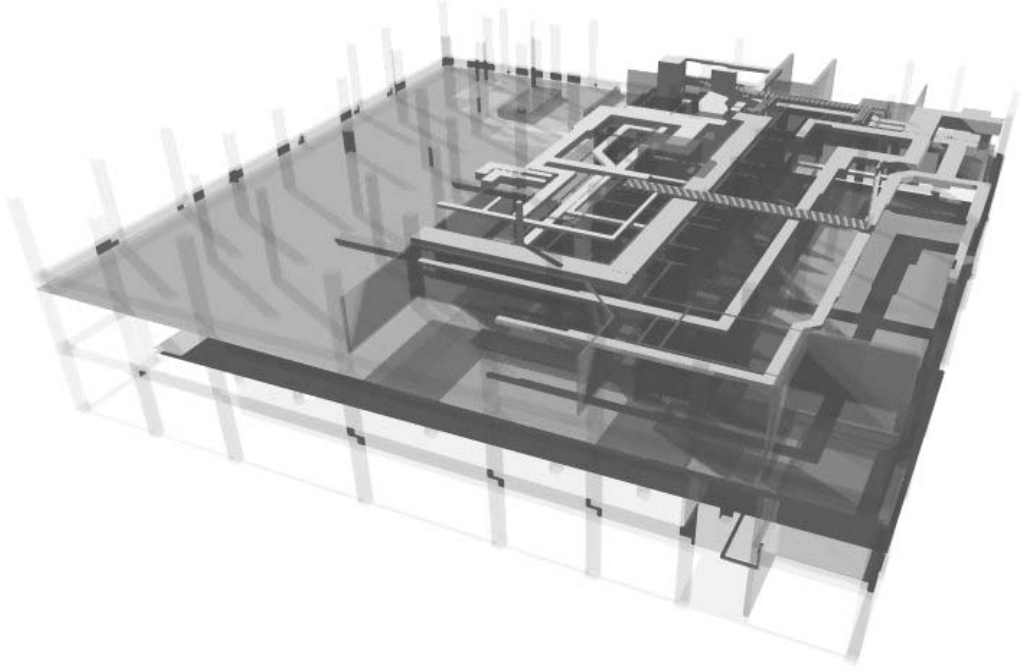

*Day 91*

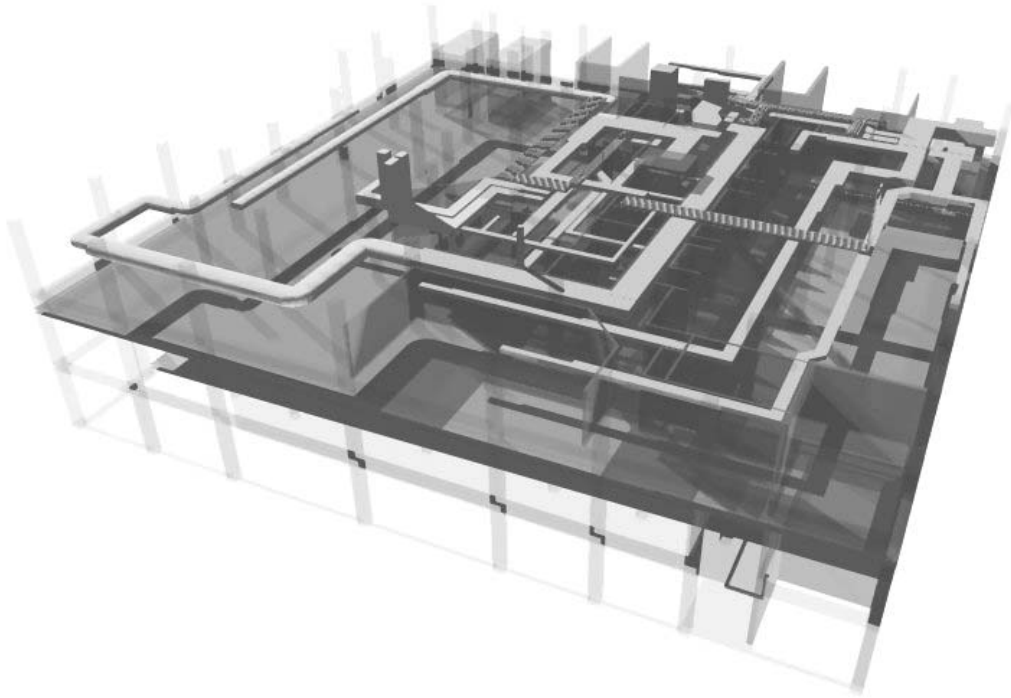

*Day 99*