

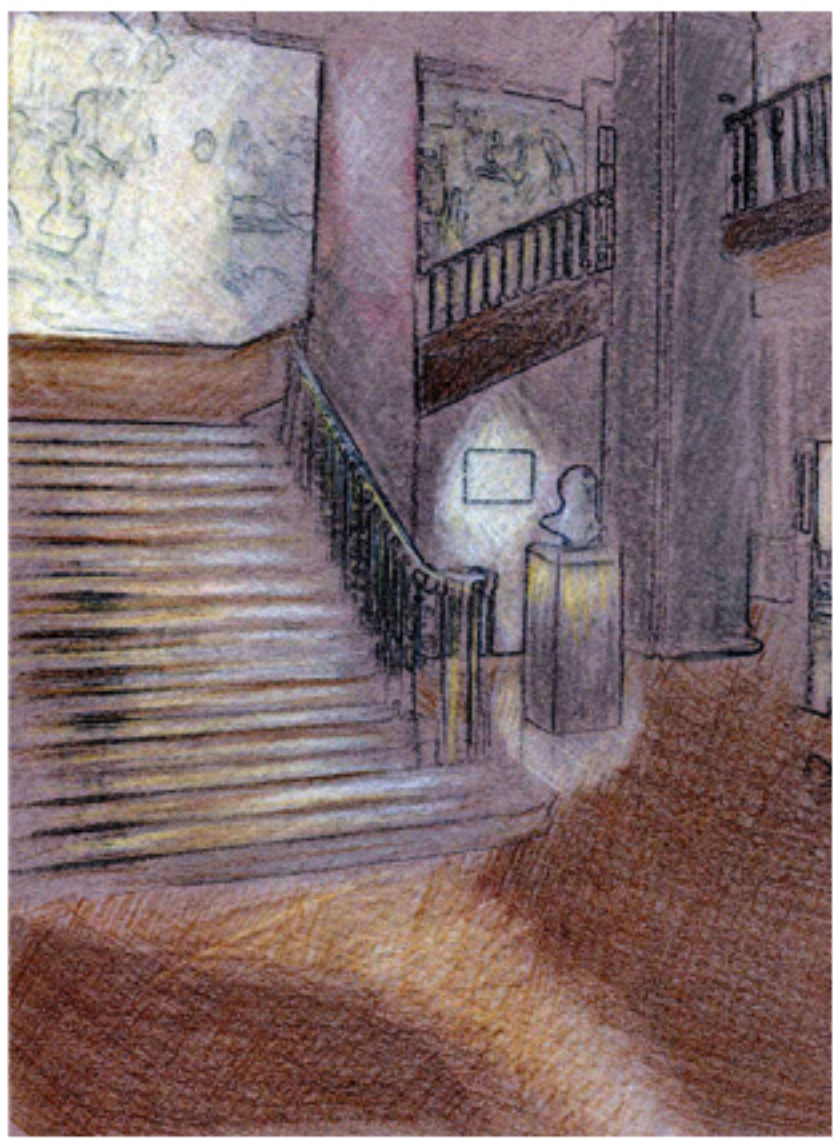

JGC
Jennifer Gabrielle Curley

Portfolio
Architectural Lighting Design





Jennifer Gabbyelle Curley
JGC

Portfolio

Architectural Lighting Design



Coursework: Old Main Lighting Concepts

Inspiration



Design Metaphor: Spring



Pictures from internet

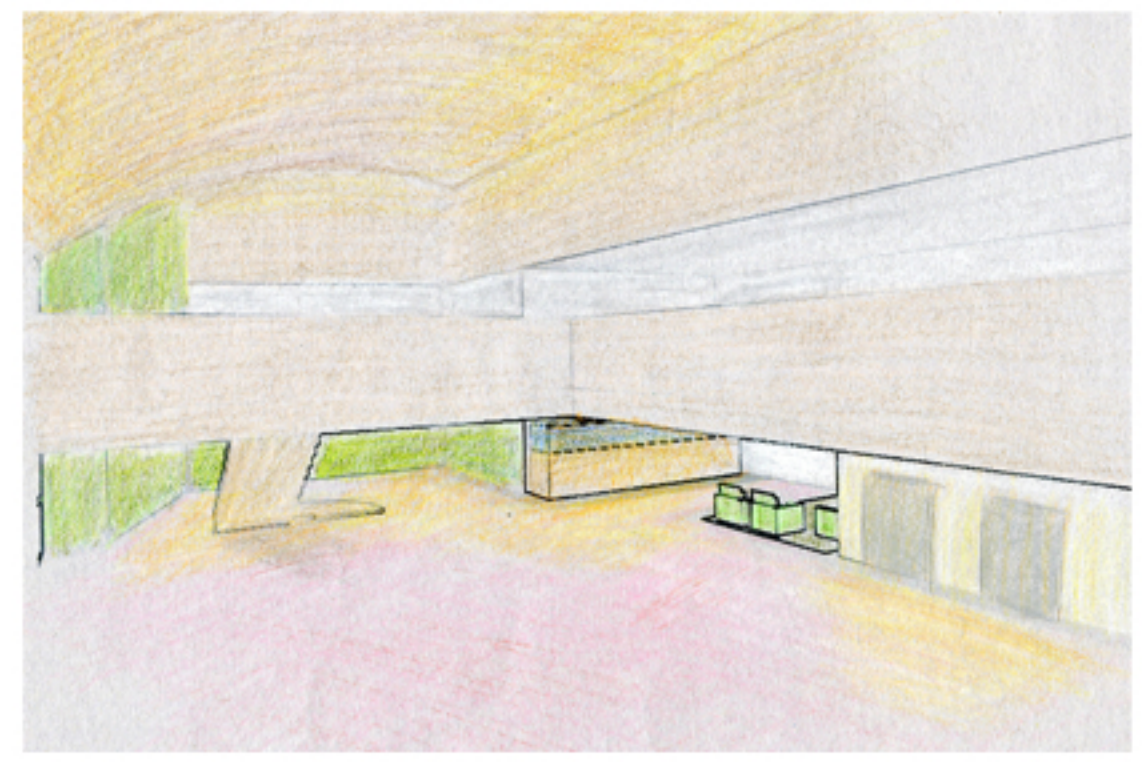

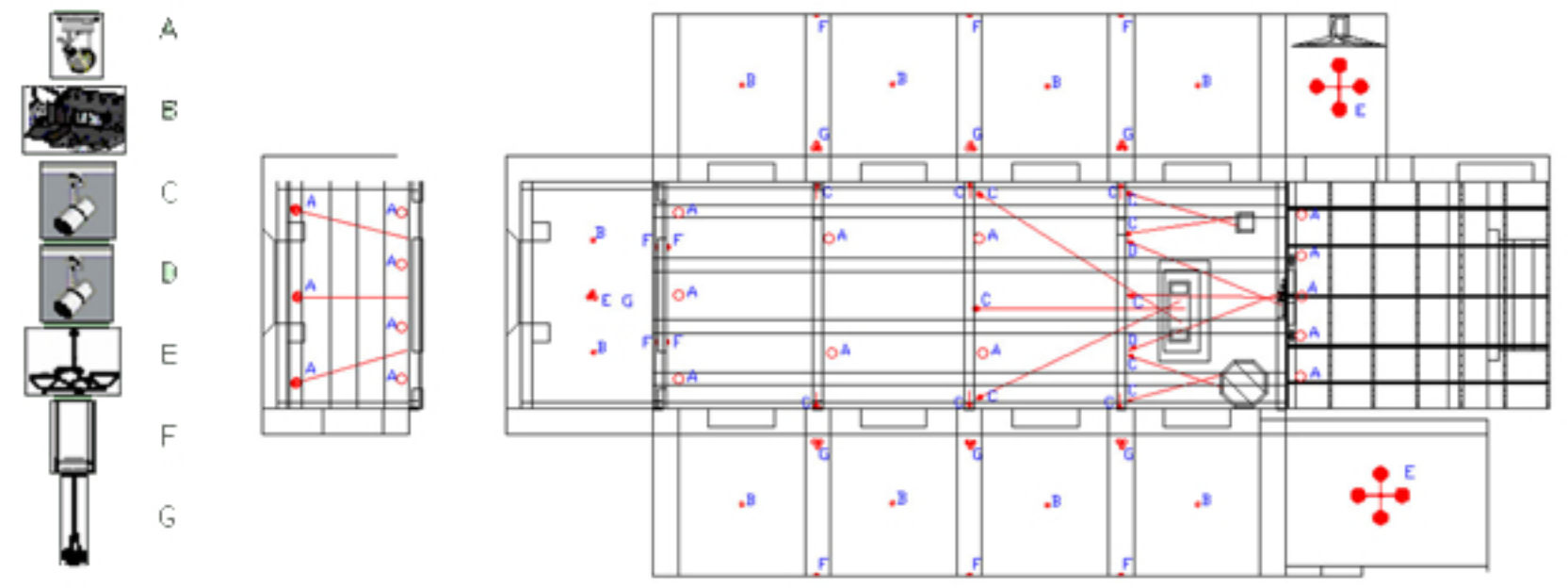
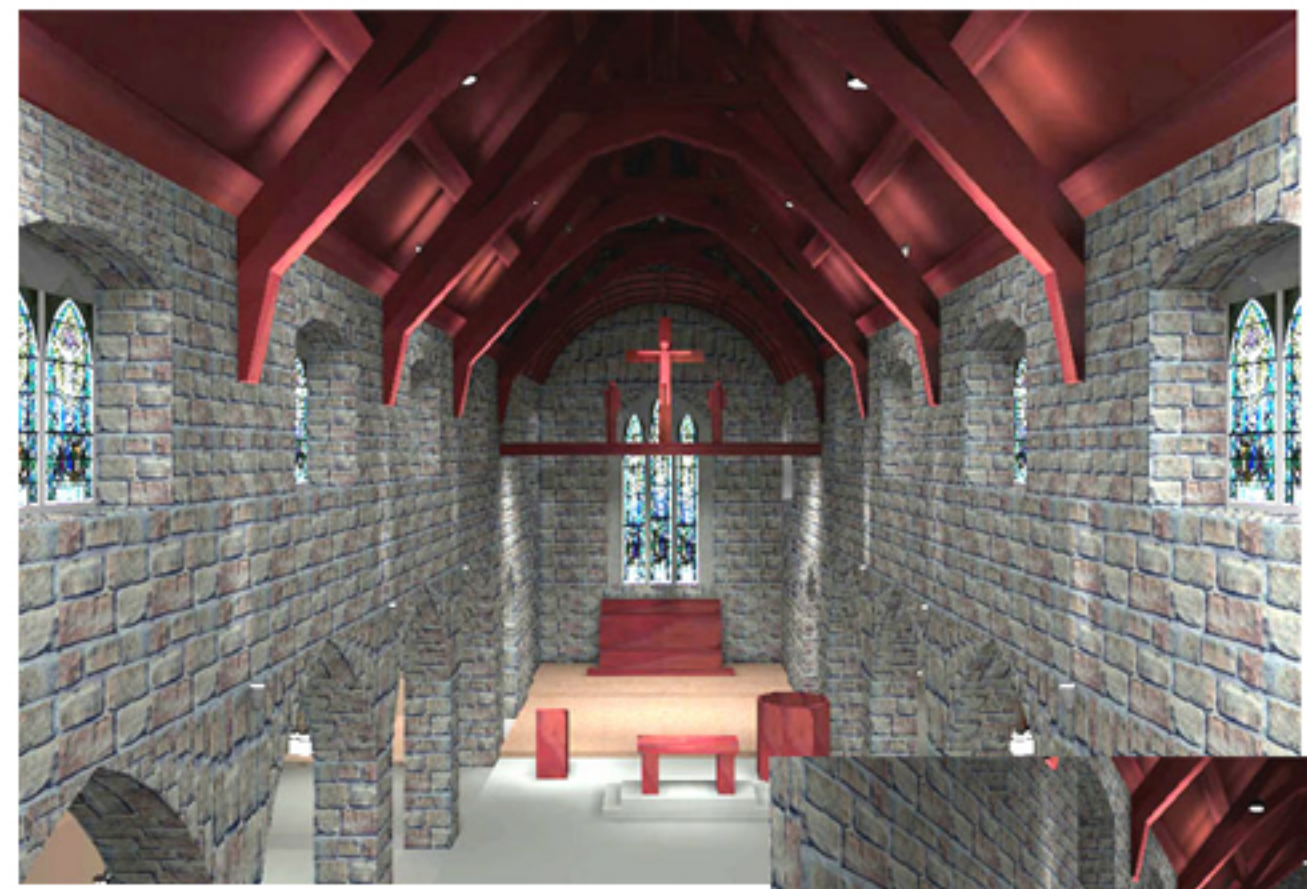

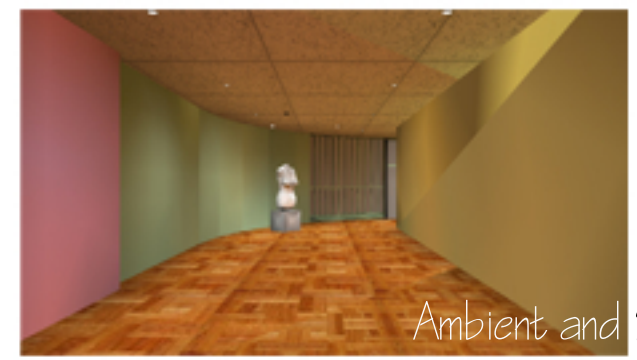
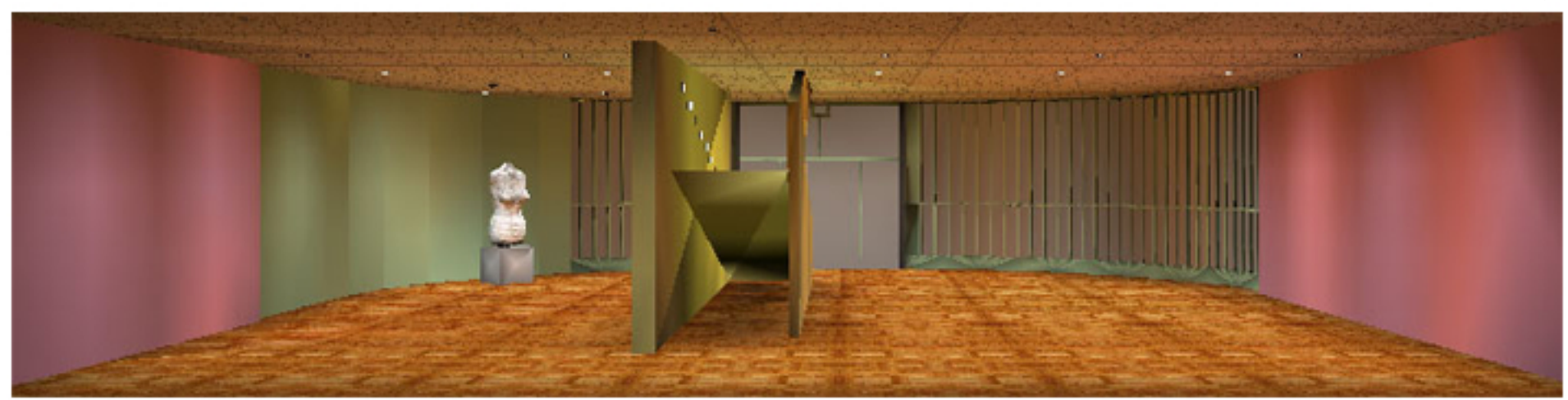
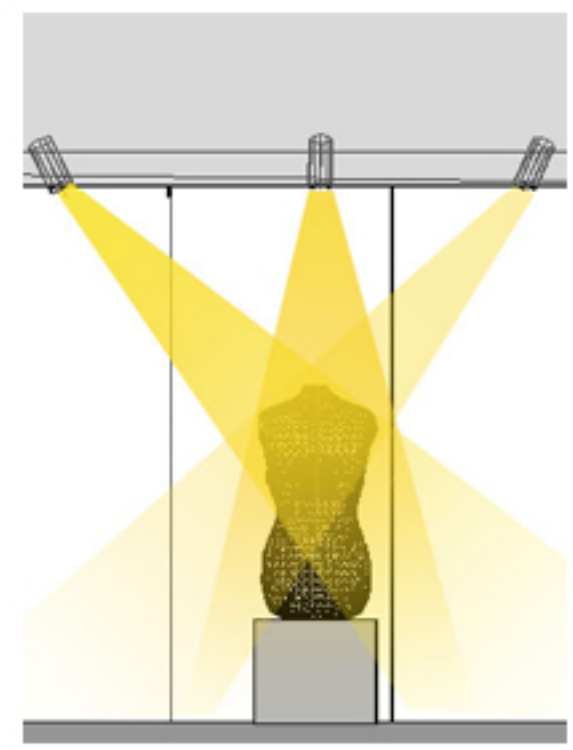

Ambient and Spot Lighting

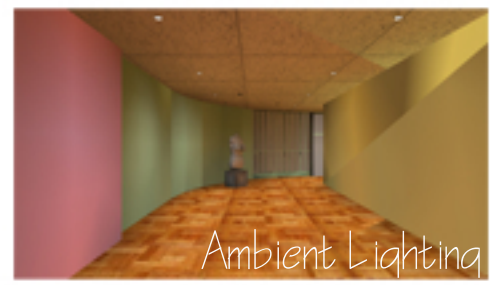
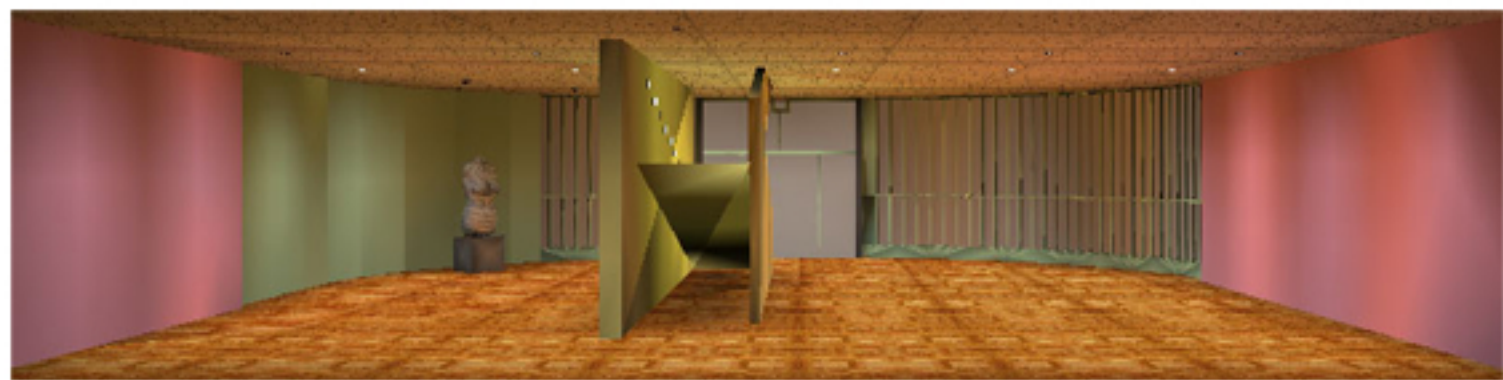

Ambient Lighting



Spot Lighting

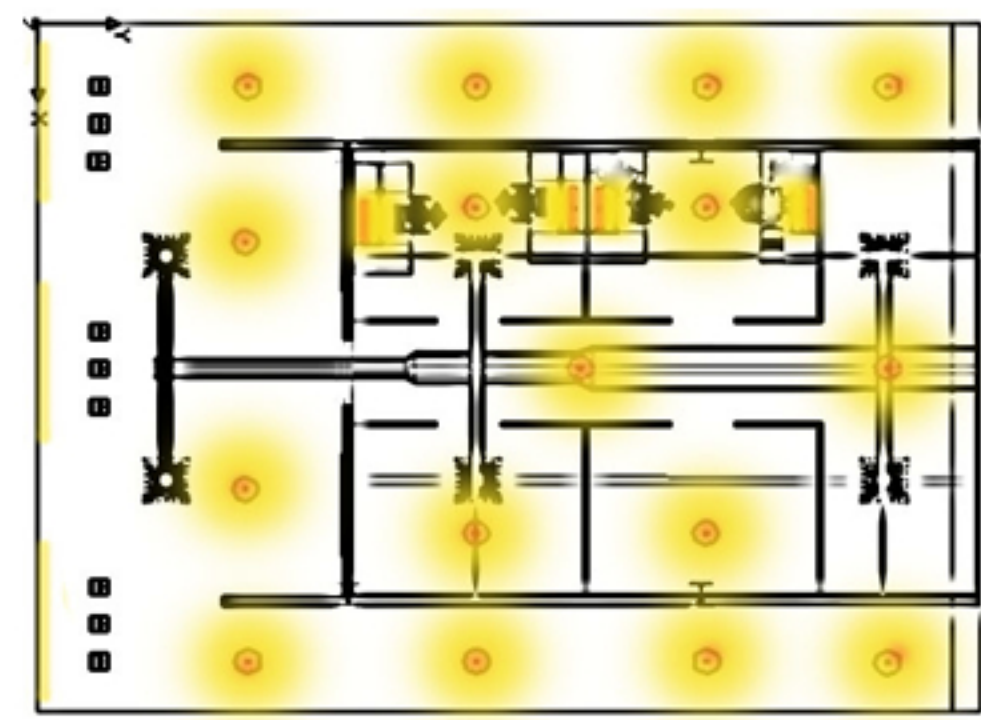

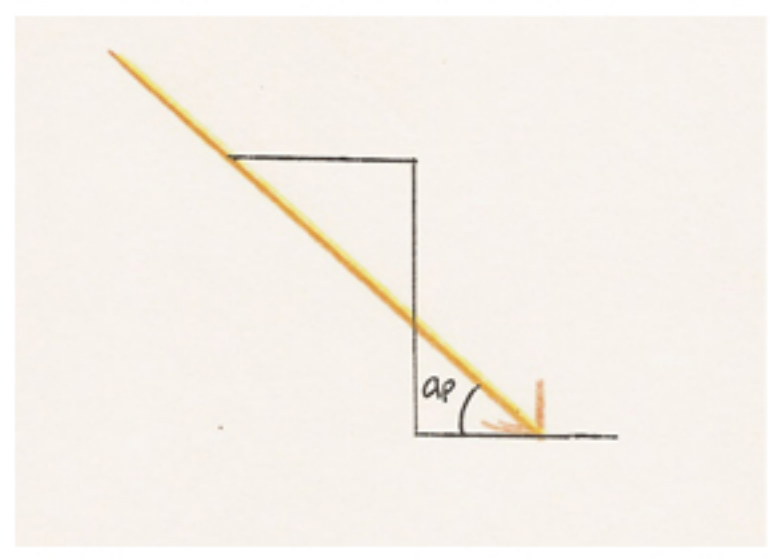
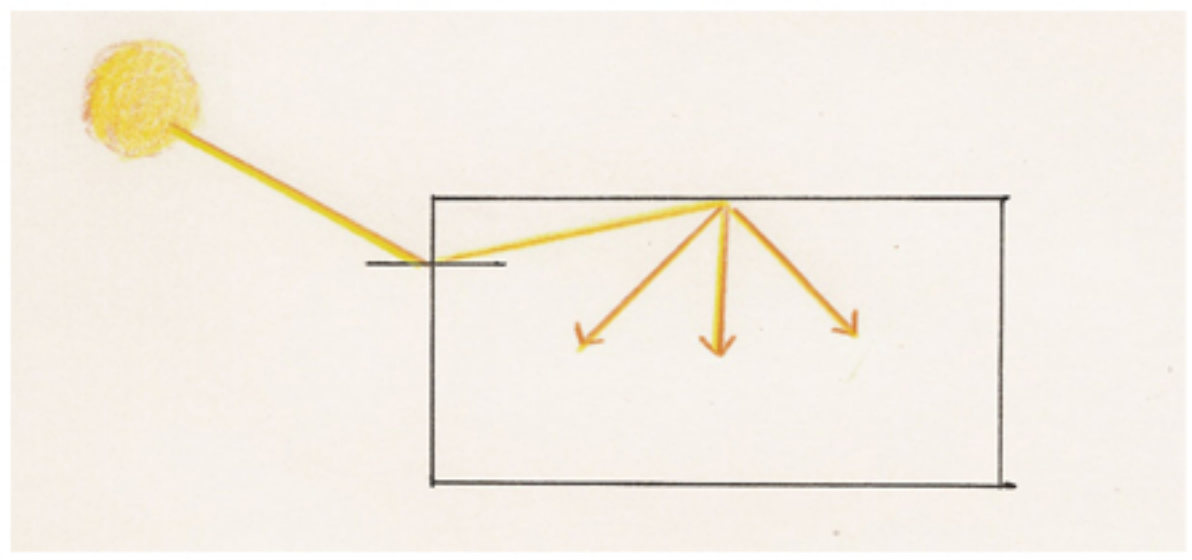
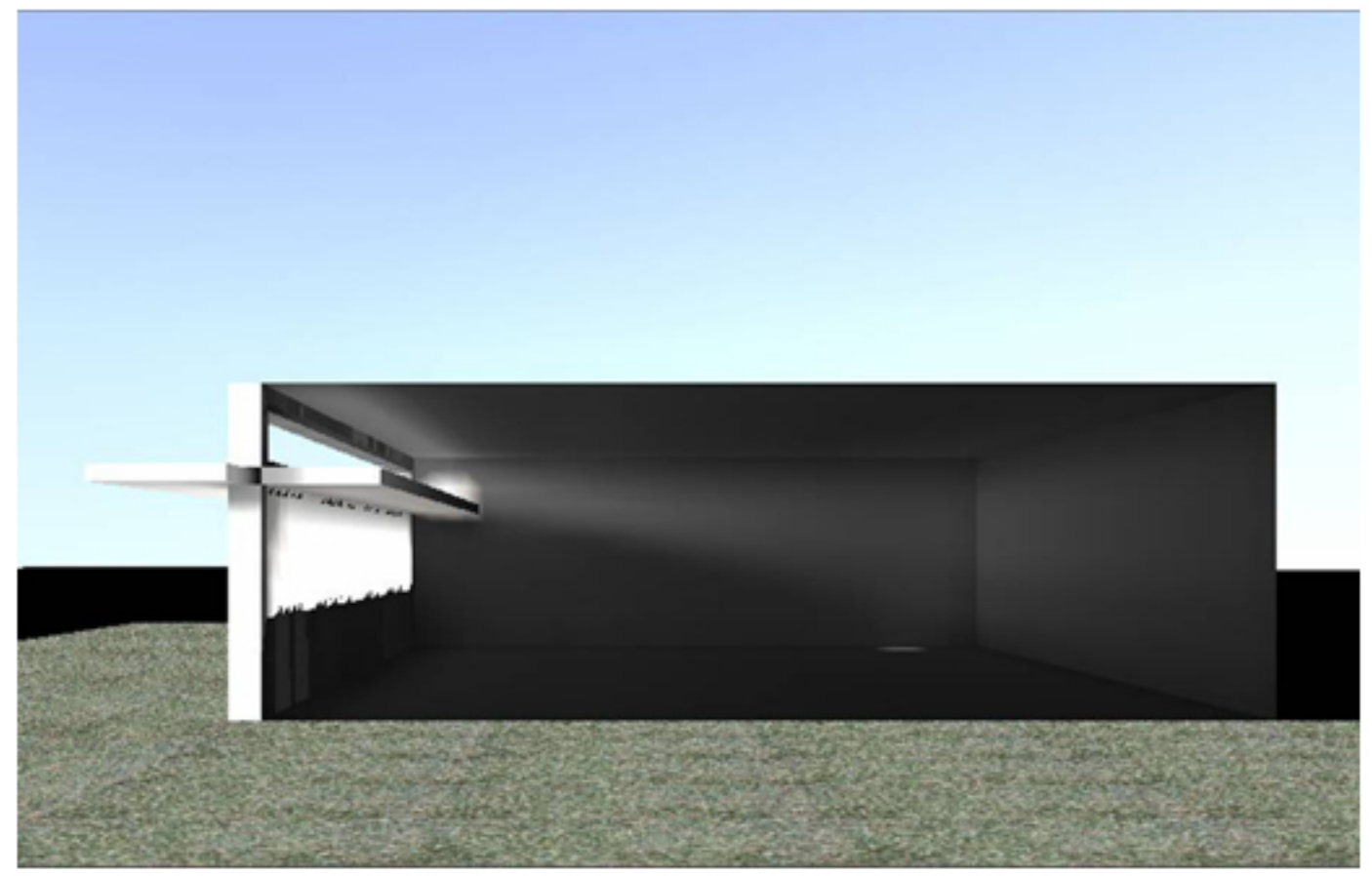
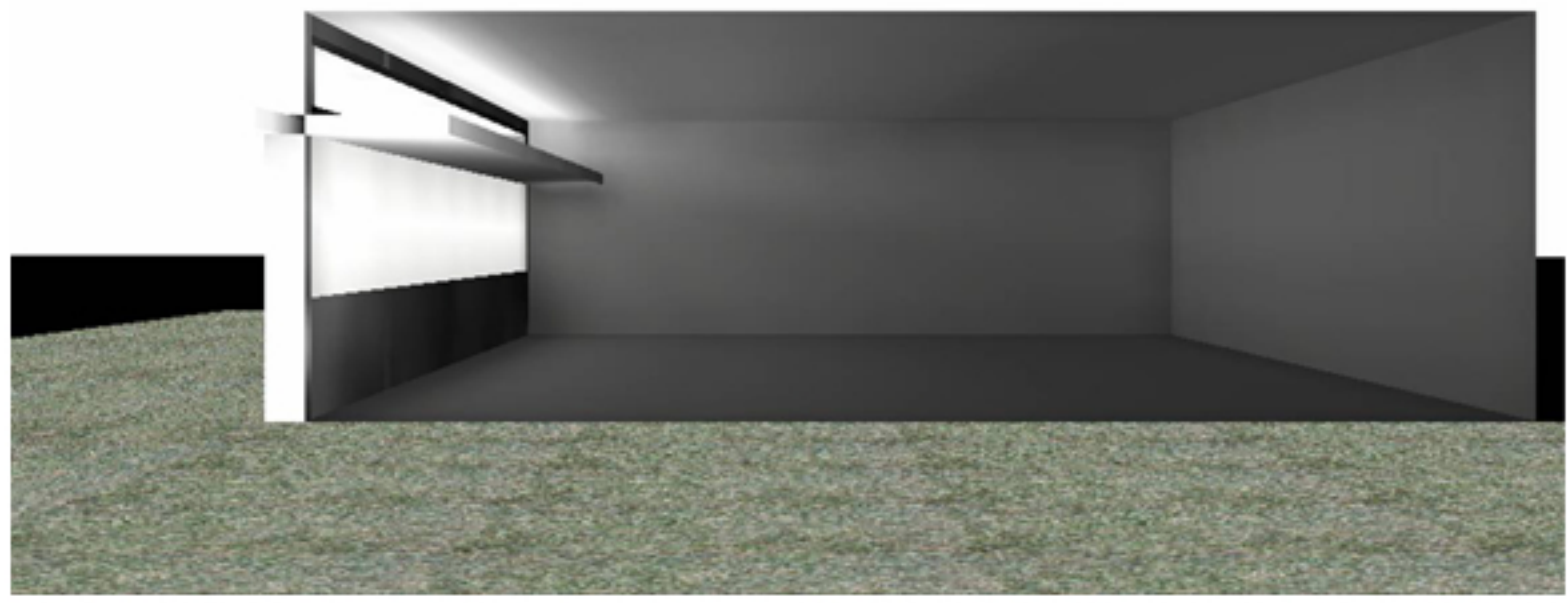

Existing Lighting Analysis

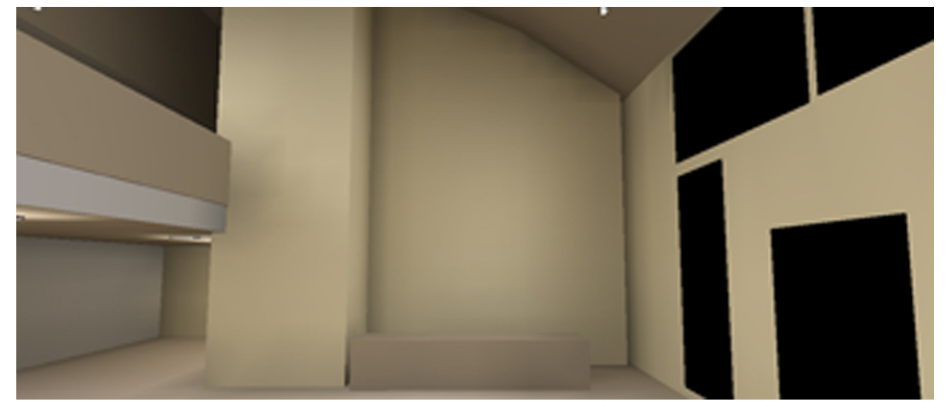
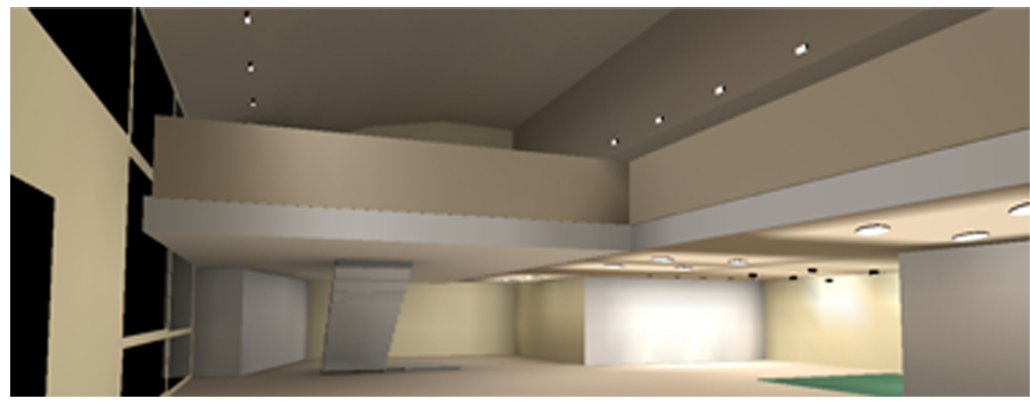

Daylight Analysis



March

June

December

	March 21 at 10am			Vertical Illumination (FC) (FC)	March 21 at 1pm			Vertical Illumination (FC) (FC)
	Lobby Illuminance (FC) at floor	Visitor Lounge Illuminance (FC) at 2.5'	Reception Illuminance (FC) at 2.5'		Lobby Illuminance (FC) at floor	Visitor Lounge Illuminance (FC) at 2.5'	Reception Illuminance (FC) at 2.5'	
Average	483.81	17.66	895.78	363	201.69	6.51	523.48	120.5
Maximum	1461	80.9	1381	167	2634	18.7	2320	310
Minimum	8.6	8.1	205	1.47	0.2	3.3	113	40.2
Avg/Min	56.26	2.8	4.36	2.17	1008	1.97	4.61	3
Max/Min	169.92	7.53	6.72	0	13174	5.67	20.43	7.73

	June 21 at 10am			Vertical Illumination (FC) in lobby	June 21 at 1pm			Vertical Illumination (FC) in lobby
	Lobby Illuminance (FC) at floor	Visitor Lounge Illuminance (FC) at 2.5'	Reception Illuminance (FC) at 2.5'		Lobby Illuminance (FC) at floor	Visitor Lounge Illuminance (FC) at 2.5'	Reception Illuminance (FC) at 2.5'	
Average	541.17	19.38	163.25	326.72	229.59	6.53	132.8	106.11
Maximum	2627	62.6	173	504	3125	19.4	183	230
Minimum	1.4	8.6	147	210	0.2	3.2	87.6	39.7
Avg/Min	457.98	2.25	1.11	1.55	1147	2.04	1.52	2.67
Max/Min	1876	7.28	1.17	2.39	15629	6.06	2.1	5.8

	December 21 at 10am			Vertical Illumination (FC) in lobby	December 21 at 1pm			Vertical Illumination (FC) in lobby
	Lobby Illuminance (FC) at floor	Visitor Lounge Illuminance (FC) at 2.5'	Reception Illuminance (FC) at 2.5'		Lobby Illuminance (FC) at floor	Visitor Lounge Illuminance (FC) at 2.5'	Reception Illuminance (FC) at 2.5'	
Average	381.07	10.28	1002	243.17	55.22	3.9	87.65	48.58
Maximum	1824	30.7	1734	235	335	11.8	130	103
Minimum	2.2	5	363	166	0.1	1.7	53.6	19.6
Avg/Min	173.21	2.06	2.76	1.46	552.2	2.29	1.64	2.48
Max/Min	829.32	6.14	4.77	1.77	3352	6.94	2.43	5.29

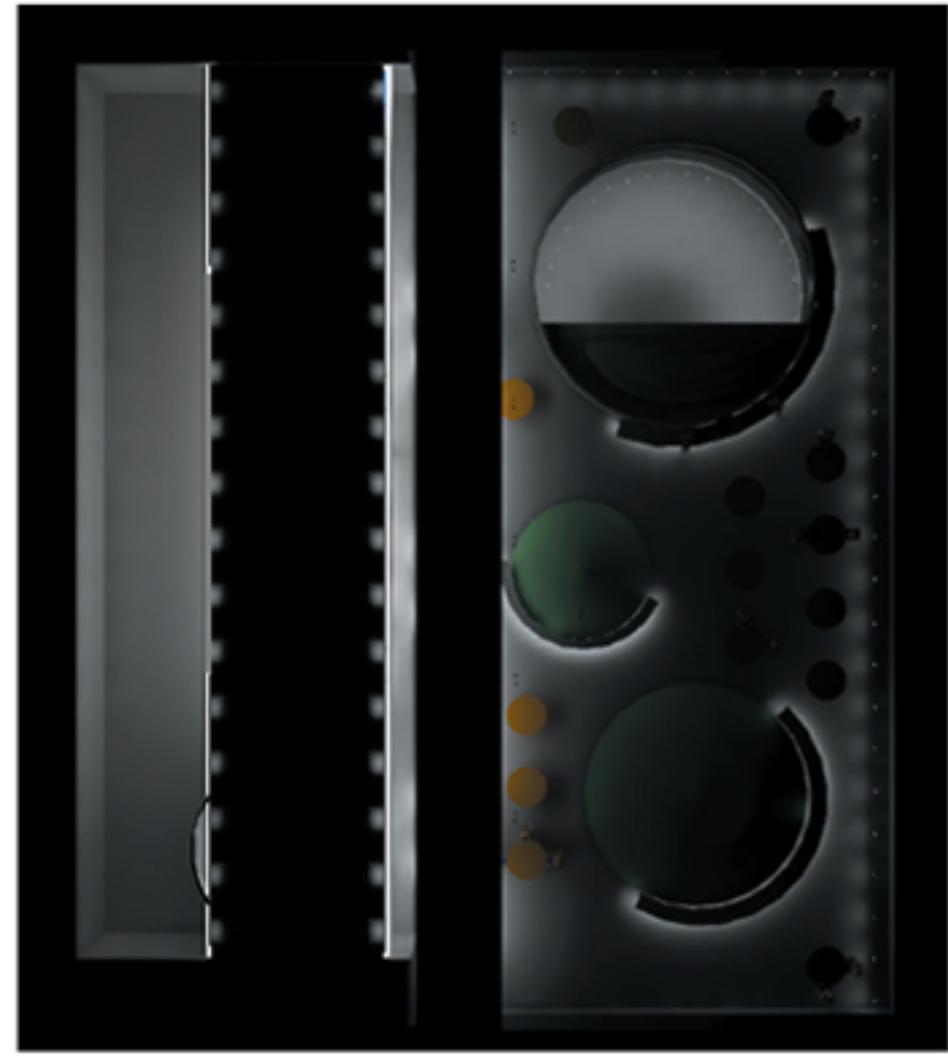
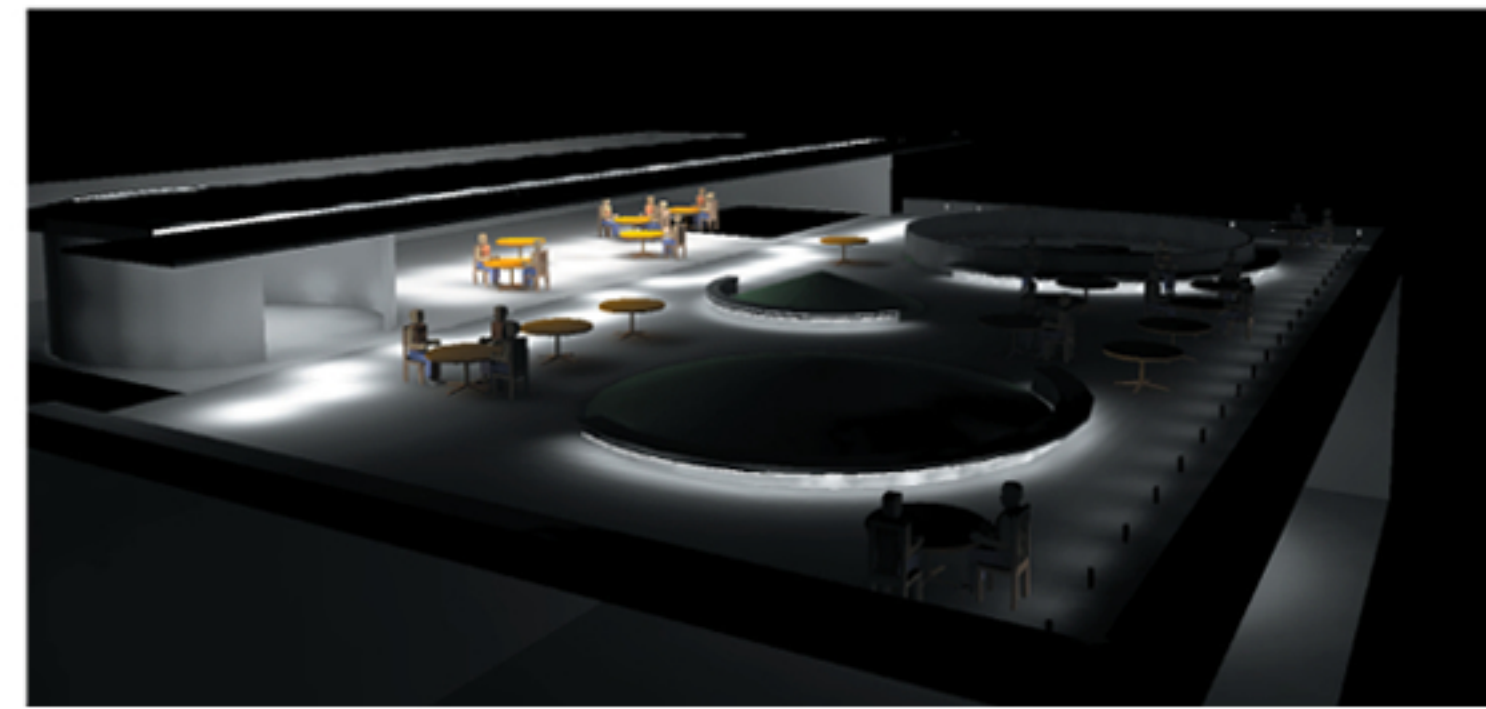

Basic

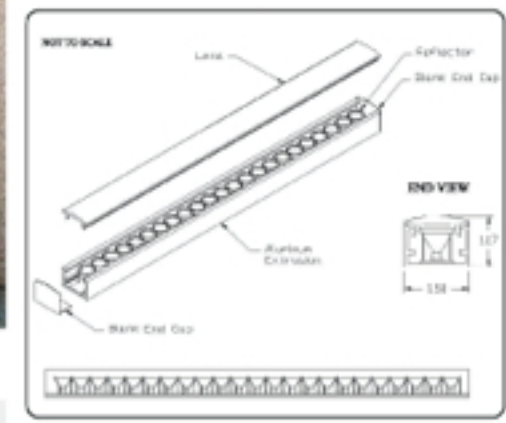
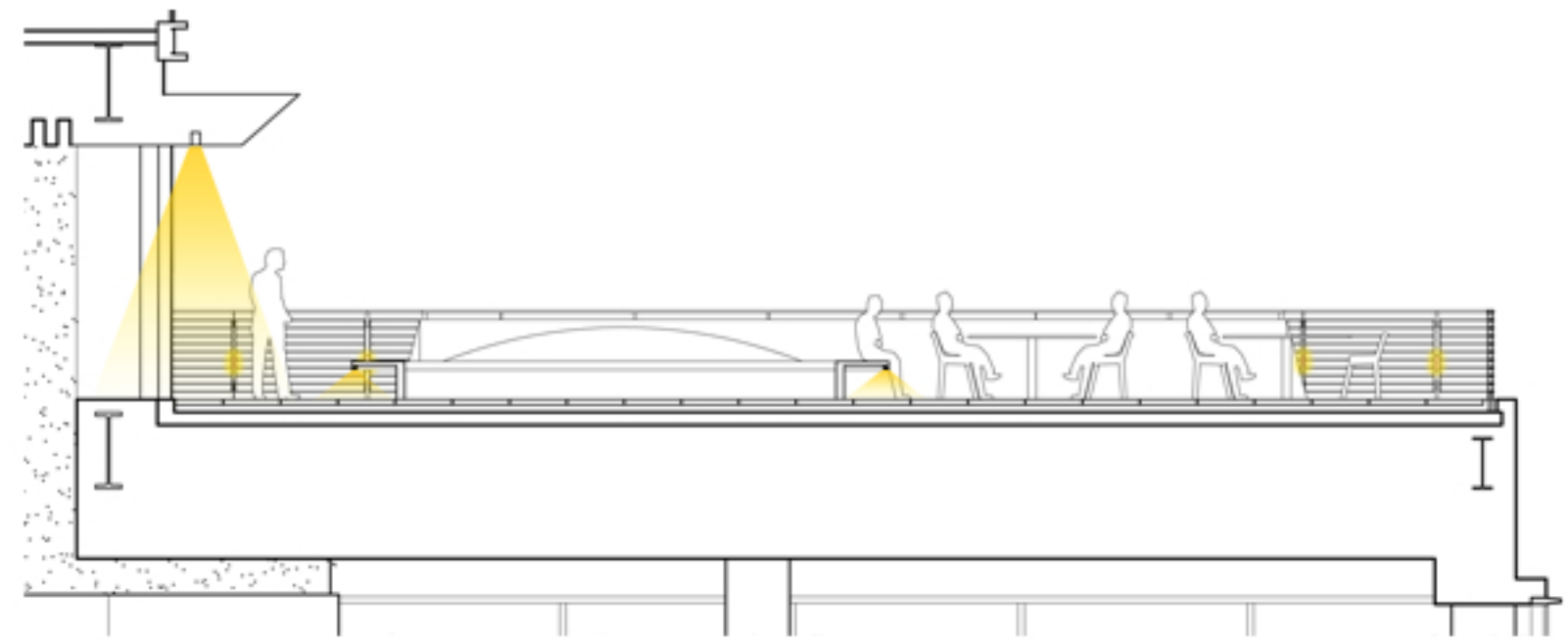
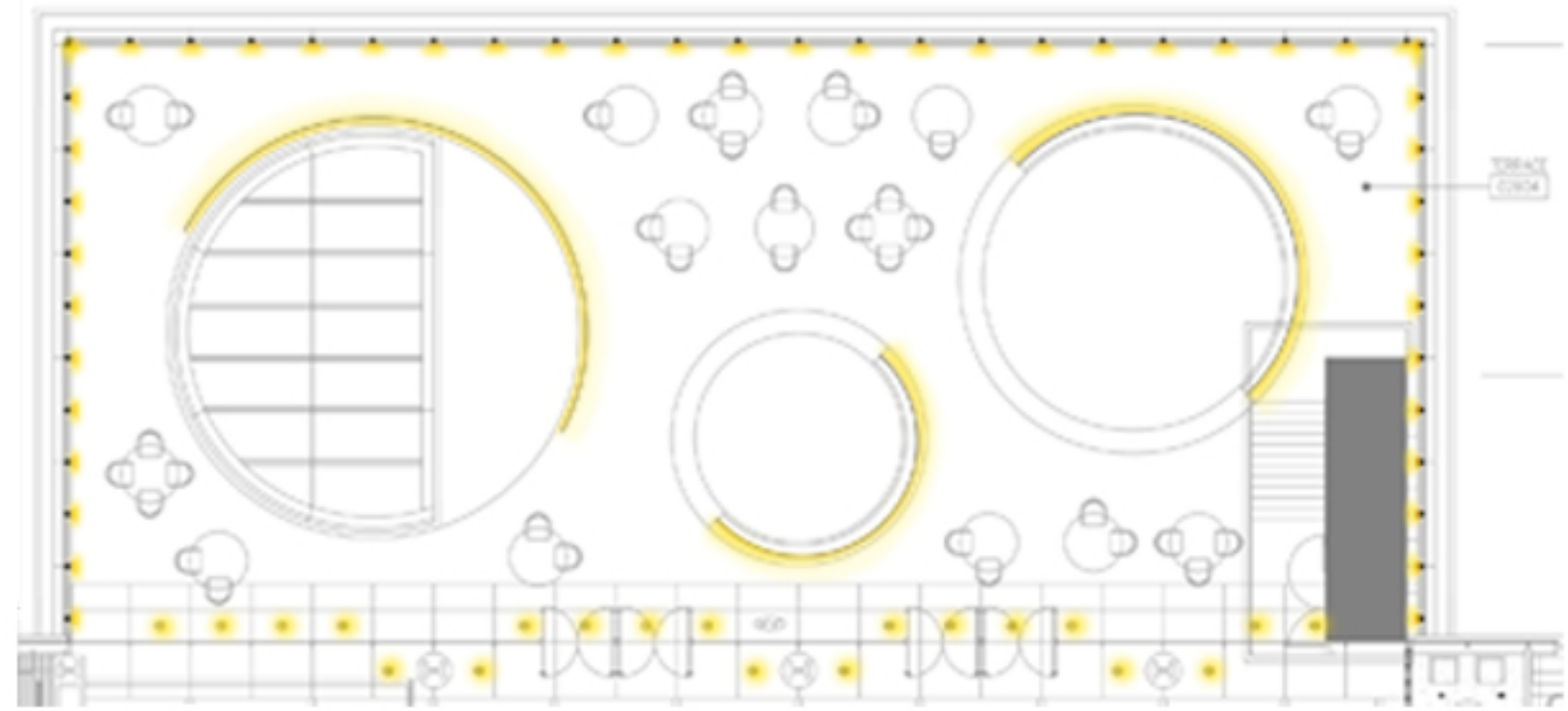

Basic

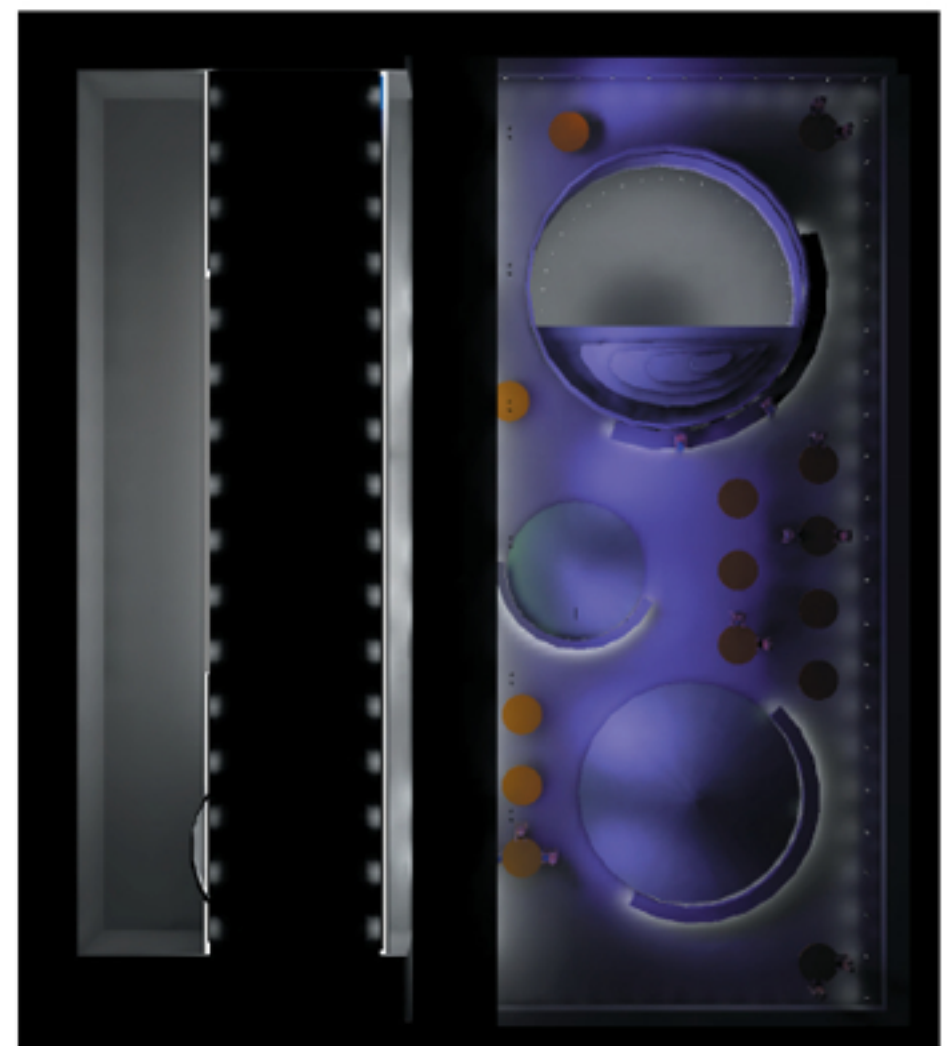
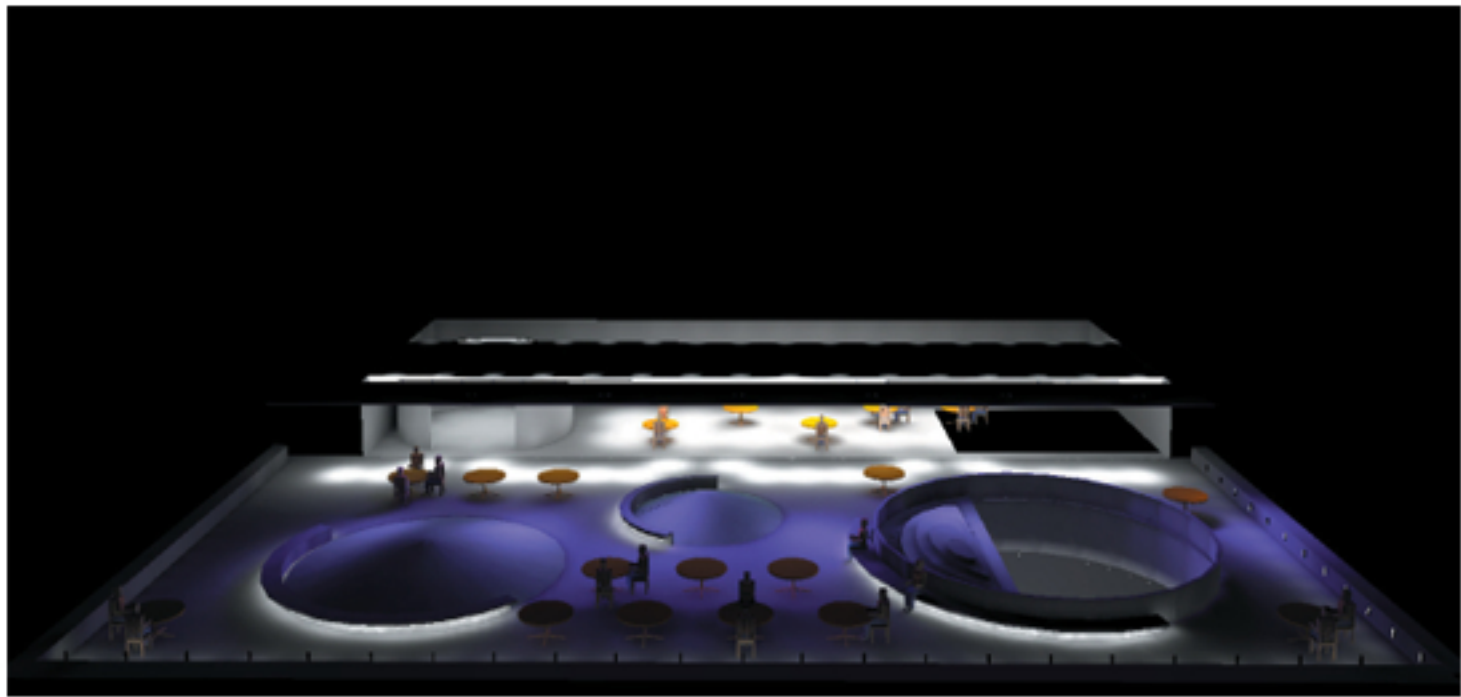

Theatrical Fixture Option

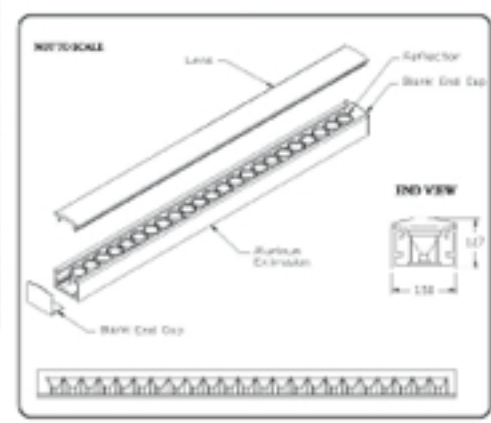
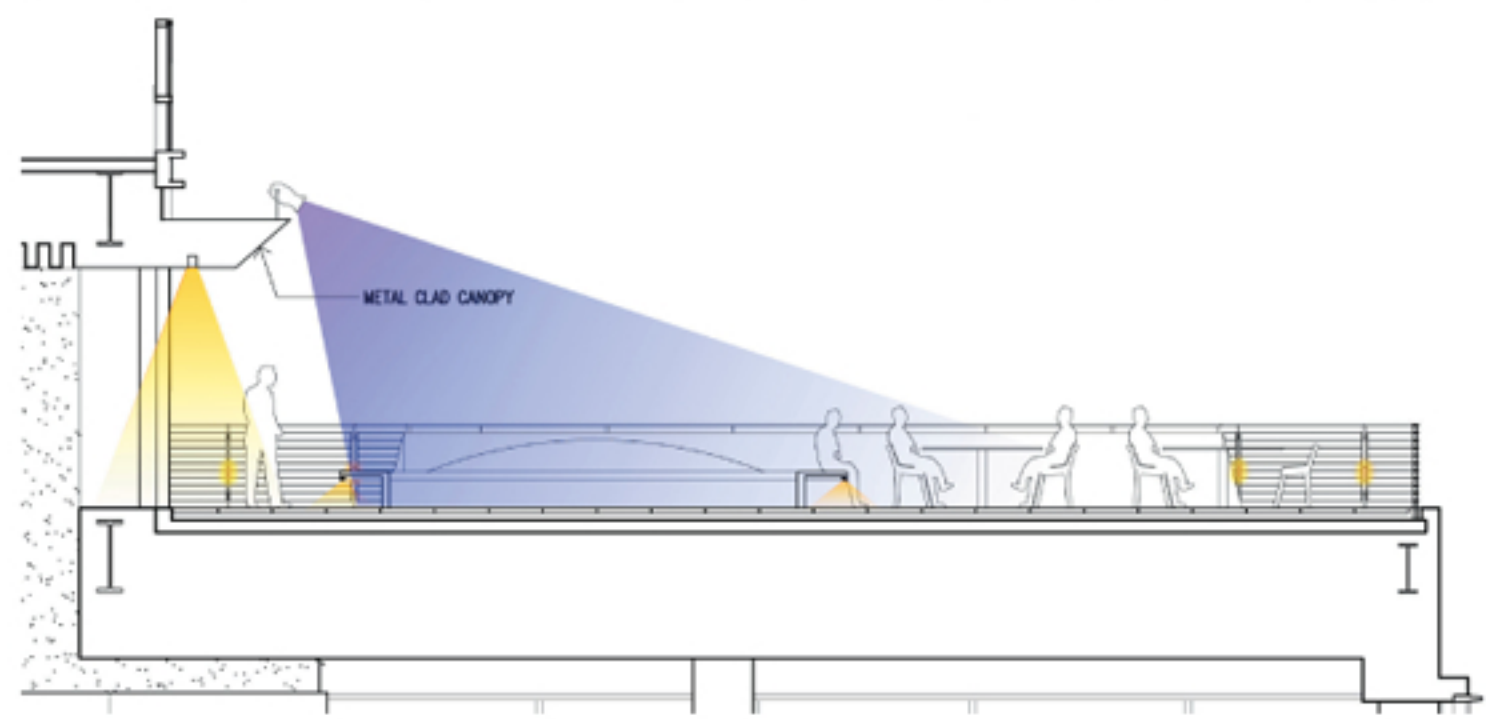
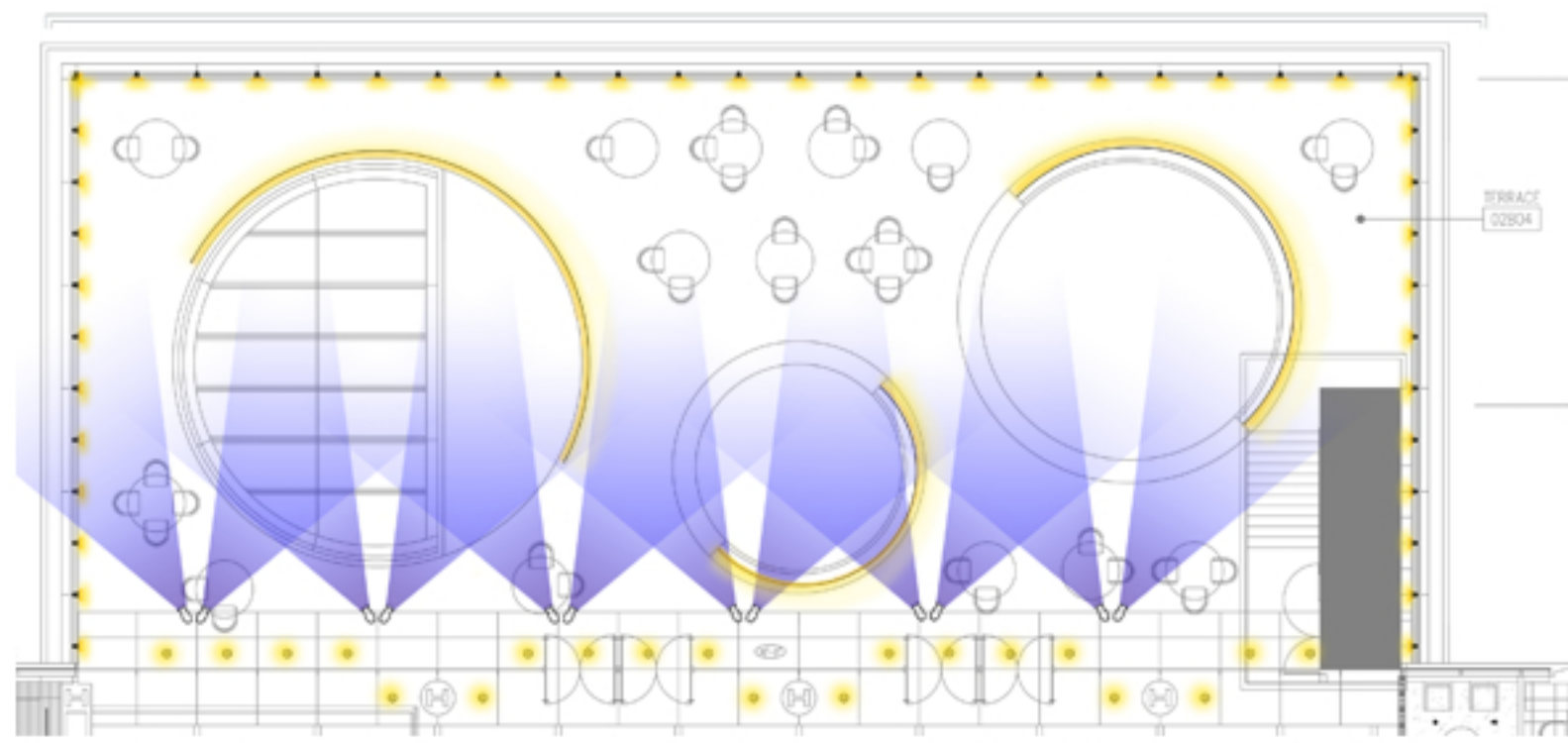

Theatrical Fixture Option

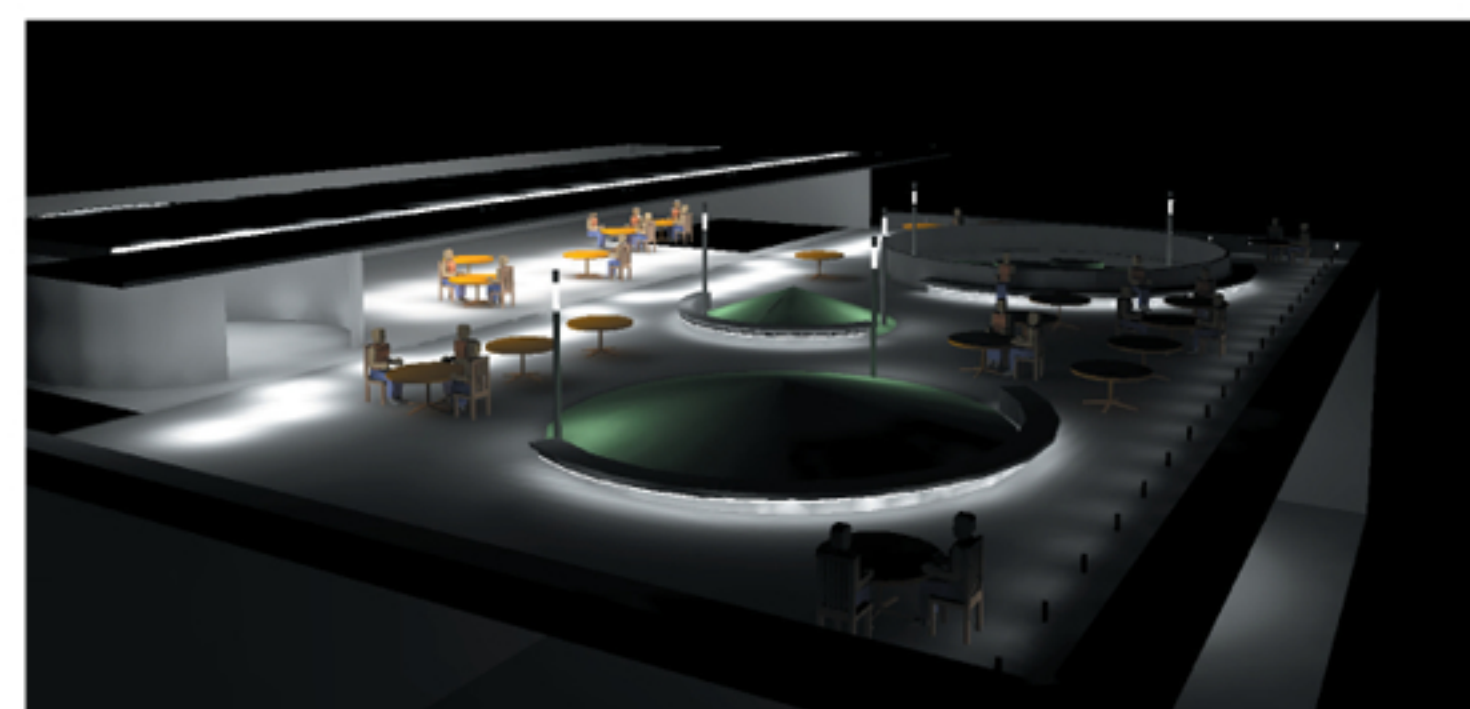

Pole Fixture Option

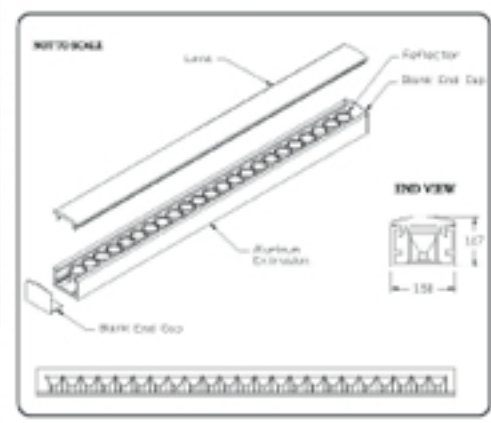
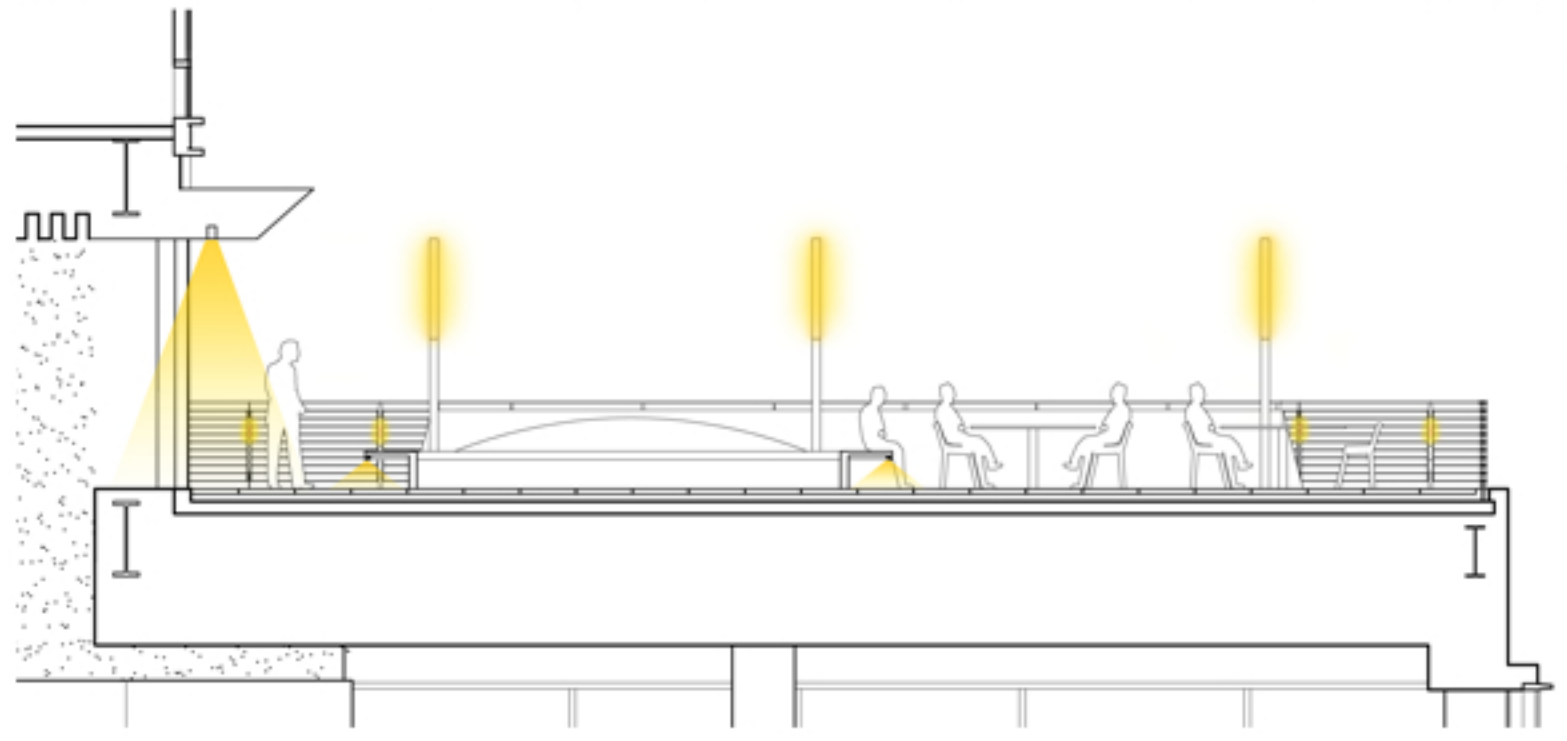
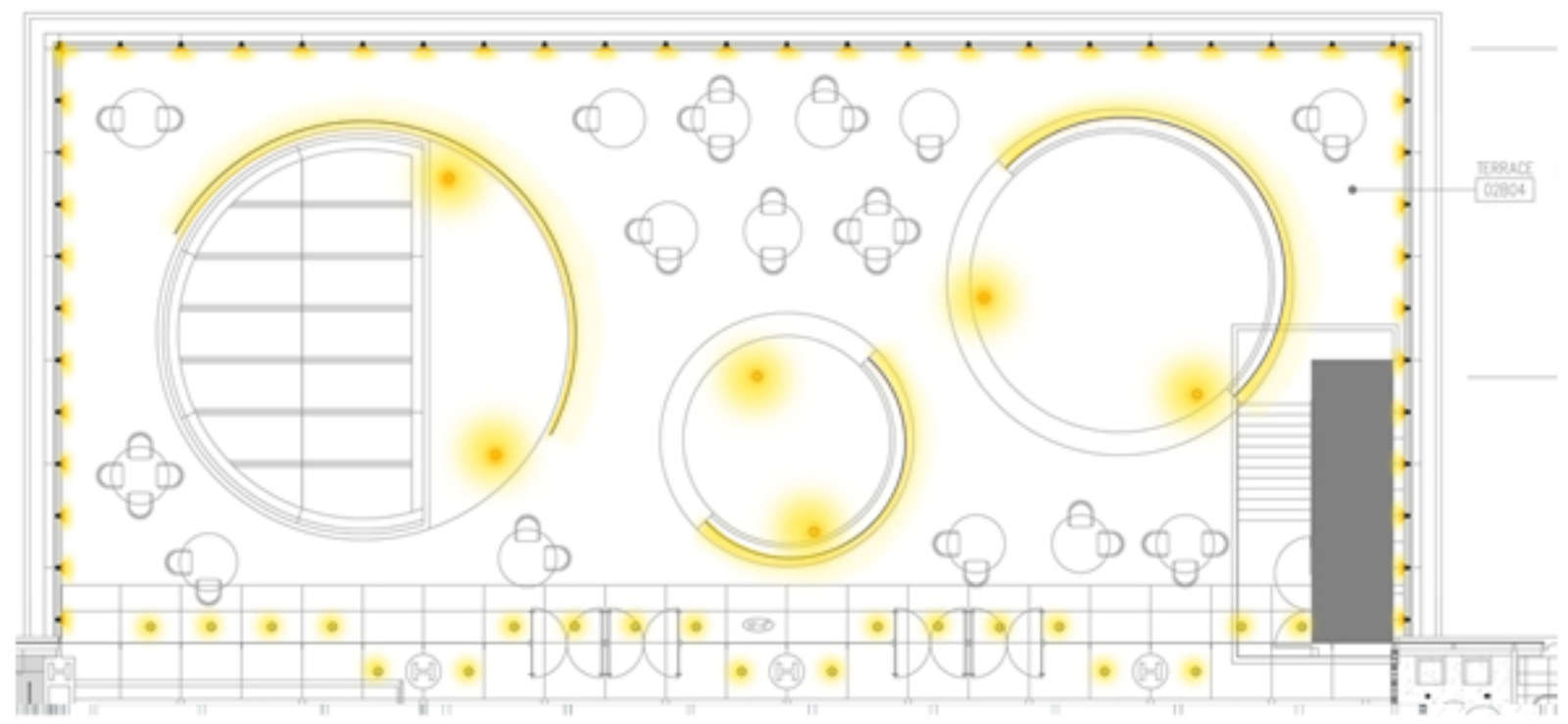

Pole Fixture Option

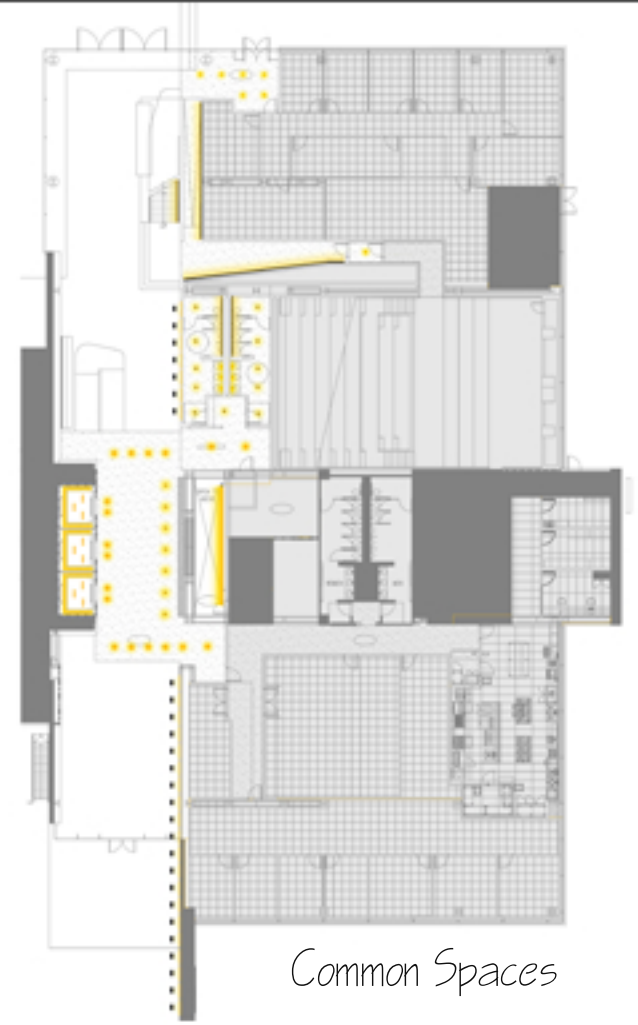

Common Spaces

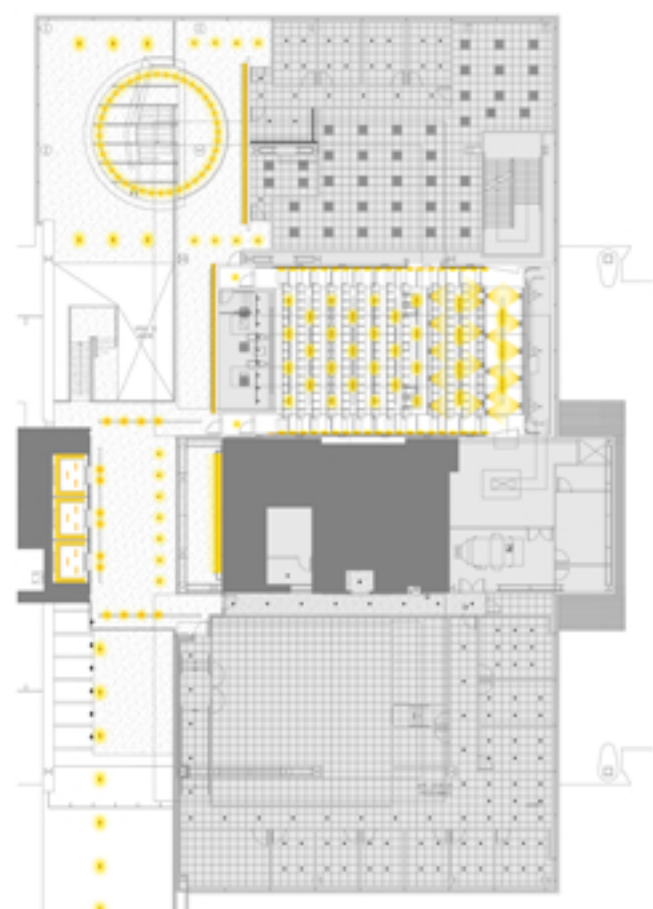

Screening Room, Lobby
and Conference Room



Typical Floor

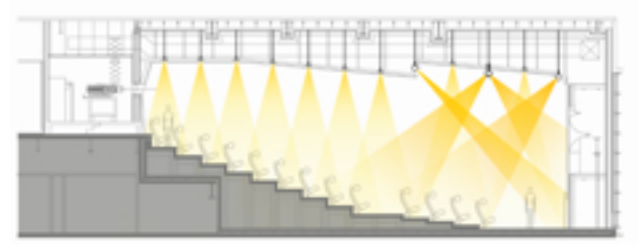

Screening Room Detail

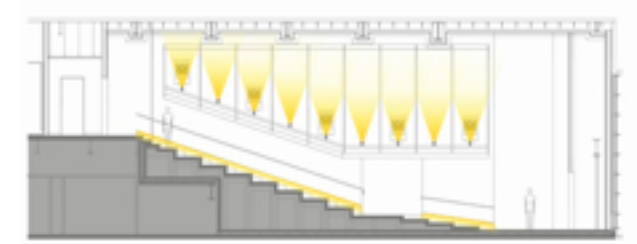

Screening Room Wall

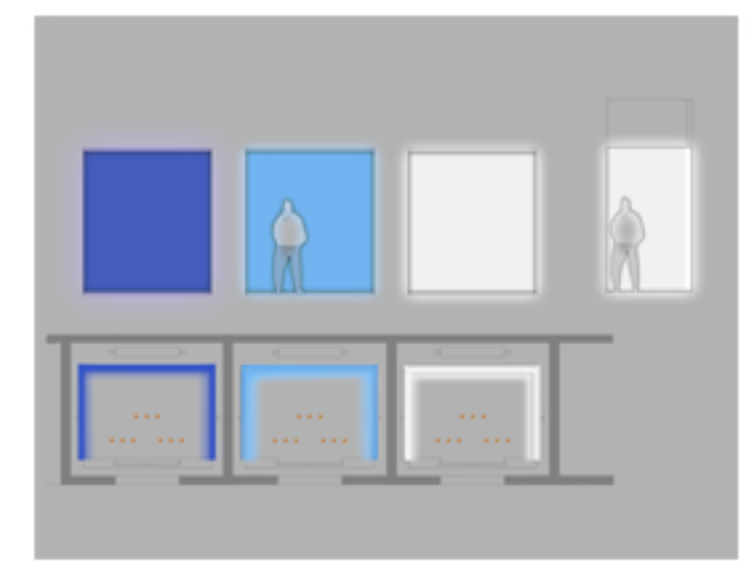

Glowing Elevator Concept





Original



Double Exposure



Double Exposure



Double Exposure with Color

Jennifer Gabbyelle Curley
JGC

Portfolio

Architectural Lighting Design



Personal Digital Photography

Jennifer Gabrielle Curley
JGC

Portfolio

Architectural Lighting Design

