

Simmons College School of Management Boston, MA



Kevin Wigton
AE Senior Thesis 2010

Simmons College School of Management
Expansion Design Scenario Study

Presentation Outline

- Building Information
- Existing Structural System
- Problem Statement
- Structural Depth Study
- Façade Study
- Construction Staging Study
- Conclusions and Recommendations



Building Information

Building Location

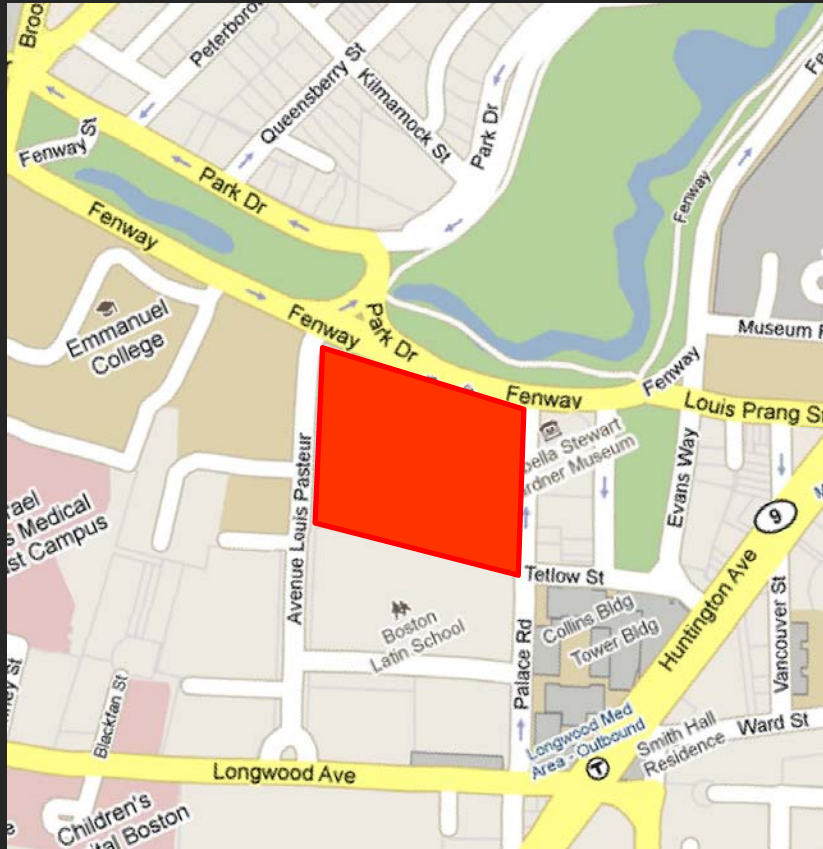

Building Information

Building Statistics

- Educational Facility
- 5 Story Below Grade Garage
- 5 Story Above Grade building
- 66,500 sf
- Completed: Fall 2008
- Cost: \$63 Million



Building Information

Project Team

- Owner: Simmons College
- Construction Manager
 - Lee Kennedy
 - Payton Construction
- Cannon Design Team
 - Architectural Design
 - Structural Engineering
 - Mechanical Engineering
 - Plumbing Engineering



Presentation Outline

- Building Information
- **Existing Structural System**
- Problem Statement
- Structural Depth Study
- Façade Study
- Construction Staging Study
- Conclusions and Recommendations



Existing Structural System

Parking Garage

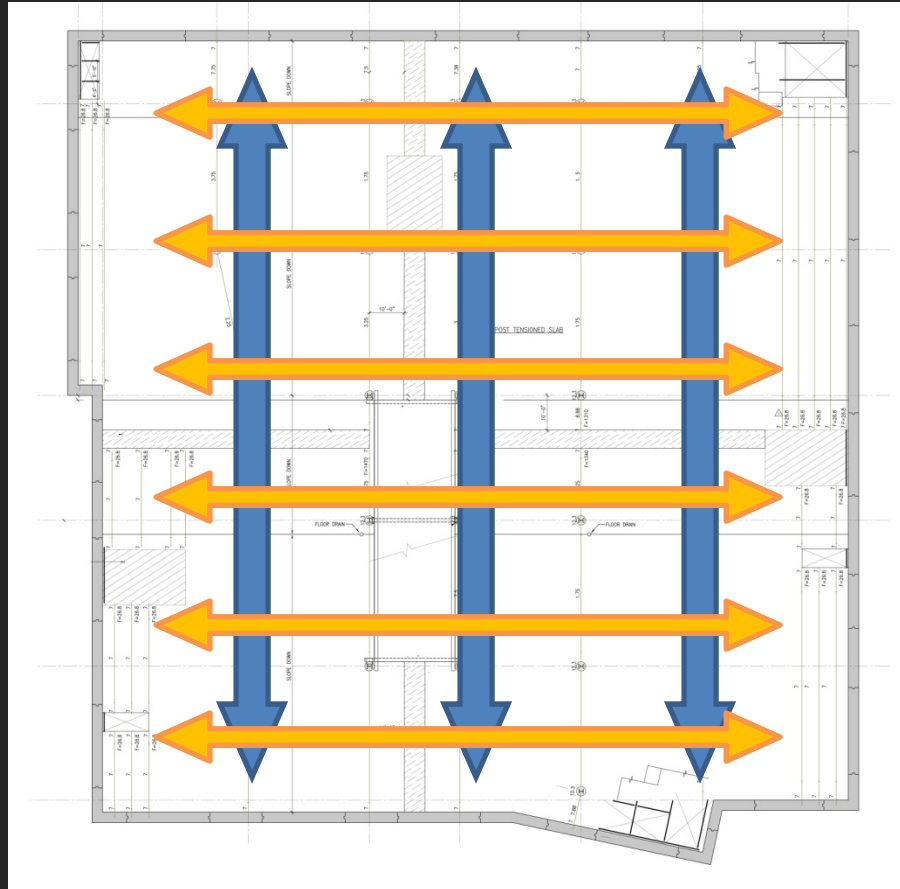

Existing Structural System

Plaza Level Transition

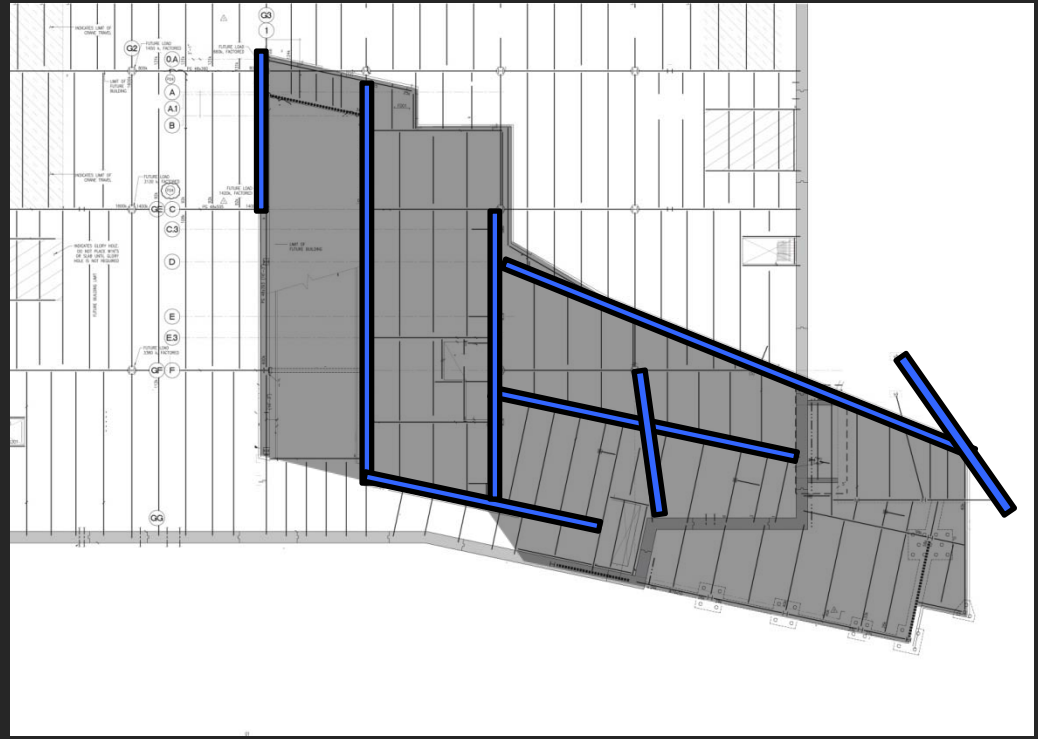
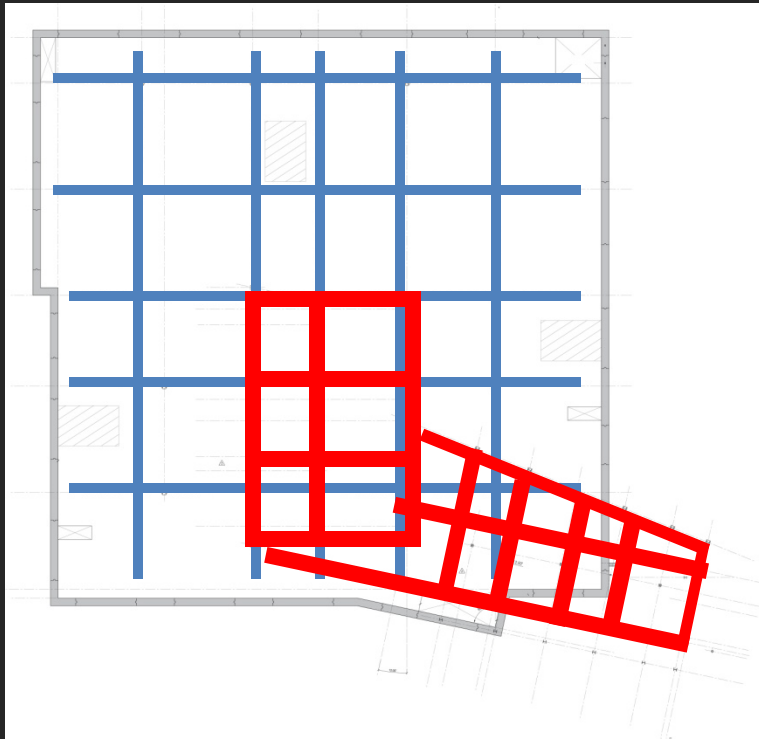

Existing Structural System

Above Grade Building: Gravity System

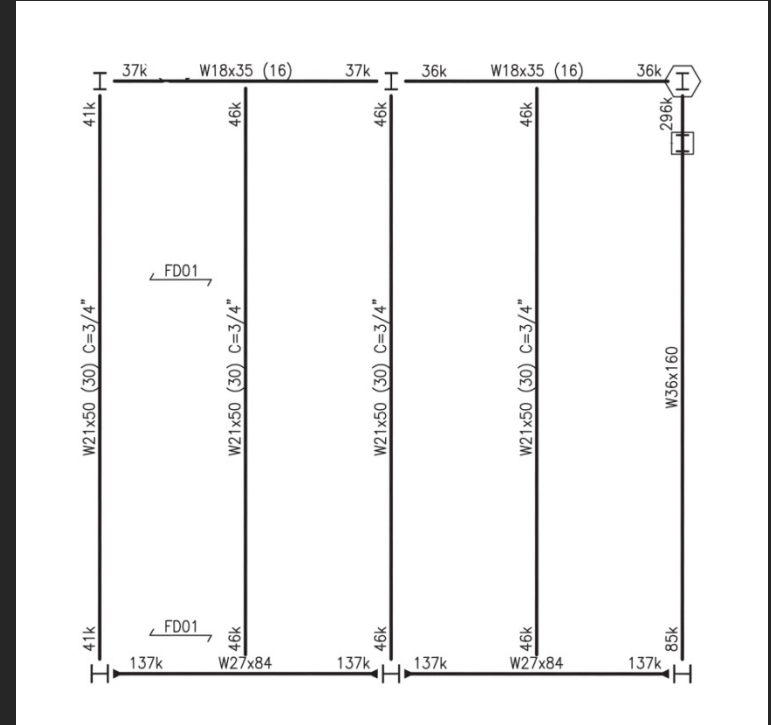
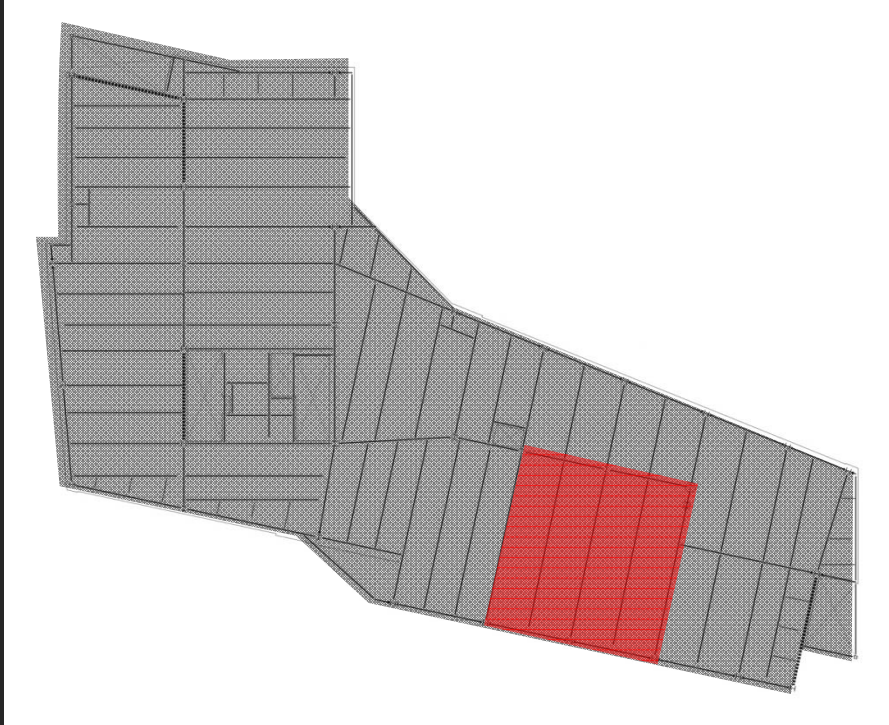

Existing Structural System

Above Grade Building: Lateral System

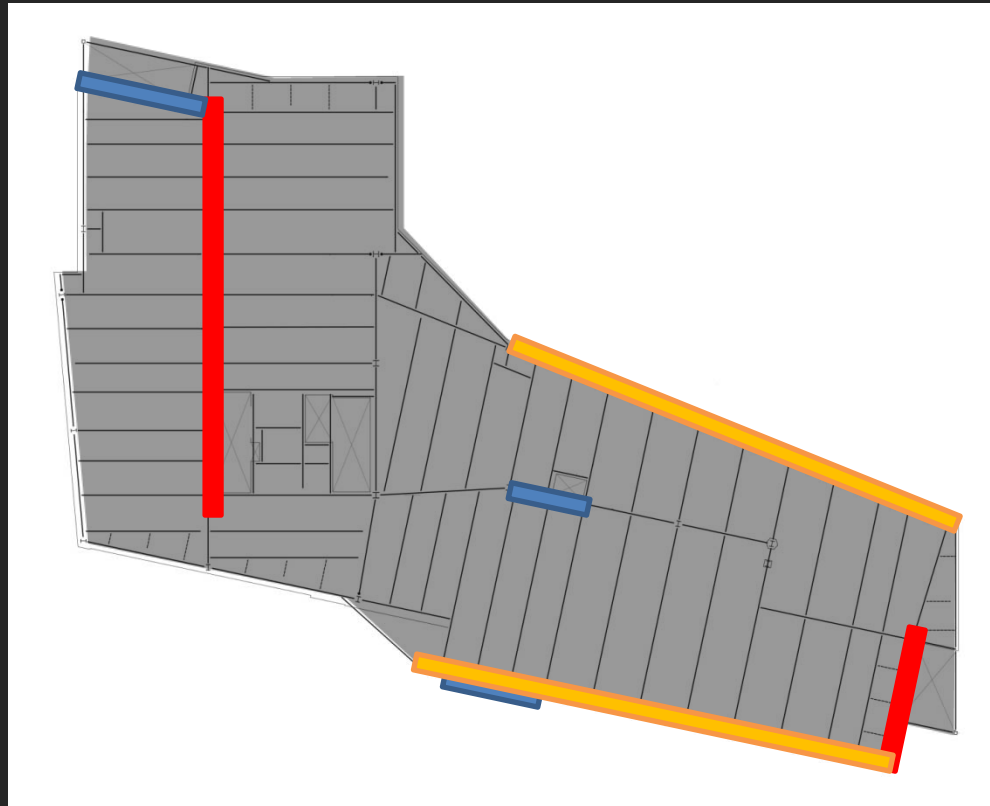

Presentation Outline

- Building Information
- Existing Structural System
- **Problem Statement**
- Structural Depth Study
- Façade Study
- Construction Staging Study
- Conclusions and Recommendations



Problem Statement

Building Expansion: Criteria and Provisions



Problem Statement

Building Expansion: Criteria and Provisions



Problem Statement

Building Expansion: Additional Design Scenario



Project Goals

- Provide an Additional Design Option for the Building Expansion
- Implement Structurally Tied Expansion Layout
- Revise Lateral System to Resist Load Effects for Base and Expanded Building
- Ensure that the Base Building and Current Expanded Options are Not Compromised
- Provide a Constructable and Cost Effective Solution

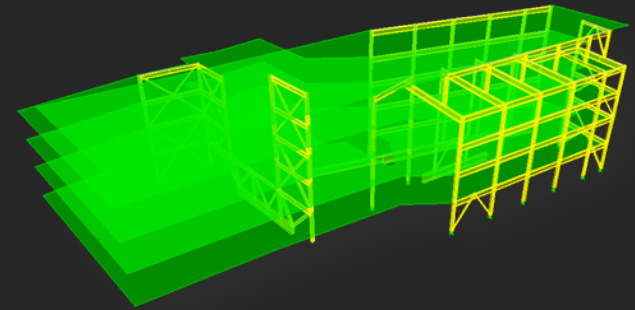
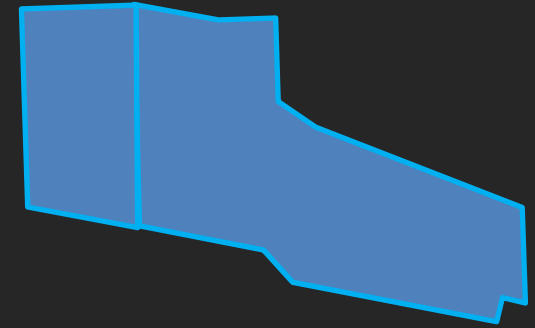

Presentation Outline

- Building Information
- Existing Structural System
- Problem Statement
- **Structural Depth Study**
- Façade Study
- Construction Staging Study
- Conclusions and Recommendations



Structural Depth Study

Design Criteria

- Resist Additional Loading Demands with Existing Lateral System Arrangement
- Reduce Torsional Effects Induced by Increased Eccentricity
- Reduce Accidental Torsional Effects Required in Load Analysis
- Design Expanded System to Meet Drift Requirements
- Meet All Structural Requirements for the Base and Expanded Systems



Structural Depth Study

Base Condition Modeling: Options

- Pinned Conditions
- Explicit Modeling of Entire Parking Garage
- Modeling of Key Transfer Elements with Vertical Stiffness Modifiers

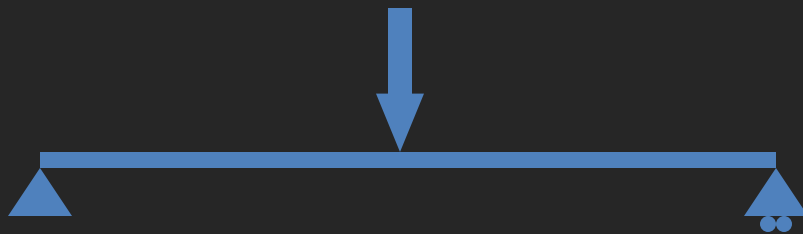

=



Structural Depth Study

Base Condition Modeling: Implementation



Structural Depth Study

Base Condition Modeling: Result

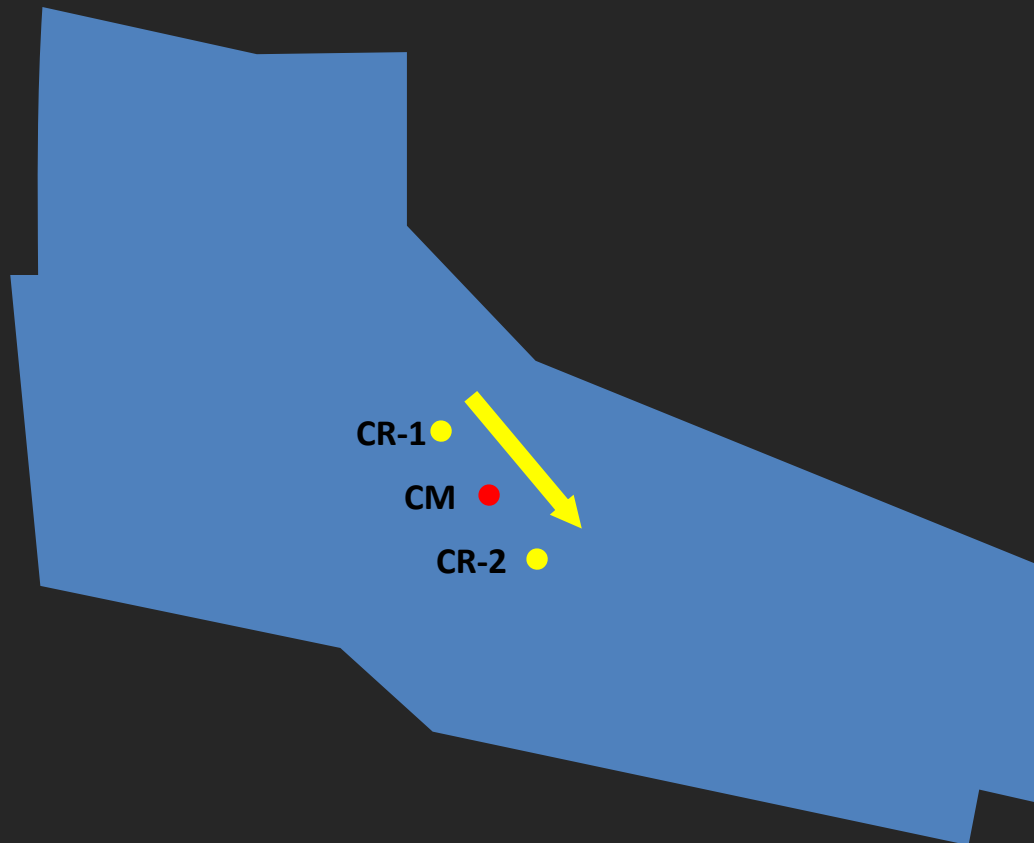

Structural Depth Study

Lateral System Study

Three Conditions To Consider

- Existing Structure
- Expanded System
 - Iterative Design Approach
- Revised Lateral System in Base Building Configuration

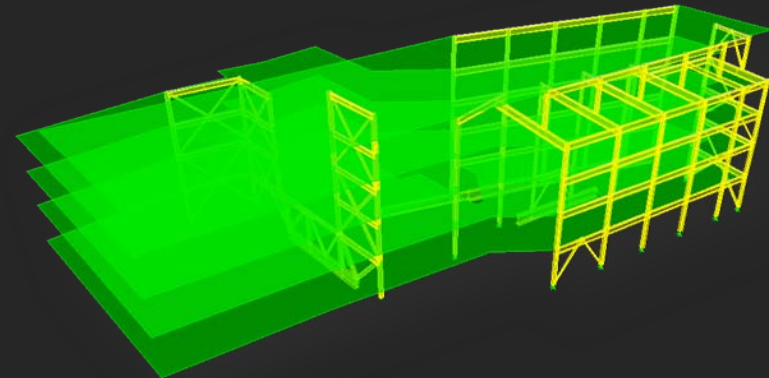
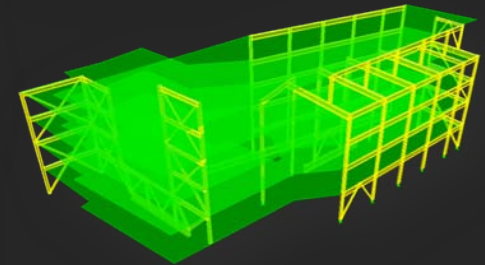
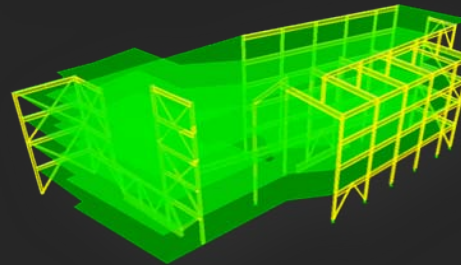

Structural Depth Study

Expanded Building System Properties

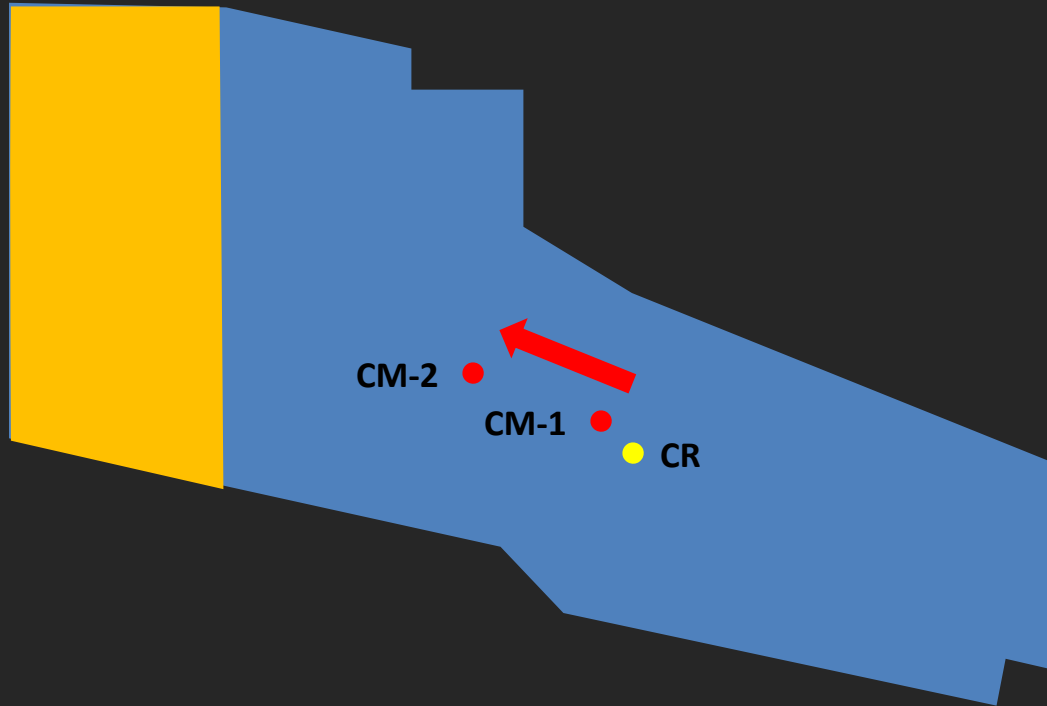

Structural Depth Study

Critical Loading on the Expanded Building

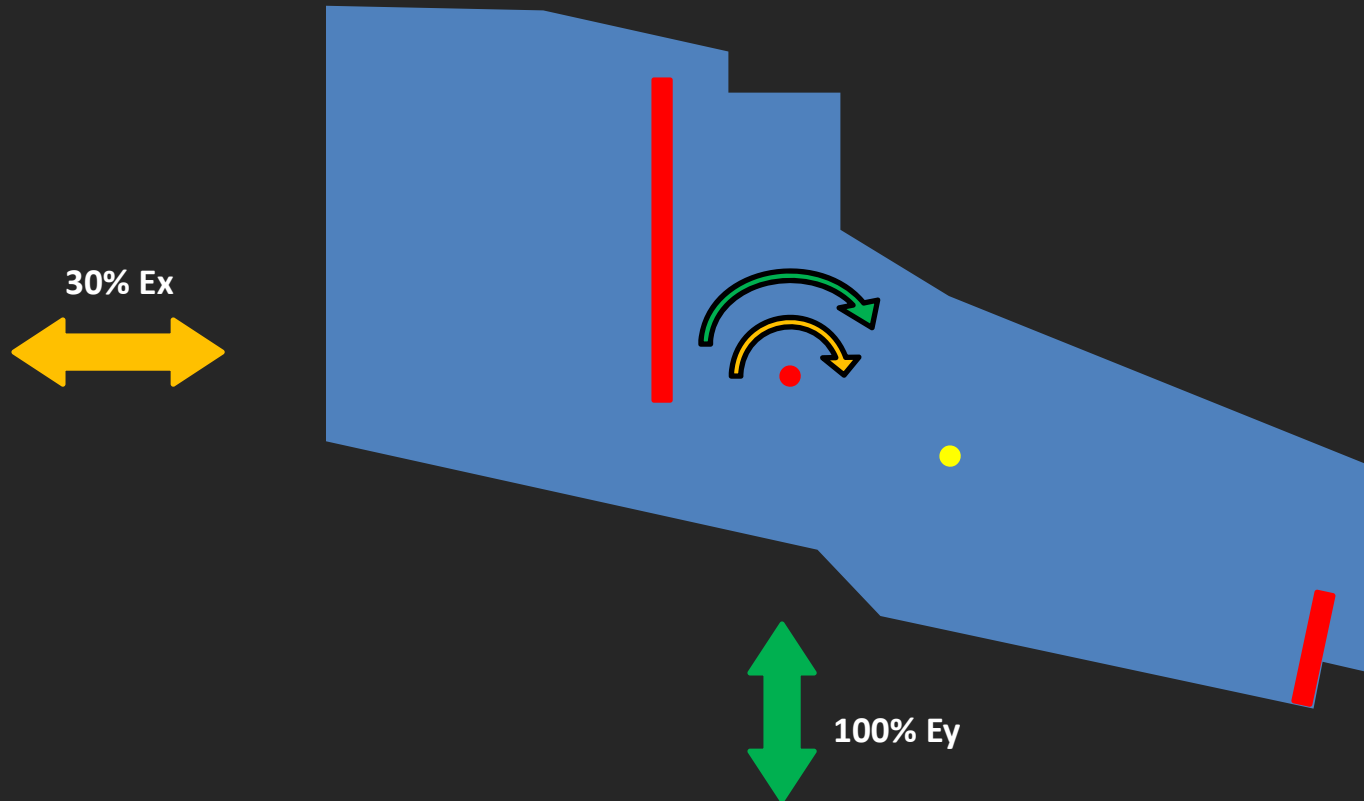

Structural Depth Study

Solution Method

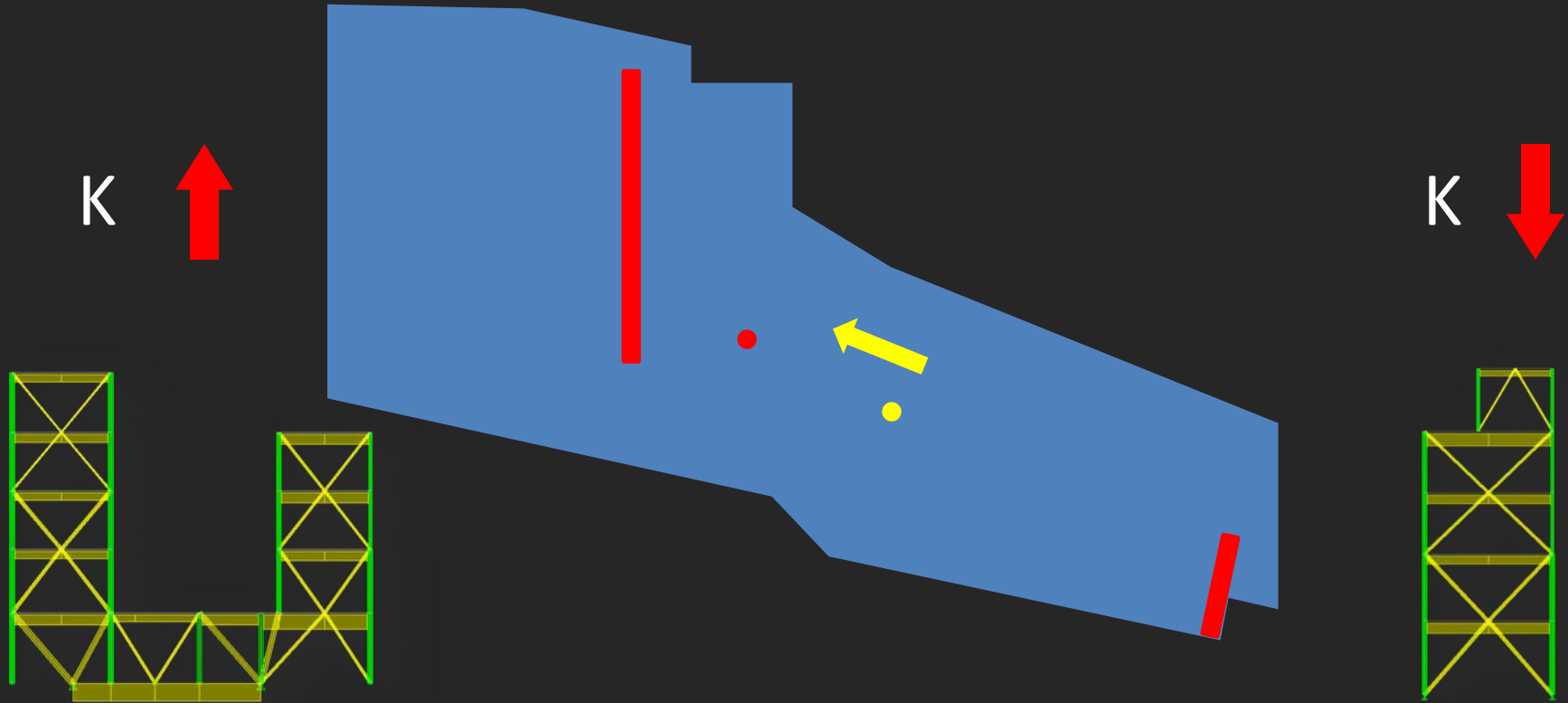

Structural Depth Study

Altered Load Effects Based on Revised Layout

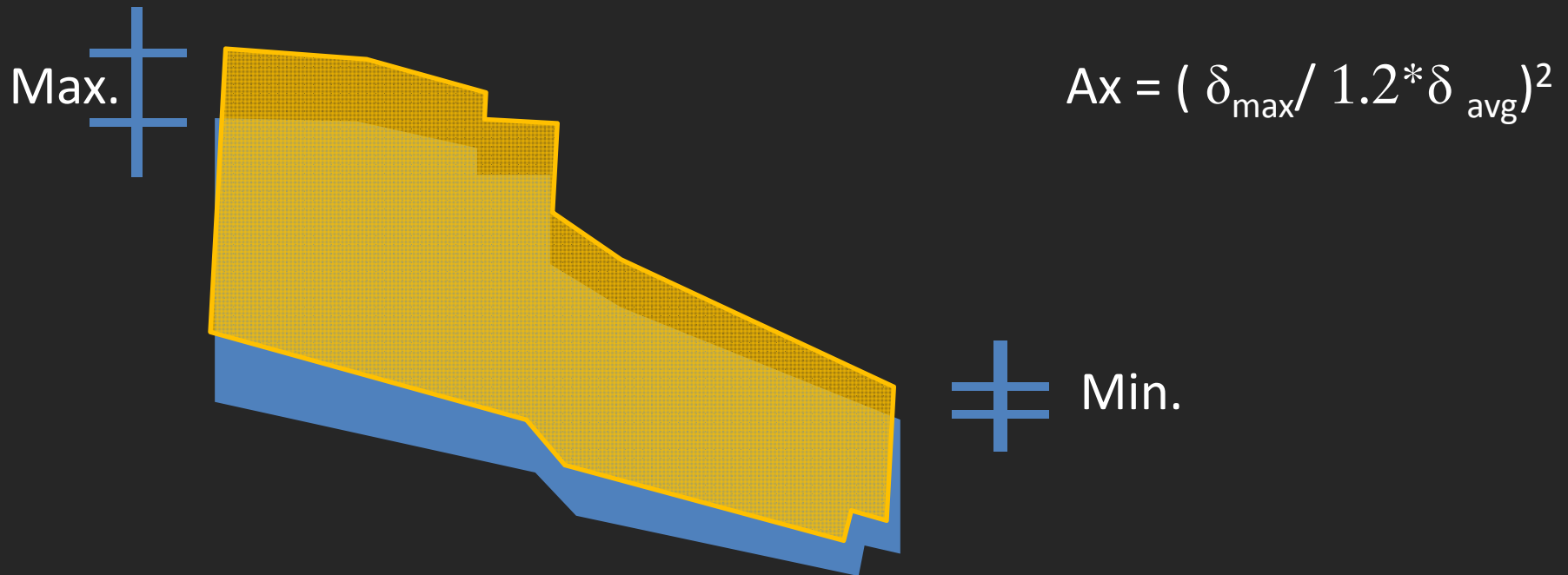

Structural Depth Study

Center of Mass vs.
Center of Rigidity
Summary (ft)

Story	Expanded System	New Expansion Design	Percent Reduction
5	30.4	24.8	18.2
4	49.7	38.7	22.2
3	45.2	34.0	24.9
2	40.8	24.8	39.2
1	20.8	7.4	64.3
		Average	33.8

Amplified Torsional
Moment Factor

Story	Expanded System	New Expansion Design	Percent Reduction
5	2.46	2.34	4.9
4	2.49	2.34	6.0
3	2.47	2.32	6.1
2	2.46	2.27	7.7
1	2.39	2.14	10.5
		Average	7.0

Structural Depth Study

Solution Summary

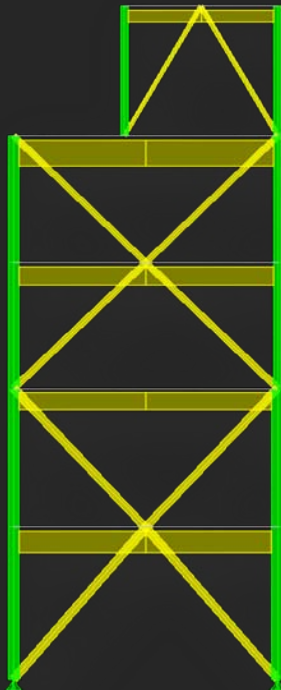

HSS6x6x3/8	to	HSS6x6x1/4
HSS8x8x3/8	to	HSS6x6x1/4
HSS8x8x3/8		Unchanged
HSS10x10x3/8	to	HSS8x8x1/2
HSS10x10x3/8	to	HSS8x8x1/2

Structural Depth Study

Solution Summary

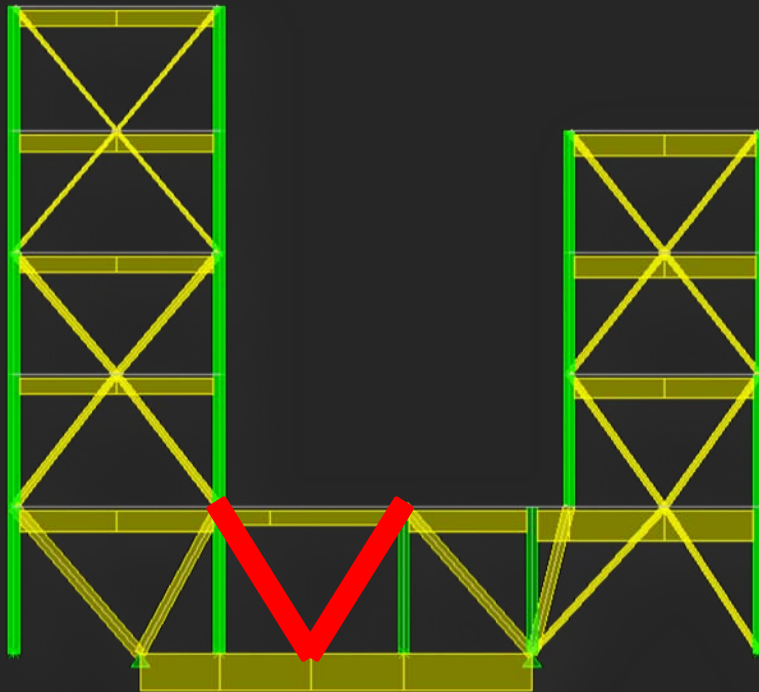
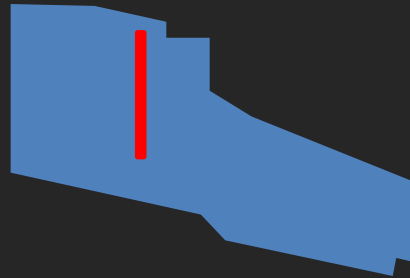

Original Design
HSS8x8x5/8

New Design
HSS10x10x5/8

Structural Depth Study

Connection Requirements

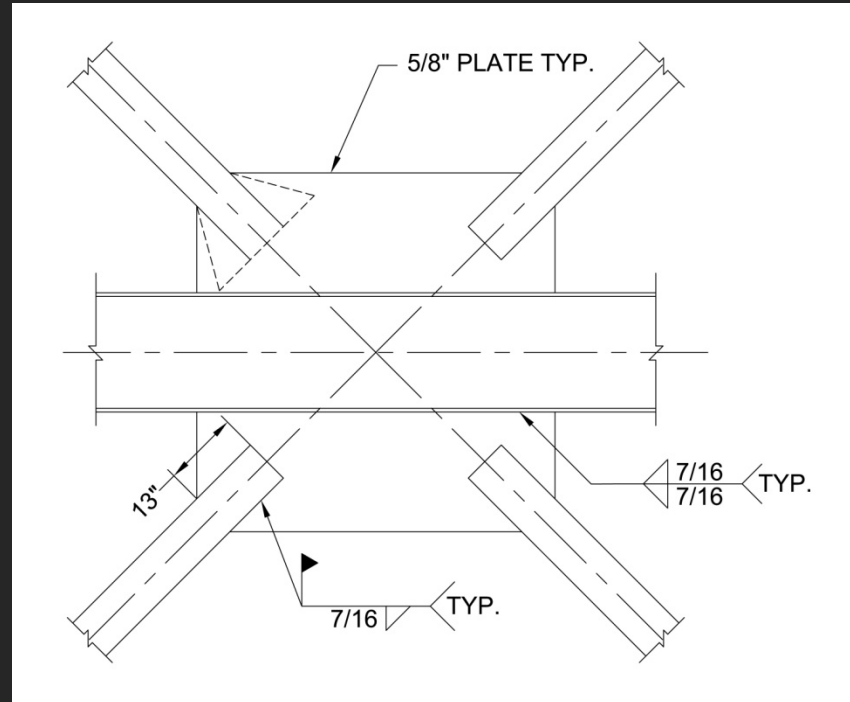
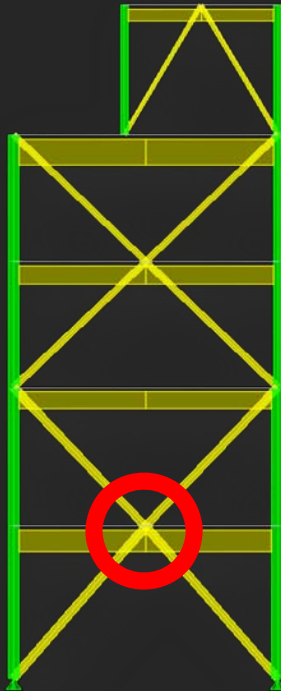

Structural Depth Study

Seismic Drift Summary: X-Direction

Story	Base Building	Expansion Design	Revised Base	Limit
5	0.45	0.59	0.54	1.5
4	0.50	0.82	0.58	1.5
3	0.51	0.78	0.60	1.5
2	0.48	0.71	0.55	1.5
1	0.28	0.41	0.30	1.5

Structural Depth Study

Seismic Drift Summary: Y-Direction

Story	Base Building	Expansion Design	Revised Base	Limit
5	0.54	1.23	0.69	1.5
4	0.53	1.19	0.68	1.5
3	0.50	1.14	0.65	1.5
2	0.43	0.97	0.54	1.5
1	0.19	0.31	0.23	1.5

Structural Depth Study

Final Note: Diaphragm Forces



Presentation Outline

- Building Information
- Existing Structural System
- Problem Statement
- Structural Depth Study
- **Façade Study**
- Construction Staging Study
- Conclusions and Recommendations



Façade Study

Drift Limitation Check

New Max Drift = 1.23%

2' x 11' Window

Clearance = 1/4"

4' x 13' Window

Clearance = 3/8"

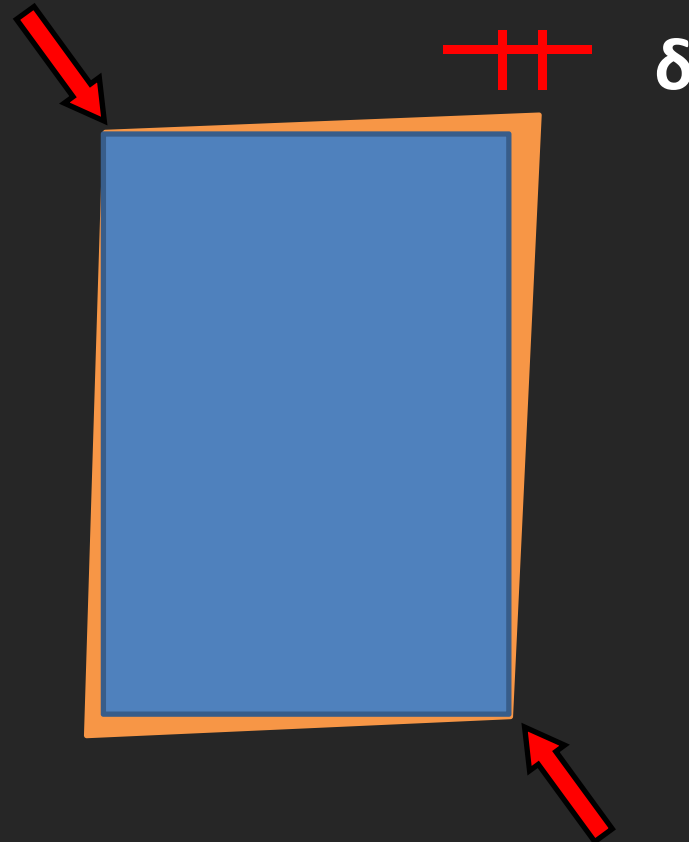

Façade Study

Façade Connection West Wall

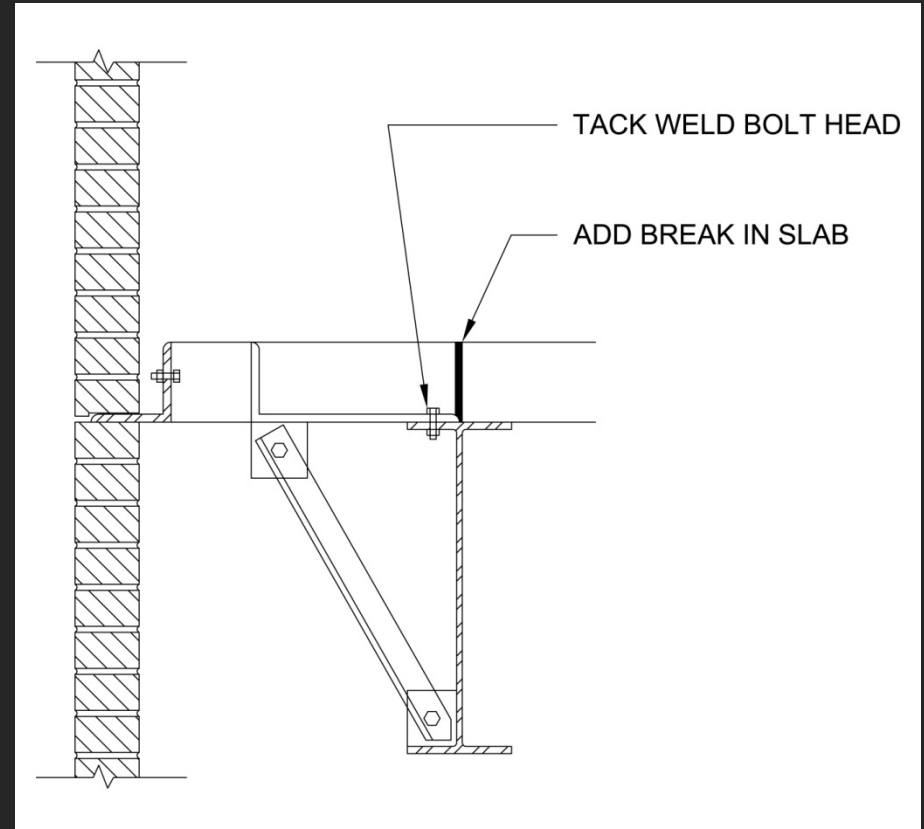
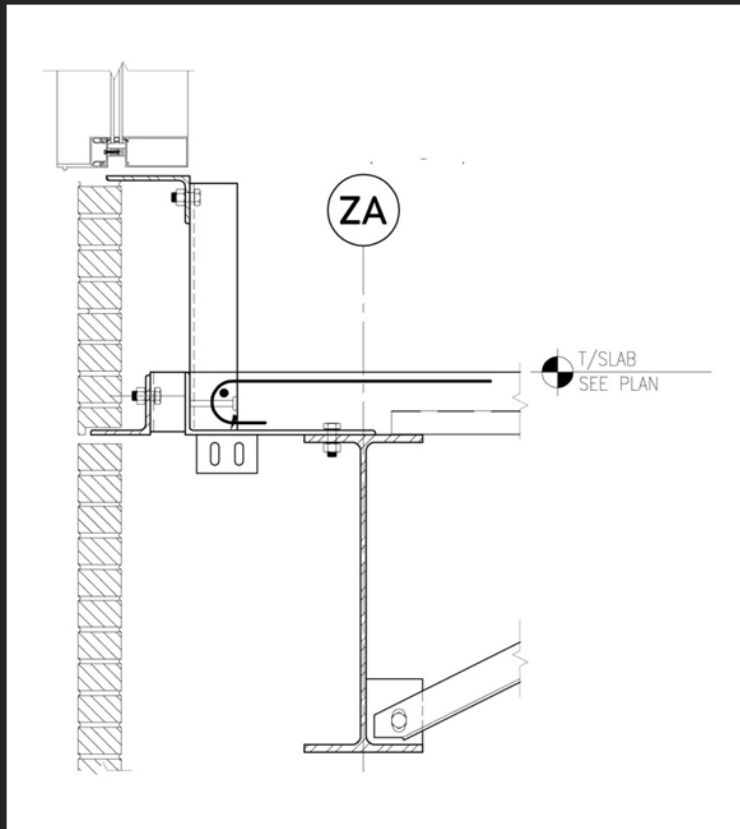

Presentation Outline

- Building Information
- Existing Structural System
- Problem Statement
- Structural Depth Study
- Façade Study
- **Construction Staging Study**
- Conclusions and Recommendations



Construction Study

Site Constraints



Construction Study

Site Constraints

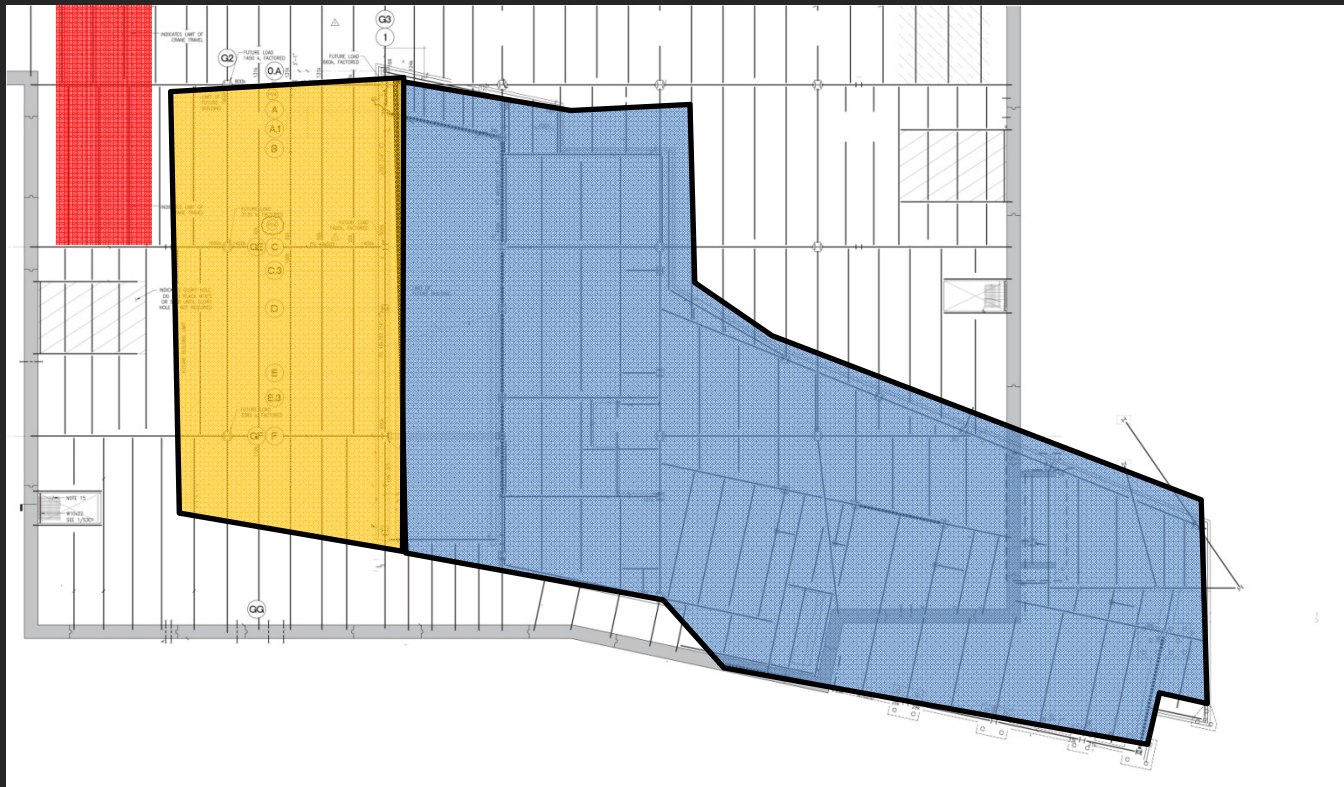

Construction Study

Site Layout and Requirements

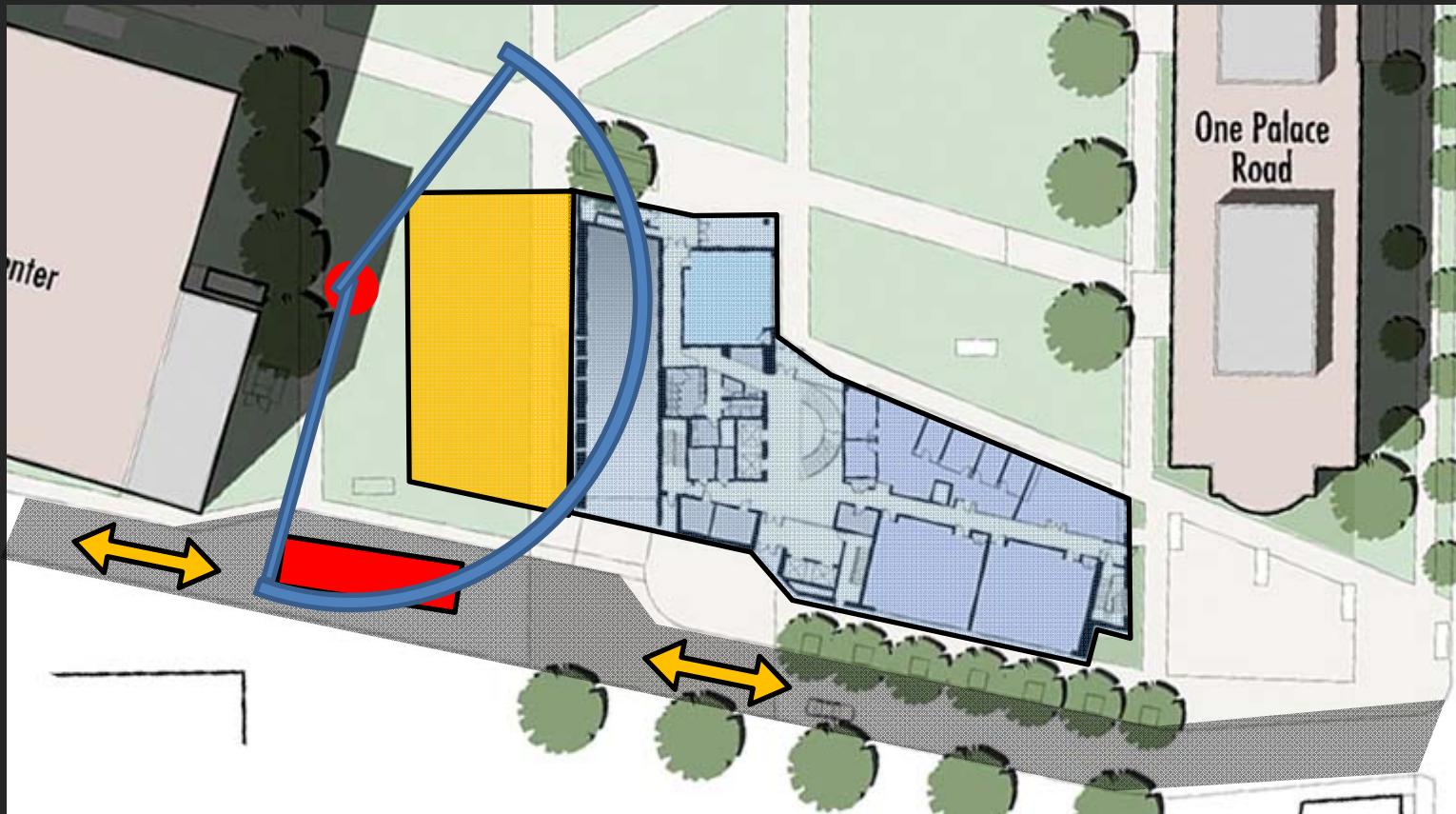

Presentation Outline

- Building Information
- Existing Structural System
- Problem Statement
- Structural Depth Study
- Façade Study
- Construction Staging Study
- **Conclusions and Recommendations**



Conclusions and Recommendations

Conclusion

- Redesigned Structural System Meets Structural Code Requirements in both Base and Expanded Structure
- Façade Detailing Necessary to Accommodate Increased Seismic Story Drift in Expanded Layout
- Modified Façade Connection Detail Allows System Constructability
- Construction Staged within Current Site Conditions
- Additional Expansion Scenario Feasible

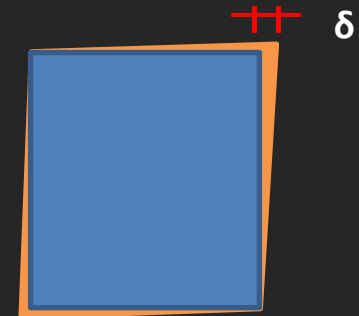
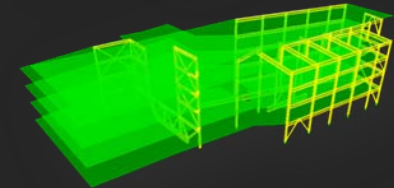
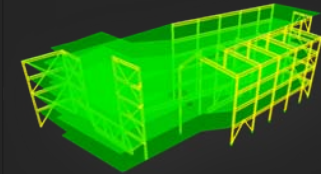

Acknowledgements

Cannon Design

Kellie Farster

John Boekelman

Lynne Deninger

Fletcher Clarcq

Professional Consultants

Charlie Carter

Robert McNamara

Faculty Advisor

Professor Parfitt

AE Faculty

Dr. Geschwindner

Dr. Lepage

Dr. Memari

Gaby Issa-El-Khoury

A Special Thanks to:

Close Friends and Family for the Continued Support

Questions



Kevin Wigton
AE Senior Thesis 2010

Simmons College School of Management
Expansion Design Scenario Study