

# 800 NORTH GLEBE

Arlington, VA

## Final Report



Ryan Johnson

Structural Option

Advisor: Dr. Linda Hanagan

Spring 2010

# 800

## NORTH GLEBE

◆◆◆◆◆

### GENERAL BUILDING DATA

Location: Arlington, VA  
Occupant: Up for Lease  
Occupancy Type: Mixed-Use Office  
Size: 316,000 SF  
10 Stories + 1 Penthouse and  
3 Below Grade Parking Levels  
Completion Date: 2011  
Delivery Method: Design-Bid-Build  
Contract Type: At Risk  
Project Cost: \$62 Million

### PROJECT TEAM

Owner: The JBG Companies  
Architect: Cooper Carry  
Landscape Architect: Bowman Construction  
Structural Engineer: Structura  
Civil Engineer: Bowman Construction  
MEP: Girard Engineers  
Contractor: Clark Construction Group LLC

### MEP SYSTEMS

- 9 VAV 30,000-37,000 cfm airhandling units: 1 per level
- 3 800 gpm cooling towers with one chilled water free cooling heat exchanger
- 480/277 V electrical distribution system carried by a 3000 A busway
- Surface mounted and recessed fluorescents, and wall mounted CFLs fixtures throughout the building
- Occupancy sensors installed on all office levels
- 450 KW emergency generator powering lights, fire pumps, sump pumps and stairwell pressurization fans

### ARCHITECTURE

- Three sail-like sweeping glass curtain walls
- Precast concrete panels, decorative stone and metal cladding adorn the facade
- Vertical and horizontal precast bands create sight lines
- Building geometry defined by radial lines and circles
- Ground level retail offering 14'-6" ceiling heights with floor-to-ceiling glazing
- Diamond expression decorative composite metal canopy with backlit glass over main retail entrance
- Building setbacks located at levels 4, 6 and 8
- Numerous amenities located on-site: Retail, restaurant, cafe, fitness center.
- Designed for LEED Gold Certification

### STRUCTURAL SYSTEMS

- Three levels of substructure used for parking
- Post-tensioned girders with 9" thick one-way slab allowing for 30' x 46' open bay design on levels 2 - 10
- 10.5" two-way slabs used for building stepouts below level 6
- Lateral resistance provided by two 12" thick "C" shaped shear walls at the buildings core
- Column size variation from 12" x 24" to 30" x 30" with a singular round 36" dia. column at entrance
- Foundations range in size from 4'-0" square up to 14'-0" square with caissons supporting where applicable
- Lowest level parking garage has a 4" thick SOG



# Table of Contents

Executive Summary.....	6
Acknowledgements.....	7
Introduction .....	8
Architectural Overview .....	9
Existing Structural System Overview .....	11
Foundation.....	11
Superstructure .....	11
Lateral System.....	13
Existing Structural System Analysis.....	15
Deflection Criteria.....	15
Materials .....	16
Design Process – Gravity System .....	17
Design Process – Lateral System.....	18
Problem Statement.....	20
Problem Solution .....	20
Design Goals.....	21
MAE Course Related Study .....	21
Structural Depth Study .....	22
Design Codes and Standards.....	22
Material Properties.....	23
Slab Design .....	24
Design Loads .....	24
Design Process – Initial Layout.....	25
Design Process – Computer Model.....	27
Design Process – Analysis and Detailing.....	30
Lateral System Optimization Design .....	36
Design Loads .....	37
Design Process – Load Path and Distribution .....	48

Design Process – ETABS Computer Model.....	49
Design Process – Rigidity and Relative Stiffness.....	50
Design Process – Torsion .....	52
Design Process – Shear .....	53
Design Process – Drift and Displacement .....	54
Column Design .....	56
Design Loads .....	56
Design Process – Strength Calculation and Detailing.....	57
Foundation Impacts .....	60
Overturning and Addition Building Weight .....	60
System Comparison and Conclusion.....	61
Architectural Breadth .....	62
Floor Plan Redesign.....	62
Design Process .....	62
Building Envelope Study .....	67
Existing Glass Façade Study .....	67
Modification Recommendations and System Detailing .....	68
Construction Management Breadth.....	69
Sequencing Study.....	69
Existing Building Schedule .....	70
Thesis Design Schedule.....	71
Cost Study .....	72
Existing Building Analysis .....	73
Thesis Design Analysis.....	73
Construction Management Conclusion .....	74
Final Conclusion and Recommendations.....	75
Bibliography .....	76
Appendix A: List of Figures.....	77
Appendix B: List of Tables .....	79

Appendix C: Slab Design.....	80
Appendix D: Column Design .....	99
Primary Column Design.....	100
Sloped Column Design .....	103
Appendix E: Lateral System Design.....	87
Wind Determination Calculations.....	87
Seismic Determination Calculations .....	92
Story Drift and Displacement.....	98
Appendix F: Building Envelope Study .....	99
Glazing Calculations .....	107
Anchor Determination .....	112
Appendix G: Sequencing Study.....	113
Existing Building Schedule .....	113
Thesis Redesign Schedule .....	114
Appendix H: Cost Study.....	115
Existing Building Cost .....	115
Thesis Redesign Cost.....	116

## **Executive Summary**

The thesis study performed for 800 North Glebe examined the design implications of changing the current slab system to a two-way post-tensioned system and the affects it will have on the lateral force resisting system. To employ an alternative slab system in the building, the bay sizes were reduced from a 30'-0"x46'-0" grid to a 30'-0"x23'-0" grid, thus increasing the total column quantity. The column sizes were reduced on the upper seven levels from 30"x30" to 24"x24". Column grids aligned one another in the superstructure levels, but the interface to the below level parking garage required sloping a row of columns on the first level and adding a corbel-transfer beam system on the first subgrade floor.

The existing system consists of a 9" mildly reinforced one-way slab cast over wide-shallow post-tensioned girders with two "C" shaped core shear walls resisted the lateral load imposed on the structure. The structural depth redesign implemented two-way post-tensioning of an 8" flat slab with banded tendons in the east-west direction and distributed tendons in the north-south direction. Tendons banded over the column strip were analyzed to act as beams within a concrete moment frame. This permitted the lateral force resisting system in the east-west direction to be analyzed as a dual system; a concrete moment frame along with the shear wall core. However, since the code does not specifically address post-tensioned systems as lateral resisting, doctoral research papers were consulted for analysis and recommendations.

Changing the column grid unquestionably affected the architectural floor plans of the building. The existing layout was studied to determine the proper size of rentable offices and workstations and great effort was made to keep the same ratios. So as to not diminish the number of offices available, interior partition walls being moved around were kept to a minimum. Final floor plan redesigns maintained the same quantity of workstations and offices, while meeting all applicable egress codes.

A large part of the buildings appeal is the glass curtain wall sail which spans the entire building, from the ground level retail space to the tenth level offices. Calculated wind pressures from the depth study were used in analyses and it was determined that the 7'-7 ¼" x 5'-0" glass plies and the aluminum mullions were adequately sized to meet all deflection criteria.

The second breadth topic conducted was construction management sequencing and cost analysis of the structural system for both the existing design and the thesis redesign. Because 800 North Glebe is a spec office building, immediate revenue upon completion is a primary concern. The original system was concluded to be more time and cost effective; taking 43 days as compared to 94 days, and costing nearly \$684,000 less.

## **Acknowledgements**

The author wishes to extend his thanks to the following professionals, AE faculty and individuals for their guided assistance and generosity throughout the year with this thesis project.

### **Structura**

Mark Erdman  
Ryan Sarazen  
Caitlyn Mueller  
The entire Structura staff

### **The JBG Companies**

Adam Peters

### **Cooper Carry**

Katie Peterschmidt

### **The Pennsylvania State University**

Dr. Linda Hanagan  
Professor M. Kevin Parfitt  
Professor Robert Holland  
Professor Paul Bowers  
The entire AE faculty and staff

### **Holbert Apple Associates, Inc.**

Mr. Richard Apple, P.E.

He would also like to say a special thank you to his parents, Eric and Margy Johnson, and his family and friends. Everything he has accomplished over the past five years could not have been possible without your love and support.

# Introduction

Located in the Ballston district of Arlington, VA, 800 North Glebe offers class-A mixed-use office space and one level of public space. Three levels of below grade parking are shared between 800 N. Glebe and 900 N. Glebe: Virginia Tech’s new research facility. Vertical transportation of stairways and elevators bring you from the garage to the large open retail and gathering space. Levels two through ten provide open plan office space. Column spacing of 30’ x 46’ allows for 30,000 square foot floor plates with 9’-0” floor-to-ceiling heights. Building setbacks are located at levels four, six, and eight to aesthetically vary the building and offer different office layouts as seen in Figures 1 through 4.



Figure 1: Floor Level 3



Figure 2: Floor level 5

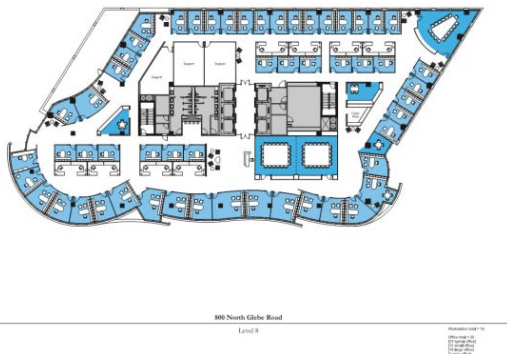

Figure 3: Floor level 8



Figure 4: Floor level 10



## Architectural Overview

800 North Glebe is a 10-story 316,000 square-foot iconic commercial building. Retail and public gathering spaces are located at street level in the 2-story lobby of the building. The remaining nine levels will provide class-A mixed-use offices. 800 North Glebe was designed for LEED Gold Certification by utilizing numerous strategies to minimize its carbon footprint.



Figure 3: South-East Facade

Innovative sustainable and responsible design practices are one of the designer's primary goals. Integration of sustainability and every day design by minimizing the carbon footprint, balancing energy, resources and feasibility all went into design on 800 North Glebe. In accordance with the U.S. Green Building Council's Leadership in Energy and Environmental Design, the owner has a goal to achieve LEED Gold Certification, which the designers fulfilled. LEED Gold Certification

requires the design to attain at least 34 out of 61 possible points.

The 10-story façade, created by three sail-like sweeping glass curtain walls, accentuate the sight lines of the building. Radial lines and circles were widely used to define the crown and drum feature of level one and the sail feature of the remaining levels. Refer to Figure 5, 6 and 7 for visual representation of façade features.

Retail and community spaces on the ground level offer 14'-6" ceiling heights with floor-to-ceiling glazing. Over the main building entrance, there is a diamond expression decorative composite metal canopy with a plaster soffit and sunguard ultrawhite laminated backlit glass as shown in Figures 5 and 6. Offices on the remaining levels offer 9'-0" floor-to-ceiling heights.



Figure 4: Sail Feature

Three types of Architectural precast panels, metal cladding and glazing will adorn 800 North Glebe's façade. The large sail-like curtain wall consists of Viracon VRE 1-46 on insulated heat strengthened vision and spandrel glass with PVD finished custom color composite metal mullions. Along the street level, one will find a variety of stone, metal and glazing. These include Oconee granite with a polished finish at the base, insulated spandrel glass, precast concrete panels with a light sandblast finish and PVDF finished aluminum louvers.



Figure 5: Front View

Vertical bands rising up the building are made of precast concrete panels with a medium sandblast finish while horizontal bands consist of exposed aggregate finished panels. Other glazing found on the building is sunguard supernatural-68 on ultrawhite insulated glass and Viracon VRE 1-46 on insulated punch vision glass.



Figure 6: Canopy Over Main Entrance

Protection from the elements on the roof is provided by the composite roof membrane. The composite consists of R-19 high density rigid insulation, protection board, and fully adhered 60 mil TPO membrane on top of a structural concrete slab. Where the roof system terminates at a curtain wall, fluid applied waterproofing is placed atop drainage board.

## **Existing Structural System Overview**

### **Foundation**

Geotechnical studies performed by ATC Associated Inc., reported site and subsurface conditions encountered and the following information details their geotechnical recommendations for the project. Three levels of parking make up the substructure of 800 N. Glebe, at roughly thirty feet below existing grade. Groundwater levels were encountered at depths ranging from approximately 22' to 37' below the existing ground surface.

Gravel, sand, silt and clay comprise the underlain site between existing elevation and bedrock, located 35.7' to 58.8' below existing ground surfaces. The analysis indicated that spread footing foundations bearing on the dense residual soil would be feasible for a majority of the structure. However, under interior wall, the foundation shall be designed with minimum widths of 18" to 24", where many are designed to be 12'x12'x6'. Below the ground level lobby area, caissons needed to be a minimum diameter of 60" and a mat foundation would be sufficient when designed for a maximum allowable bearing pressure of 3.5 ksf.

3 ksi normal-weight concrete (NWC) is used for the foundations and interior slab on grade, the garage slab-on-grade (SOG) uses 4.5 ksi NWC and the cellar columns are composed of 4 ksi and 8 ksi. Reinforcing varies in size throughout the footings and caissons, depending on thickness. A large mat foundation is located below the shearwalls at a thickness of 6'-0".

### **Superstructure**

A 4" thick SOG is located near the main entrance of the retail lobby. A 24" wide x 30" deep turndown, reinforced with #5s, surrounds the perimeter of the SOG. The ground level retail includes a 10" thick one-way slab with 10'-0"x10'-0"x5.5" drop panels support around the columns for punching shear resistance. Plaza slabs are 12" thick with 10'-0"x10'-0"x12" drop panels. Concrete strengths for the ground level include 3 ksi (SOG), 5 ksi (plaza slabs and framed interior slabs) and 4, 6 & 8 ksi (superstructure columns). Reinforcement for the SOG includes 6x6-10/10 welded-wire-fabric, while the one-way slab is reinforced with #5, #6 and #7s.

The remaining levels of the superstructure employ a one-way slab over post tensioned girders for the majority of the slab area which is represented as yellow in Figure 7. Girders range in size from 48" wide x 18" thick to 72" wide x 20" deep. Post tension tendons are ½" diameter with .153 square in. area low-relaxation strands with an ultimate strength of 270 ksi. A minimum of two post tension cables pass through the column reinforcement in the direction of the girder. This allows for continuous force distribution from one span to another, spanning the East/West directions. For levels two through six, two-way mildly reinforced slabs, colored cyan in Figure 7.

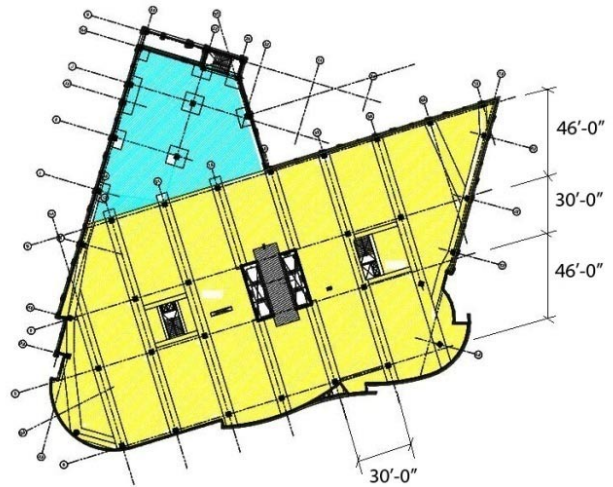

Figure 7: Slab Type Layout

Two-way slabs are 10.5" thick and are generally reinforced with #5 @ 10" in both directions. Drop panels in these areas are typically 10'-0"x10'-0"x7.5" to alleviate punching shear at the columns. Slabs over the 36" diameter column are 12" thick with #5 @ 12" parallel to the girder and #6 @10" perpendicular to the girders, due to the cantilever action.

Though the primary supporting material is concrete, steel shapes are used throughout the building for additional support. Elevator openings are supported by S8x18.4. HSS 6x3x1/4 were used as beams for additional support of shaft walls and W12x16s were used as elevator safety beams below the slabs. Steel allows for easy attachment of elevator rails and differential shaft openings.

## Lateral System

Shear walls in the core of the building provide the entire lateral support, as designed by the engineer, as seen in Figure 8. However, since the building primarily consists of reinforced concrete columns and post-tensioned concrete beams, part of the lateral forces could be distributed through these members, as seen in Figure 9 where columns are red and beams cyan.

Two 12" thick "C" shaped walls, 31.83' long East/West and 9.58' long North/South per each "C", encase the elevator banks and are reinforced with #4 horizontally and #5 vertically. From the sixth floor down, walls running North/South are specially reinforced three feet from each end with #7 and #8 rebar. All of the shear walls use concrete with a compressive strength of  $f'_c = 6$  ksi. Building drift criteria for wind loads is  $L/400$  or  $3/8$ " inter-story drift at typical floors (12'-9" floor-to-floor) and for seismic loads is  $L/76$  or 2" inter-story drift at typical floors (12'-9" floor-to-floor).

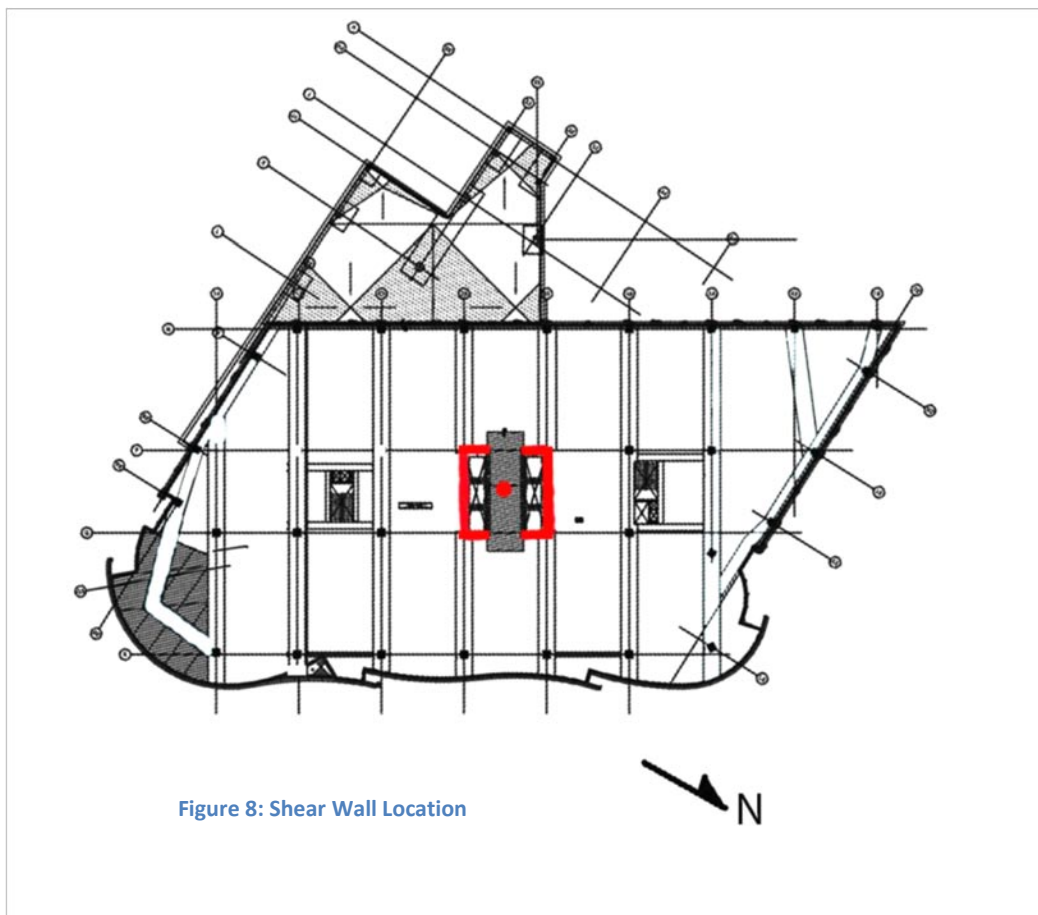

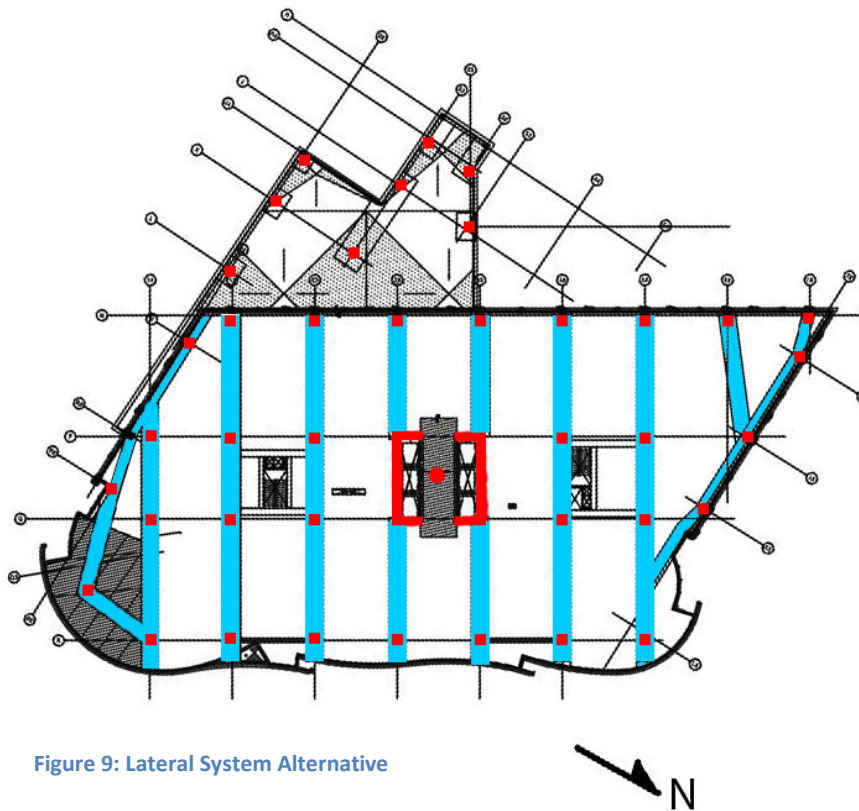

Figure 9: Lateral System Alternative

The columns throughout the building are primarily 30"x30" with 72" wide by 18" deep post-tensioned beams tying into them. Though these members were not designed to take the primary lateral force, they will transfer loads through themselves, and therefore have some affect on the lateral system. A 9" normally reinforced concrete slab transfers loads to the post-tensioned beams and act as a rigid diaphragm for the structure. Also, post-tensioned tendons surround the building slab edges to reduce slab deflection, but will also help transfer lateral forces. These are not marked above but are around the entire one-way slab perimeter.

# **Existing Structural System Analysis**

## **Deflection Criteria**

### **Horizontal Framing Deflections:**

- **Live Load**
  - $< L/600$  or  $\frac{1}{2}$ "
  
- **Total Load Excluding Self Weight**
  - $< L/480$  or  $\frac{3}{4}$ "

### **Lateral Drift:**

- **Wind Loads**
  - $< L/400$  or  $\frac{3}{8}$ "
  
- **Seismic Loads**
  - $< L/76$  or  $2$ "

### **Main Structural Elements Supporting Components and Cladding:**

- **At Screenwalls**
  - $< L/240$  or  $\frac{3}{4}$ "
  
- **At Floors Supporting Curtainwalls**
  - $< L/600$  or  $\frac{1}{2}$ "
  
- **At Roof Parapet Supporting Curtainwalls**
  - $< L/600$  or  $\frac{1}{2}$ "
  
- **At Non-Brittle Finishes**
  - $< L/240$

## Materials

### Steel:

Wide Flange	50 ksi (A992)
Plates, Channels, Angles and Bars	36 ksi (A36)
Round Pipes	42 ksi (A53 Grade B)
HSS Rectangular or Square Tubing	46 ksi (A500 Grade B)
HSS Round Tubing	42 ksi (A500 Grade B)
Bolts	36/45 ksi (A325 or A490)
Anchor Rods	(F1554 Grade 55)
Weld Strength	70 ksi (E70XX)

### Concrete:

Foundations, Int. Slab on Grade	$f'c = 3000$ psi
Interior Walls	$f'c = 5000$ psi
Ext. Slab of Grade, Pads, Garage SOG	$f'c = 4,500$ psi
Garage and Plaza Slabs, Framed Int. Slabs	$f'c = 5000$ psi
Ext. Walls, Beams, Basement Walls	$f'c = 4000$ & $5000$ psi
Deck Supported Slabs	$f'c = 3500$ psi
Cellar Columns	$f'c = 4000$ & $8000$ psi
Superstructure Columns	$f'c = 4000, 8000$ & $6000$ psi
Shear Walls	$f'c = 6000$ psi
Masonry	$f'm = 1500$ psi

### Reinforcement:

Longitudinal Bars	60 ksi (A615)
Deformed Bars (Ties)	60 ksi (A615)
Welded Wire Mesh	(A185)

### Post Tensioning:

Tendons	270 ksi (A416)
---------	----------------

### Cold Formed Steel:

20 Gage	33 ksi (A653)
18 Gage	33 ksi (A653)
16 Gage	50 ksi (A653)

Note: Material strengths are based on American Society for Testing and Materials (ASTM) standard rating.



## Design Process – Gravity System

All of the levels of the superstructure employ a one-way slab system over post-tensioned girders, colored yellow in Figure 10. Also, levels two through six have an extended area where a two-way mildly reinforced slab is implemented, colored cyan in Figure 10. Both slab analysis calculations may be referenced in prior technical report's appendices.

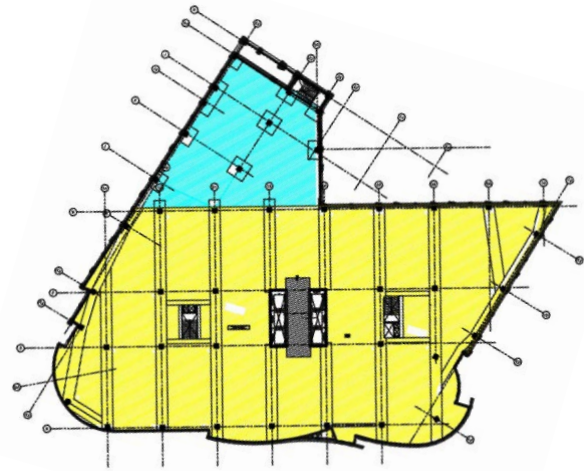

Figure 10: Slab Systems

Slab thickness is 9" with concrete compressive strength of  $f'_c = 5000$  psi. ACI 318-8, *Approximate Method of Frame Analysis*, was the design method utilized because the slab had met all of the provisions. Construction of the slab and girders was determined to be cast monolithically. Because of these findings, the strip, colored cyan in Figure 11, was analyzed as a solid slab with both ends continuous. The amount of steel reinforcement in the slab was found to be #6 @10" top reinforcing and #5 @10" bottom reinforcing.

A post-tensioned girder was examined using the simplified method of load balancing provided by Mr. Richard Apple of Holbert Apple Associates. The girder being analyzed is shaded cyan in Figure 12, which spans between 4 columns. The two outer spans, from column face to column face, are of equal length (46'-0") while the interior span is 14' shorter (30'-0"). Preliminary span-depth ratios and tendon stress were performed. More in-depth calculations of the existing gravity system may be found in the tech reports of semester one.

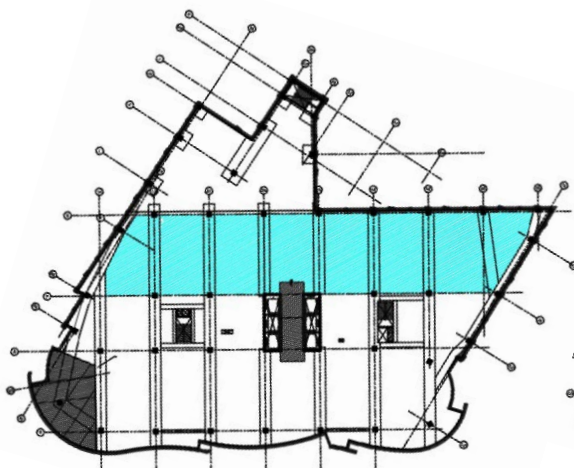

Figure 12: One-way Slab Strip

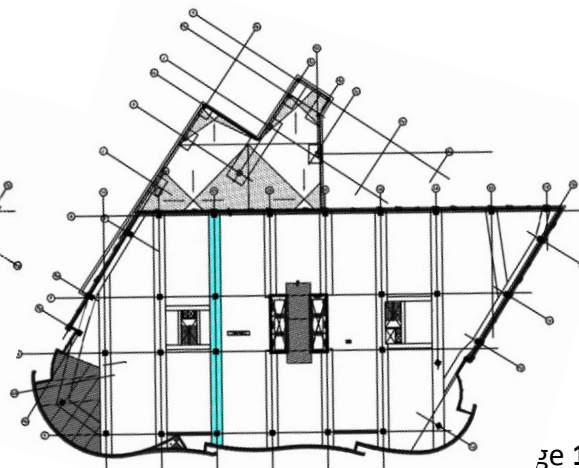

Figure 11: Post-tensioned Girder

## **Design Process – Lateral System**

Lateral analysis was performed with both wind and seismic loading in mind. Determination of which lateral loads will control the design, how the lateral loads are distributed among load resisting elements in a logical load path, and verify the lateral load resisting system have been sufficiently designed for strength and serviceability. Preliminary hand calculations were performed to investigate and determine the relative stiffness of each lateral load resisting shear wall. It was concluded that each shearwall distributed the forces uniformly in each respective direction. Shearwall relative stiffness was then used to calculate the structural center-of-rigidity (COR). Two computer models were created in ETABS to compare and verify hand calculations, one with only the shearwalls and one with the entire structure modeled. Wind and seismic loads were applied to the building and due to the nonuniform and unique smooth curved shape of 800 North Glebe, it was found that when looking at strength design, wind created greater loads. When looking at serviceability issues, seismic created greater concerns. However, thesis calculations were performed with the assumption that wind loading would play a greater role in lateral system design because of the significant surface area of the façade. This led to ASCE 7-05 load case 6 ( $0.9D + 1.6W$ ) being used for analysis.

### **Wind**

A box was drawn around the building shape, along the principle lateral system axis, as seen in Figure 13. The size of the box was approximated to enclose a majority of the building and to determine the center-of-pressure. It can be seen that the lower side of the building is perpendicular to the applied wind load. Because of this, the wind forces in this direction are larger than the wind forces acting on the left side of the building, but both faces experience significantly large wind pressures. Lateral load calculations discussed later will determine the extent of the forces increase.

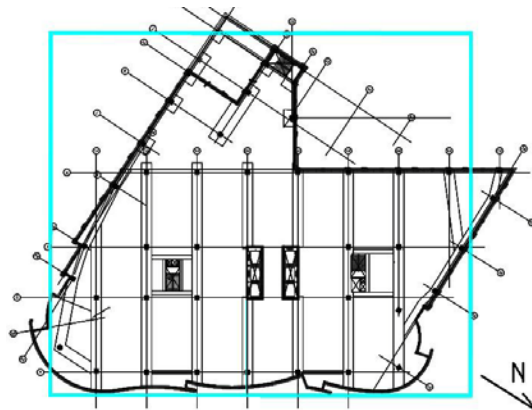

Figure 13: Initial Wind Load Determination

### Seismic

Seismic calculations of 800 North Glebe were based upon ASCE 7-05 for thesis design. The engineering firm had used ASCE 7-02 / IBC 2003 and the 2003 Virginia Uniform Statewide Building Code to calculate the base shear from the equivalent lateral force analysis procedure. Design criteria variables were used to determine story forces at each level, story shear at each level, and base shear. The model output for maximum modal period of vibration was found to be 5.6079 seconds. However, this value was not used as the fundamental period because it means the structure is more flexible than what value the code permits for fundamental period of vibration,  $T_a C_u = 1.868s$ . A lower period of vibration being used for design assumes the lateral resisting structural elements are more rigid and therefore, must be designed for the larger forces. When only the shear walls are analyzed compared to the entire structure, as seen in Figure 14 respectively, a larger period was found, meaning the structure is less stiff. The largest difference can be found in the building rotation (torsion). Since the lateral shear core is centrally located with the majority of the building spread over a large slab area causing the building to significantly rotate. The columns and beams are spread throughout the structure, increasing the stiffness and reducing the torsional effects.

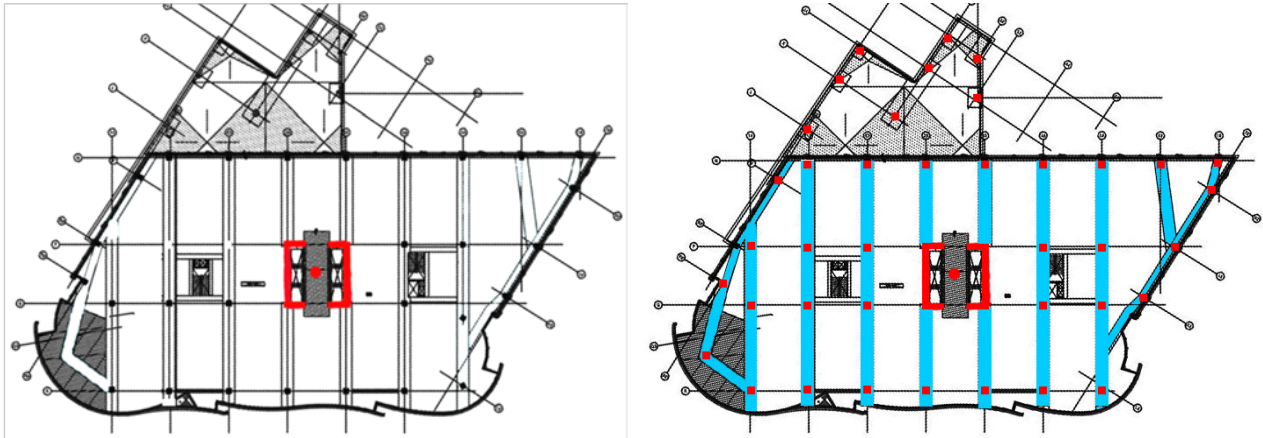

Figure 14: Shear Wall vs. Entire Structure

## **Problem Statement**

The first three technical assignments had found that current slab system and lateral structural system are capable of resisting applied loads to the building. However, because of the building shape and setbacks, two different slab systems are used throughout 800 North Glebe, where there are a total of four different slab thicknesses, using a variety of concrete strengths. Also, because of the large bay sizes, 30'x 46' typical, perimeter post-tensioned beams were added to help reduce slab edge deflections where the glass curtain wall system is attached. With this information in mind, the proposed goal is to reduce bay sizes and implement a uniform slab thickness. A new column layout required a column-beam transfer system on the first parking level to distribute loads so that the parking levels were not heavily disturbed with columns lying in the driving path.

## **Problem Solution**

Based on the analysis performed in technical report II, to allow for a uniform slab thickness with the new column grid layout, a two-way post-tensioned floor slab system would be optimal. Since post-tensioned slabs are cast-in-place, it is possible to implement the system into 800 North Glebe with its unique curved slab edges.

The increase of columns will help to reduce the building torsion, but will require transfer girders in the garage level to distribute the forces around the garage thruways and to the foundations. The current foundations will then need to be redesigned to support the new loading pattern. Along with the increased number of columns to help reduce building torsion, a post-tensioned floor slab is more rigid and therefore will contribute to the lateral load carry capacity of the structure. The original structural model, assuming only the shear walls participating in lateral load carry will be compared to a model of the entire structure participating in the lateral system.

Since part of the building is already a post-tensioned floor system, it can be deduced that the Arlington area has the proper contractors to complete the structure. Many large cities do not have experienced post-tensioned laborers, but this is not the case for Arlington. Standardizing the slabs would help to reduce the variety of concrete trades on the project.

## **Design Goals**

The overall design goal of this project is to redesign the slab system of 800 North Glebe as a two-way post-tensioned slab. This will allow for a uniform slab type and thickness throughout the superstructure and have the entire structure participate in the lateral force resisting system. Additional goals to be met throughout this project include:

- Have the entire structure participate in the lateral force resisting system and reduce the overall lateral load carried by the central core shear walls
- Reduce the impact of alterations to the architectural floor plans as laid out by the architect
- Reduce column sizes where applicable
- Not reduce the floor-to-ceiling height
- Determine affects of structural changes will have on architectural floor plans
- Compare sequencing and cost differences between systems
- Use computer programs such as RAM Concept and ETABS to perform an in-depth lateral and gravity analysis to create a more efficient structure

## **MAE Course Related Study**

To fulfill MAE requirements for senior thesis, the knowledge learned through master's level courses will be implemented. AE 538, *Earthquake Resistant Design of Buildings* was used in conjunction with information taught in AE 597A, *Computer Modeling*, to critically analyze the structural system of 800 North Glebe. Even though RAM Concept was not specifically taught, the concepts of meshing, diaphragms and property modifications will be used. Along with AE 597A, the information taught in AE 542, *Building Enclosures*, will be utilized through the determination of curtain wall systems. More information into how these courses were used in the analysis and design for thesis will be discussed throughout the report.

## **Structural Depth Study**

The structural depth study includes a design and analysis of a new gravity and lateral system for 800 North Glebe as defined in the problem statement. For this to be accomplished, all interior and exterior columns, along with the slab were designed and their integration into the lateral system was performed. Final conclusions and recommendations are based on all the impacts on the structure, which include but are not limited to; performance, architectural impact, and constructability.

## **Design Codes and Standards**

This design had been performed with the most up to date codes and standard available. These may differ from the original design, resulting in possible calculation variations.

### **Original Design:**

- International Building Code, 2003
- Virginia Uniform Building Code, 2003
- American Society of Civil Engineers (ASCE)
  - ASCE 7-02, Minimum Design Loads for Buildings and Other Structures
- American Concrete Institute (ACI)
  - Building Code Commentary 318-08
  - Structural Concrete for Buildings, ACI 301
- American Institute of Steel Construction (AISC)
  - Manual of Steel Construction, Thirteenth Edition, 2005

### **Thesis Design with Additional References:**

- International Building Code, 2006
- Virginia Uniform Building Code, 2003
- American Society of Civil Engineers (ASCE)
  - ASCE 7-05, Minimum Design Loads for Buildings and Other Structures
- American Concrete Institute (ACI)
  - Building Code Commentary 318-05
- American Institute of Steel Construction (AISC)
  - Manual of Steel Construction, Thirteenth Edition, 2005

## **Material Properties**

### **Steel:**

Wide Flange	50 ksi (A992)
Plates, Channels, Angles and Bars	36 ksi (A36)
Round Pipes	42 ksi (A53 Grade B)
HSS Rectangular or Square Tubing	46 ksi (A500 Grade B)
HSS Round Tubing	42 ksi (A500 Grade B)
Bolts	36/45 ksi (A325 or A490)
Anchor Rods	(F1554 Grade 55)
Weld Strength	70 ksi (E70XX)

### **Concrete:**

Foundations, Int. Slab on Grade	$f'c = 3000$ psi
Interior Walls	$f'c = 6000$ psi
Ext. Slab of Grade, Pads, Garage SOG	$f'c = 4500$ psi
Garage and Plaza Slabs, Framed Int. Slabs	$f'c = 8000$ psi
Ext. Walls, Beams, Basement Walls	$f'c = 4000$ & $5000$ psi
Deck Supported Slabs	$f'c = 3500$ psi
Cellar Columns	$f'c = 4000$ & $8000$ psi
Superstructure Columns	$f'c = 4000, 6000$ & $8000$ psi
Shear Walls	$f'c = 6000$ psi
Masonry	$f'm = 1500$ psi

### **Reinforcement:**

Longitudinal Bars	60 ksi (A615)
Deformed Bars (Ties)	60 ksi (A615)
Welded Wire Mesh	(A185)

### **Post Tensioning:**

Tendons	270 ksi (A416)
---------	----------------

### **Cold Formed Steel:**

20 Gage	33 ksi (A653)
18 Gage	33 ksi (A653)
16 Gage	50 ksi (A653)

**Note: Material strengths are based on American Society for Testing and Materials (ASTM) standard rating.**

## Slab Design

### Design Loads

#### **Gravity - Live Loads**

ASCE 7-05, *Minimum Design Loads for Buildings and other Structures*, was the main reference for determination of loads in this project for 800 North Glebe. These loads were compared to the loads specified by the designer per IBC 2003 and the 2003 Virginia Uniform State Building Code which references ASCE 7-02. A few loadings used by the designer were seen to be greater, i.e. garage entry, and therefore the larger value was used for thesis because of the significant increase. These values are outlined in Table 1 below.

Live Loads				
Description	Location	Designer Loads	(ASCE 7-05)	Thesis Loads
Parking	P3	40	40	40
Stairs	P3	100	100	100
Parking	P2	40	40	40
Stairs	P2	100	100	100
Parking	P1	40	40	40
Stairs	P1	100	100	100
Garage Entry	Level 1	250	50	250
Main Retail/Assembly	Level 1	100 125 250	100	100
Elevator Lobby	Level 1	100	100	100
Entry	Level 1	100	100	100
Loading Dock	Level 1	350		350
Yards and Terraces	Level 1	100	100	100
Marquees and Canopies	Level 2	75	75	75
Corridors Above First Floor	Level 2-10	100	80	80
Walkways and Elevated Platforms		60	60	60
Mechanical	Penthouse	150	125	125
Roof	Roof	30	20	20

Table 1: Live Loads



**Gravity - Dead Loads**

Building dead loads and their general description are laid out in Table 2 below. Slab areas were taken from CAD floor plans provided by the designer and varied by floor because of the curves and the major setback at levels four, six and eight. For the original design, slab thicknesses of 7 ½”, 9”, 10 ½” and 12” are used per floor depending on the location and area usage. Two-way mildly reinforced slabs located on levels two through six have slab thicknesses of 10 ½” with 7” thick drop panels to reduce the punching shear around the columns. Across the post-tensioned girders is the 9” one-way slab. Located at the main entrance is a 36” diameter column rising from the ground to the top of the building with a 12” cantilevered slab. The 12” slab was needed because of the increased moment the cantilevered section caused over the beam. However, the thesis design implemented a uniform 8” two-way slab with 4” shear caps around the columns for all elevated slabs.

Dead Loads				
Description	Location	Designer	Superimposed Dead Load	Thesis Loads
Concrete	All Levels	150 pcf		150 pcf
Partitions, Finishes	All Levels		20 psf	20 psf
MEP	All Levels		5 psf	5 psf
Precast Panels	Curtain Wall		35 psf	20 psf*
Curtain Glass	Curtain Wall		15 psf	

\*Assume the façade is composed of 20% precast and 80% glazing.

Table 2: Dead loads

**Design Process – Initial Layout**

To allow for the implementation of a two-way slab system, the column layout needed to be redesigned. Bay sizes were reduced from 46’-0” X 30’-0” down to 30’-0” X 23’-0” to allow for a uniform slab type and thickness, as seen in Figures 15 and 16 respectively. Other systems were capable of being implemented onto the new column layout, which include steel frame system, but to avoid floor-to-ceiling height reduction the two-way concrete slab was the preferred system. Design issues that were of concern include: which direction for banded tendons, how to deal with openings, and use of shear caps for punching shear.



Figure 15: Current Column Layout

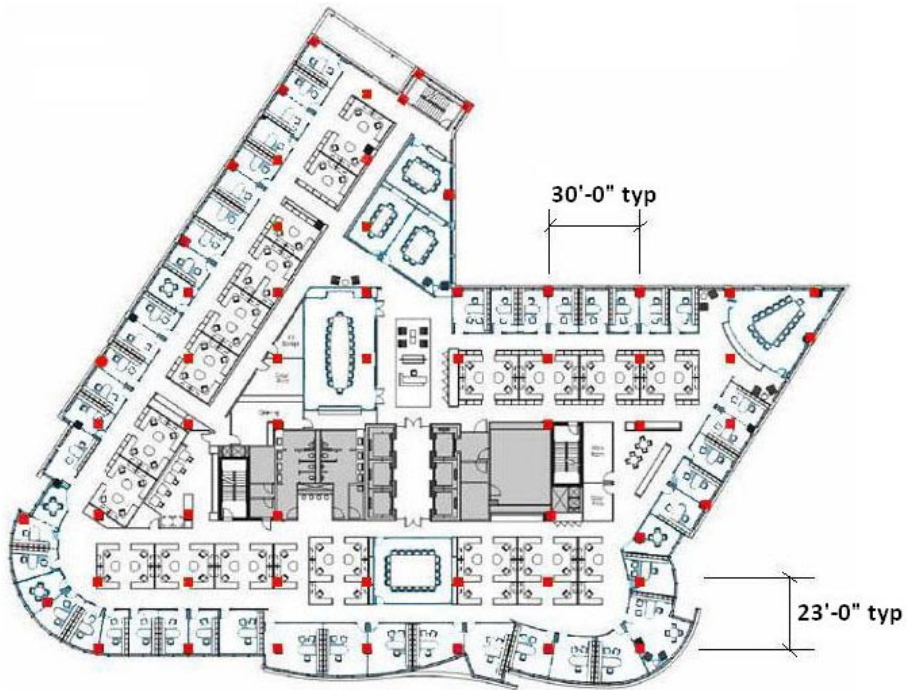

Figure 16: New Column Layout

An initial slab thickness of 8" was calculated based on the span-to-depth ratio of *Holbert Apple Associates' Post-Tensioned Concrete Practical Applications*". Shear capitals were needed at all column locations to reduce shear failure and allow for increased slab-to-column reinforcing. Descriptions of these are discussed in the analysis and detailing section. Uniformly distributed tendons span the 30'-0" long direction while bonded tendons would span the shorter 23'-0" direction. Shortening concerns were addressed to avoid negative shear wall affect. However, since the shear wall core was centrally located, which is the preferred method to avoid shortening problems; this was presumed to not be an issue.

### **Design Process – Computer Model**

*RAM Concept* models were created for the two primary slab layouts; the lower six levels and the upper four levels. This program was chosen because of the finite element analysis capabilities for a two-way post-tensioned slab system. An initial slab strip was modeled in Ram Concept's *Slab Wizard* to determine the initial amount of tendons needed to balance 70% of the construction dead load and their respective profile depth at ends and midpoints. Hand calculations were performed to determine the initial effective stress, but the percent difference between those values was around 35%. It was concluded that this was far too large for hand calculations to be a viable design method. Once an initial tendon scheme was calculated, the layout was implemented over the entire slab. Due to slab nonuniformities, such as openings, overhangs and nonprismatic slab edges, tendons were altered to meet ACI precompression minimums of 250psi accordingly. However, for two-way slab design, the typical precompression is 150psi-250psi, and up to 300psi in end spans.

Uniformly distributed tendons have four strands per tendon. Spacing of these tendons was based on ACI 318-08, section 18.12.4, where spacing shall provided a minimum average effective prestressing force of 125 psi. Where slab opening less than 4'-0" in width are located, the tendons swept around each side, but where openings were larger, the tendons were anchored off and resumed on the opposite side. The profile depths at the ends are 1" below the top of slab, while profile depths at the midspan are 5.6" below. The distributed on tendons in the north-south direction is laid out in Figures 17 and 18.

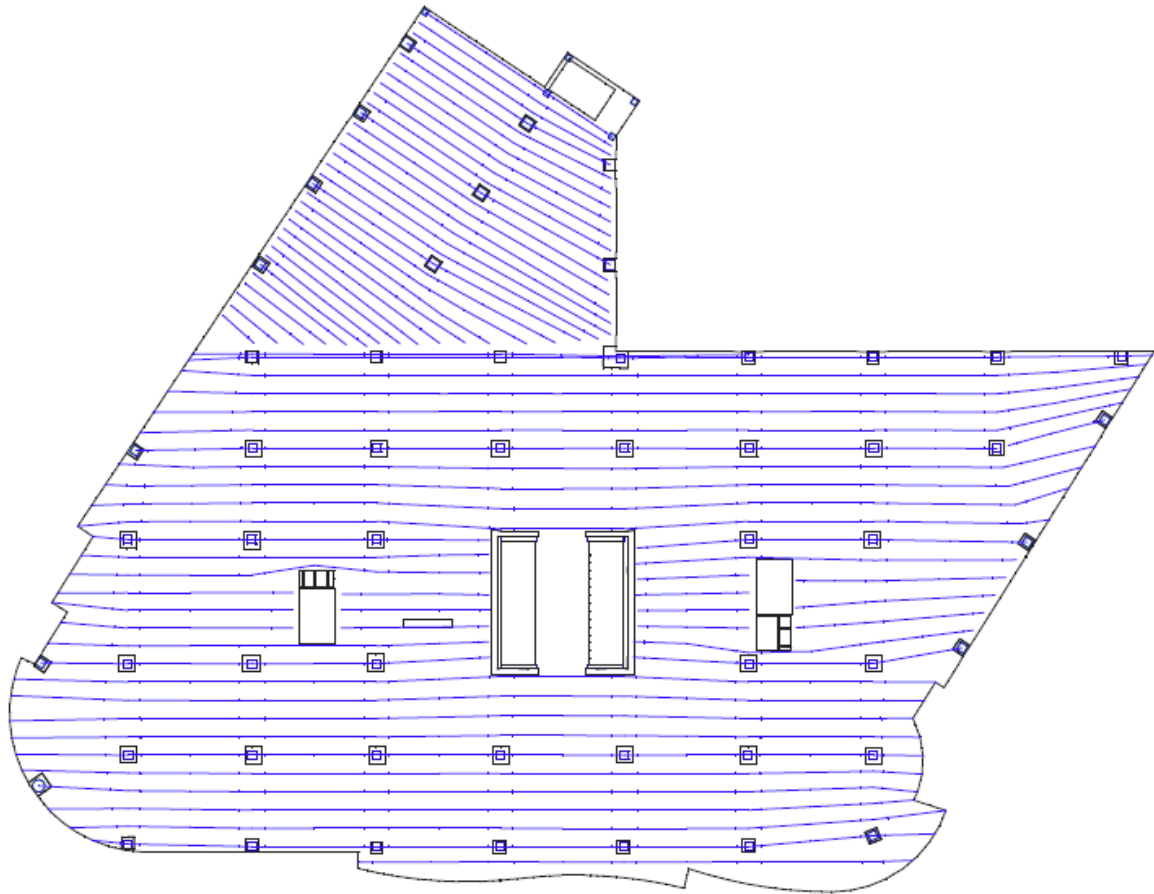

Figure 17: Lower 6 Levels Distributed Tendon Layout

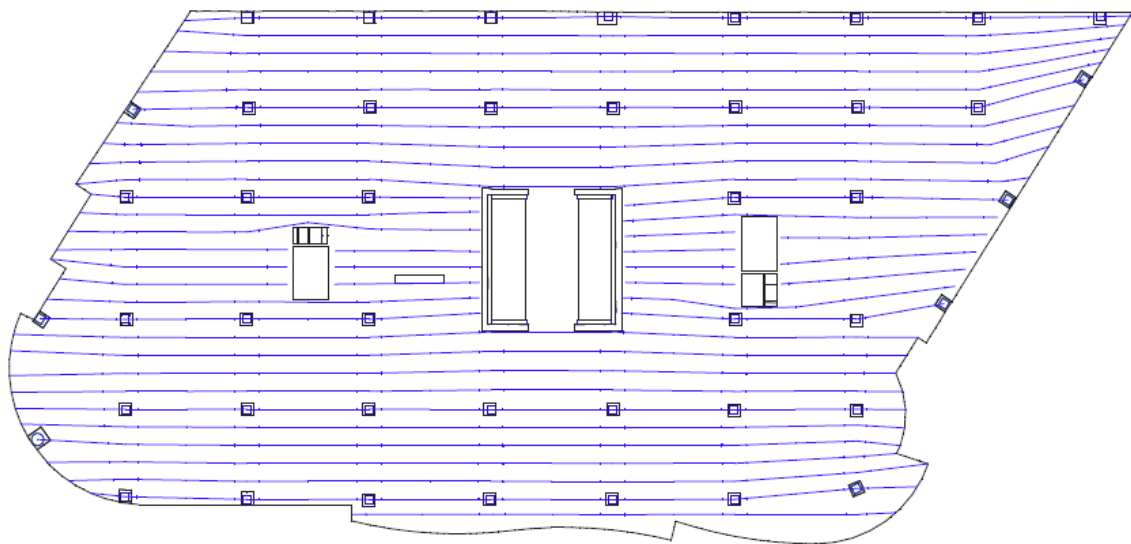

Figure 18: Upper 4 Levels Distributed Tendon Layout

Tendons banded along the short direction were grouped in the columns strip, as seen in Figures 19 and 20. This allowed for tendon forces of 650kips, on average. The banded tendon profiles in this direction were designed with the same depth as the uniformly distributed tendon layout. These banded tendon regions act as beams in the lateral system concrete moment frames.

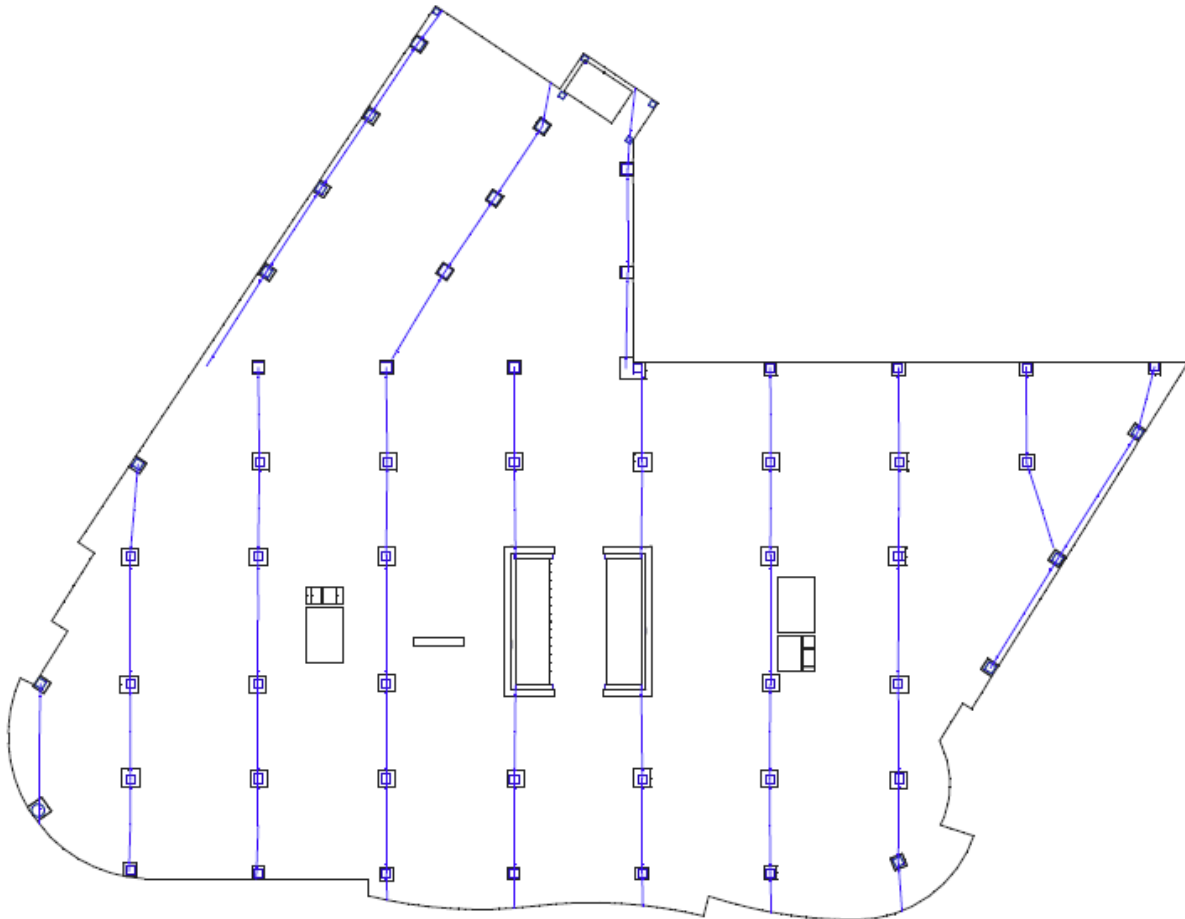

Figure 19: Lower 6 Levels Banded Tendon Layout

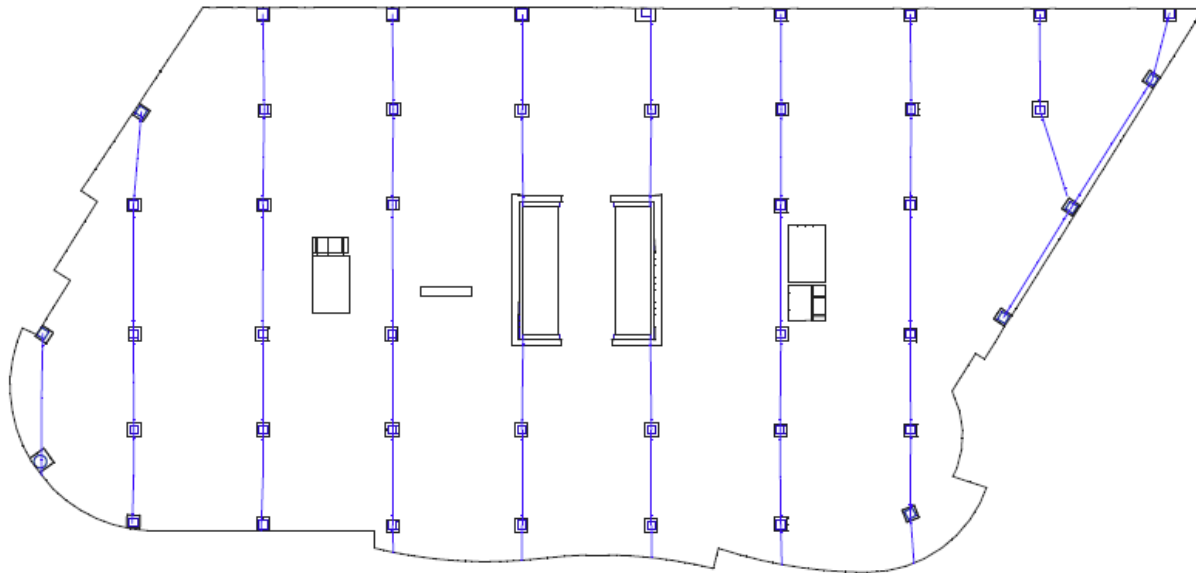

Figure 20: Upper 4 Levels Banded Tendon Layout

### **Design Process – Analysis and Detailing**

Strength checks were performed on the initial tendon layout. Analysis verification was based on chapter 18 and Appendix B of ACI 318-05, and a detailed list of sections used is available in Appendix C. Design included the most significant load case from ASCE 7-05. Factored moments and shear were to meet the Equivalent Frame method of ACI section 13.7, but it was permitted to use a more detailed method including elastic theory, which I determined to be a RAM Concept model.

Although this flat plate system was used in the lateral force resisting system (LFRS), the column strip area was analyzed with section 18.2: Slab System, and not by section 18.7: Flexural Members. Classification of the two-way slab met criteria for Class-U design, in which stresses at service are permitted to be performed with uncracked sections, along with  $f_t \leq 7.5 \sqrt{f'_c}$ . Slab concrete strength was designed with 8,000 psi concrete. This allowed for a maximum precompression tensile zone extreme fiber stress at service conditions to be 671 psi. The steel tendons permissible tensile stresses were designed not to exceed  $0.7 * f_{pu}$ , where  $f_{pu}$  was taken to be 26, 000 ksi.

Anchoring and stressing the tendons will be done in sections due to constructability restrictions. The spans are so great that tendons will need to be done in stages. Anchorage zones are composed of two sections; the local and general zone, as seen in Figure 21. Both

local and general zone design is based upon factored prestressing force  $P_{pu}$ , and is strongly influenced by the specific characteristics of the anchorage device and its respective reinforcing. Reinforcing for the local zone is done to allow for proper function of the anchoring device. General zone reinforcing is designed to resist bursting, spalling and longitudinal edge tension forces.

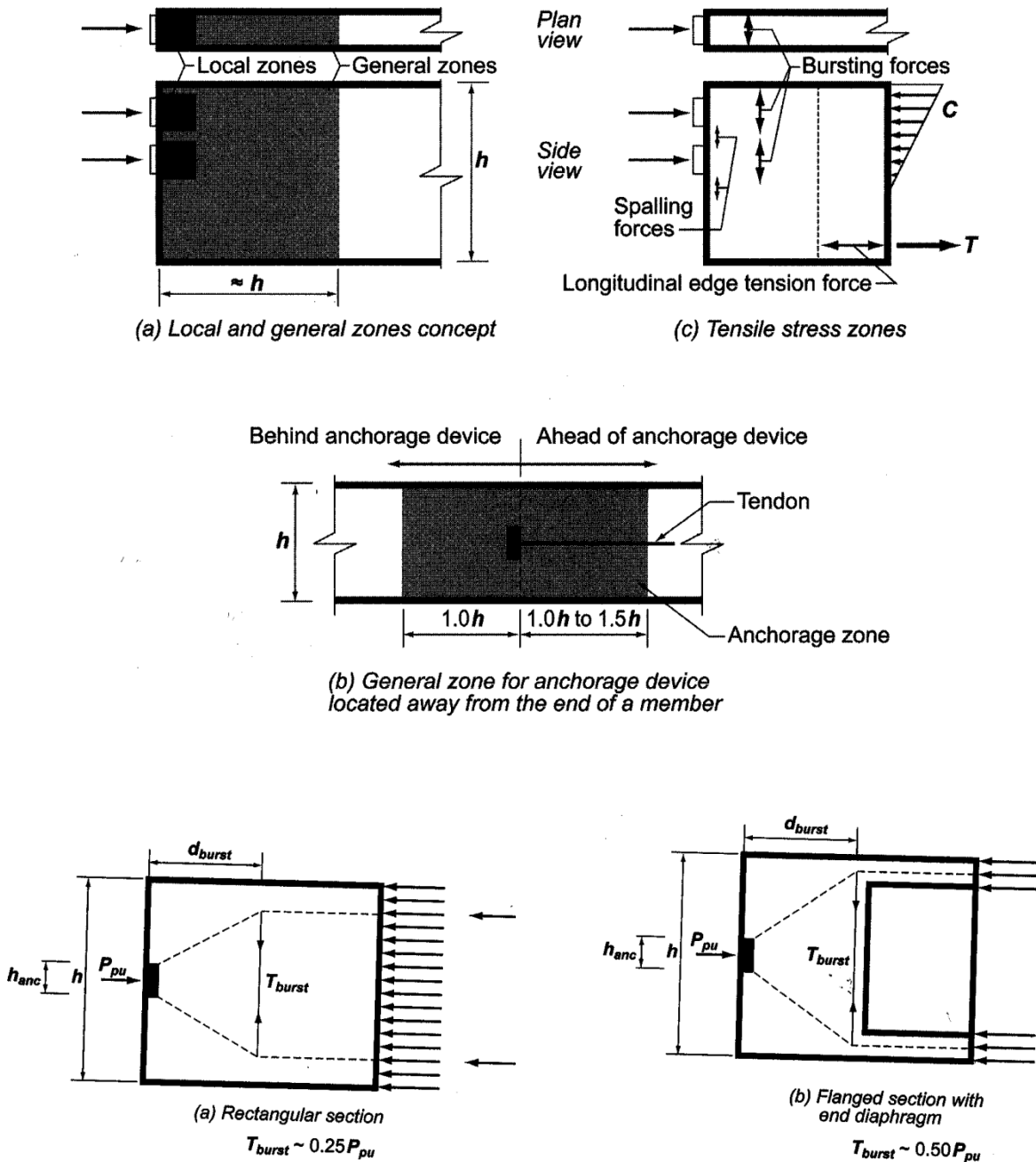

Figure 21: Anchorage Zones

Determination of anchorage specifics are primarily done at the shop drawing stage of design with test information from the manufacturer. Therefore, since the reinforcing and design of this region is heavily influenced by the anchored selection, explicit requirements for reinforcing cannot be completed until specific devices are chosen and are not in the scope of this thesis. Schematic layouts of reinforcing can be seen in Figure 22 below.

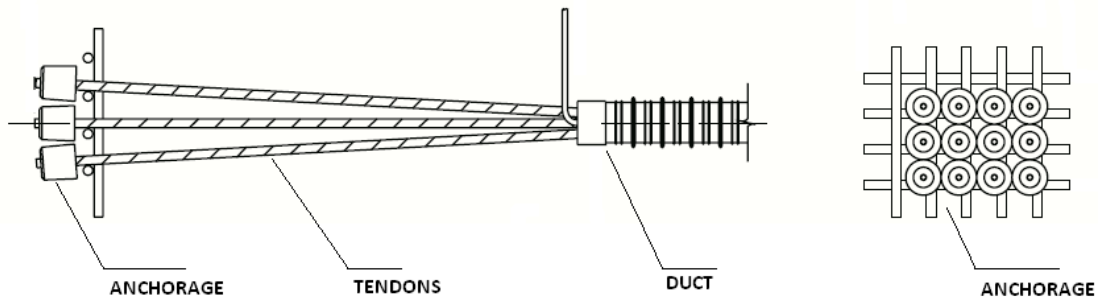

Figure 22: Anchorage Zone Plan and Elevation View

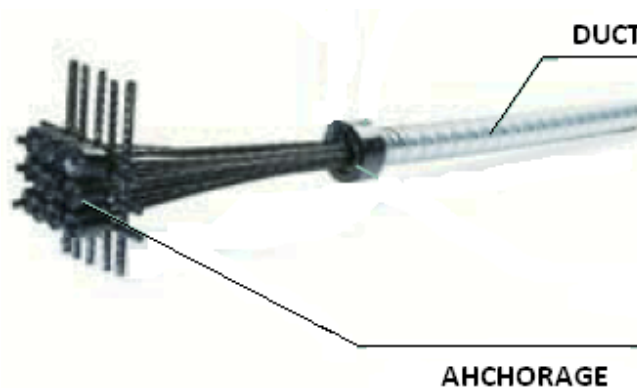

Figure 23: Actual Anchorage Image

A slab system without beams has major punching shear concerns around the columns. ACI states “slabs with unbounded tendons, a minimum of two ½” diameter, seven-wire post-tensioned strands shall be provided in each direction at columns, either passing through or anchored within the region bounded by the longitudinal reinforcement of the columns.” These two tendons must pass under orthogonal tendons in adjacent spans to aid in suspending the span following a punching shear failure. The aforementioned requirement for uniformly distributed tendons in one direction and banded tendons in the other can be satisfied by first placing the banded tendons and then placing the distributed tendons. However, since the slab system is also part of the LFRS, positive and negative moment may be induced at slab-column



connects and increased reinforcing in these areas. The increased concrete area around the slab-column interface allowed for more reinforcement space. A detail of the tendon layout around a column can be seen in Figure 24 below.

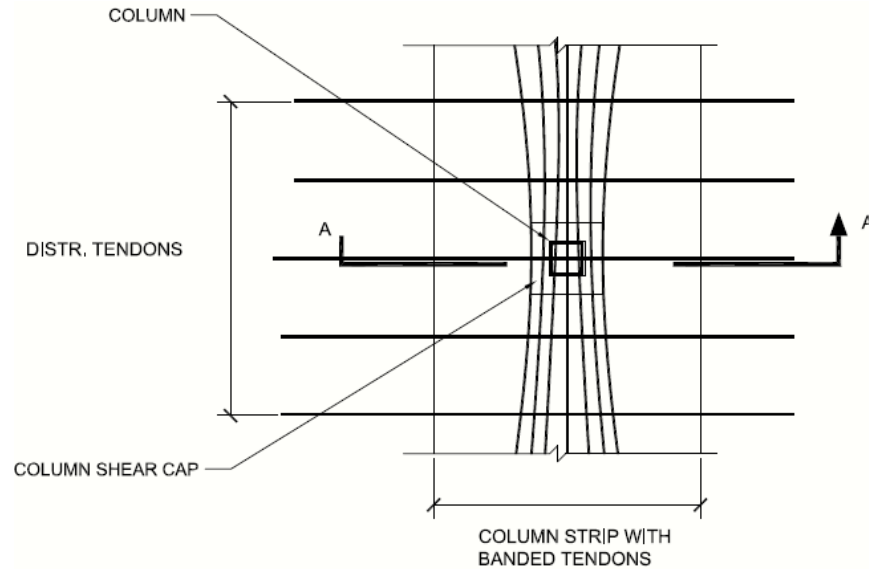

Figure 24: Tendon Layout Plan Around Column

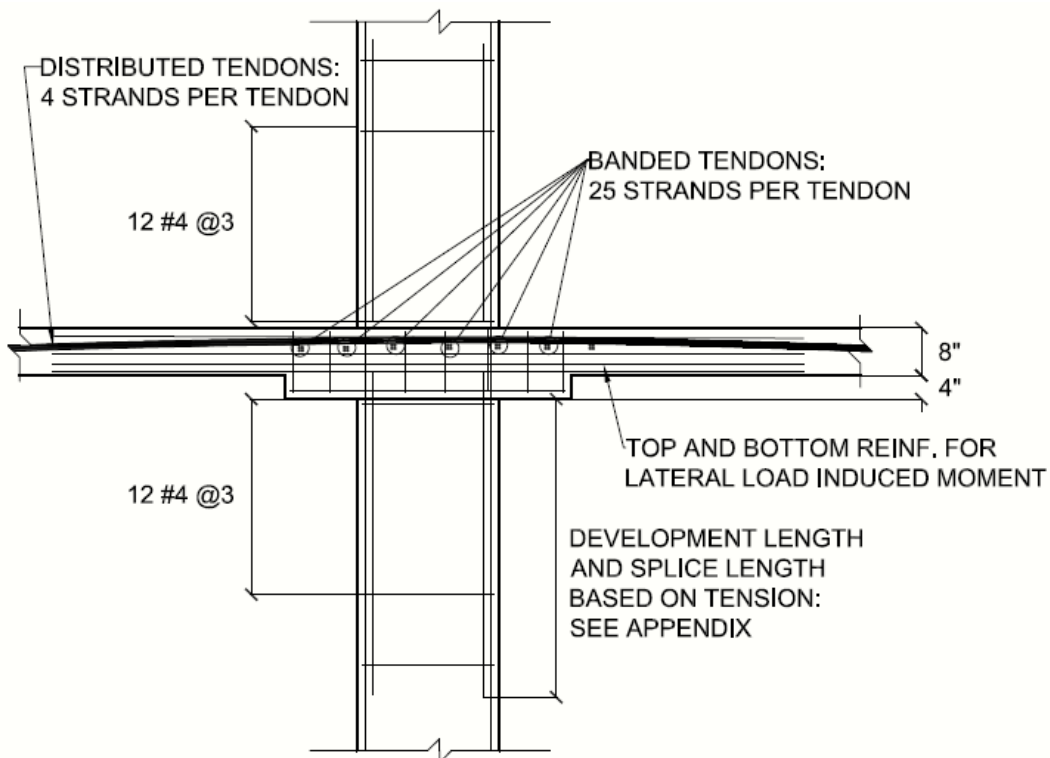

Figure 25: Section A-A

Two-way slabs deflection determination dealt with deflection in both directions in an additive process, where Figure 26 shows how a bay of a two-way slab deflects. Slab deflection calculations were based on live load criteria.

- Service LC – (Dead Load + Balanced Load) = Immediate Load Deflection
- Long Term LC – (Dead Load + Balanced Load) = Time Dependent Deflection

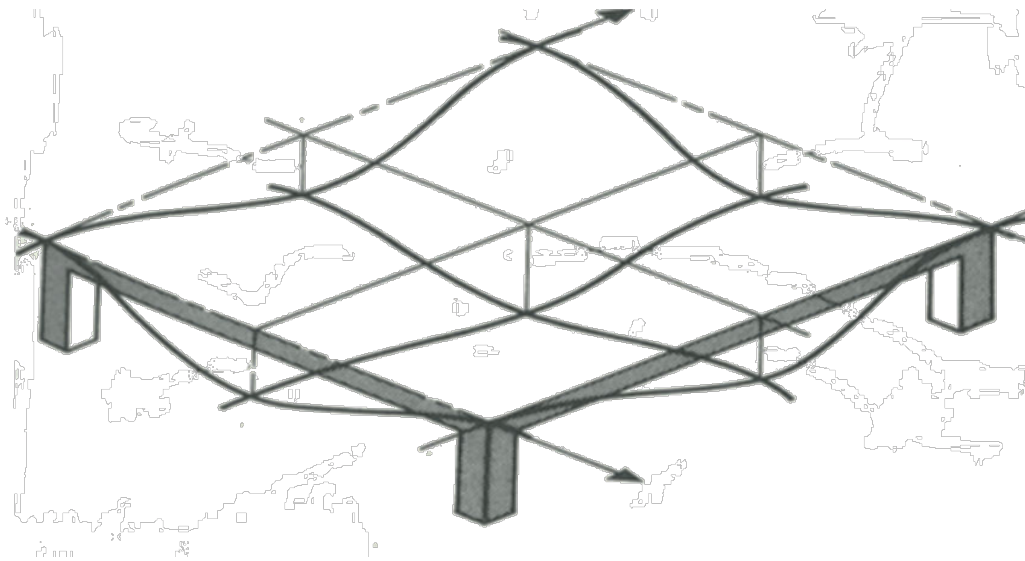

Figure 26: Two-way Slab Deflection

Deflection values were taken from RAM Concept and compared to the values of a two-way slab deflection calculation performed by hand. Figure 27 displays a contour deflection plan of the entire third floor slab and depicts what areas were concerned with deflection verification.

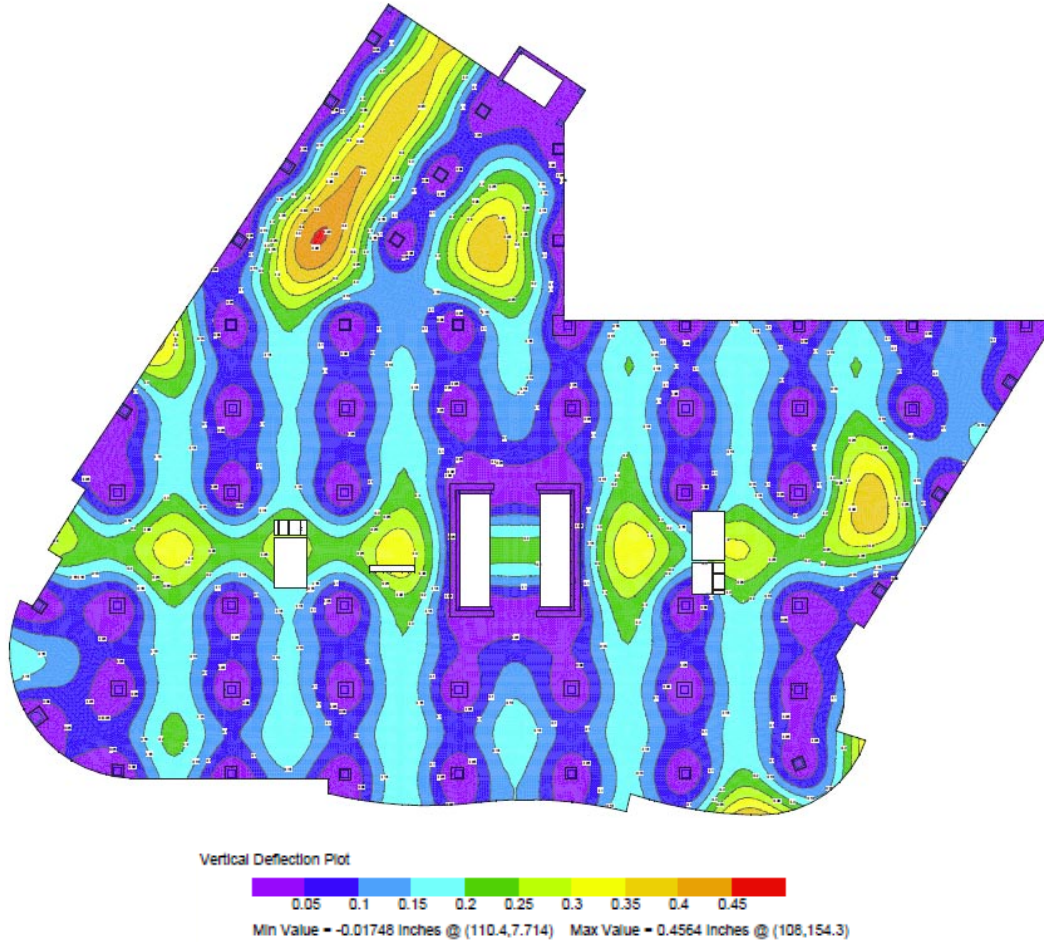

Figure 27: Lower Level Deflection Contour Plan

Based on ACI 318-08 section 18.3.5, immediate live load deflection shall not exceed  $\frac{l}{360}$  and shall not exceed  $\frac{l}{240}$  for time-deflection characteristics. Time related deflections concerns itself with creep, shrinkage and loss of tension in the tendons over time. As seen in Table 3, the deflection criteria of the slab are adequately reinforced to meet code.

Deflection					
	Code Maximum	Hand Calculation		RAM Concept	
Live Load	0.74"	0.362"	MEETS CODE	0.31"	MEETS CODE
Time Related	1.1"	NA	NA	1.06"	MEETS CODE

Table 3: Deflection Verification

## Lateral System Optimization Design

### Load Combinations

AISC 7-05 section 2.3, strength design load combinations were considered for factoring gravity and lateral loads in analysis. When only gravity load cases are considered, load case 2 usually governs. However, when lateral loads are involved in analysis, load cases 4, 5, 6 or 7 may govern depending on lateral load magnitudes and whether overturning is addressed. The load combinations considered for thesis analysis are listed below. For the thesis building being analyzed, these combinations were entered into an ETABS model.

1.  $1.4(D+F)$
2.  $1.2(D+F+T) + 1.6(L+H) + 0.5(L_r \text{ or } S \text{ or } R)$
3.  $1.2D + 1.6(L_r \text{ or } S \text{ or } R) + (L \text{ or } 0.8W)$
4.  $1.2D + 1.6W + L + 0.5(L_r \text{ or } S \text{ or } R)$
5.  $1.2D + 1.0E + L + 0.2S$
6.  $0.9D + 1.6W + 1.6H$
7.  $0.9D + 1.0E + 1.6H$

Once the controlling wind and earthquake cases were found, it was determined by shears at the base level, the load cases including 1.6W were larger in the north-south (X) direction and the east-west (Y) direction, which can be seen in Table 4 below. This is primarily due to the large surface areas of the façade, which produce larger wind pressures, and therefore larger story forces on the structure. The wind loads in east-west directions had a much more significant increase compared to the north-south direction.

X-Direction Section Cut @ Base Level		Y-Direction Section Cut @ Base Level	
Load combination	Direct Shear force	Load combination	Direct Shear force
Wind: Combinations 4 and 6	<b>848.87</b>	Wind: Combinations 4 and 6	<b>964.67</b>
Earthquake: Combination 5 and 7	722.2	Earthquake: Combination 5 and 7	868.2

Table 4: Load Combination Check

**Design Loads**

**Wind Loads**

ASCE 7-05 was the governing resource for wind load calculations. Section 6.5 describes *Method 2 – Analytical Procedure* for main wind-force resisting systems (MWRS) of enclosed buildings. Exposure, height, topographic effects, wind direction and wind velocity all played a part in determining velocity pressures. In conjunction with gust effect factors, external and internal pressure coefficients, and force coefficients it was eventually determine the base shear for the building. Section four outlines four cases in which wind loads should be applied to determine the greatest story forces. These cases were entered into a computer model and it was found that case one, full wind loads applied to the primary axis without eccentricity effects, produced the greatest forces on the structure. Table 5 details the values of all wind cases used in determination and visual representations of the cases are in Figure XX.

X-Direction Wind Case Determination			Y-Direction Wind Case Determination		
Wind Case	X-Force	Y-Force	Wind Case	Y-Force	X-Force
Case 1	<b>-848.87</b>	0.77	Case 1	<b>-964.67</b>	0.96
Case 2: Positive Pressure and Torsion	-641.12	8.05	Case 2: Positive Pressure and Torsion	-712.97	-5.59
Case 2: Negative Pressure and Torsion	-632.1	-6.91	Case 2: Negative Pressure and Torsion	-734.05	7.1
Case 3: Positive X Pressure, Positive Y Pressure	-636.01	-722.9	Case 3: Positive X Pressure, Positive Y Pressure	-722.9	-636.01
Case 3: Positive X Pressure, Negative Y Pressure	-637.22	724.04	Case 3: Positive X Pressure, Negative Y Pressure	724.04	-637.22
Case 4: Postive X Pressure and Torsion, Postive Y Pressure and Torsion	-485.11	-528.67	Case 4: Postive X Pressure and Torsion, Postive Y Pressure and Torsion	-528.67	-485.11
Case 4: Postive X Pressure and Negative Torsion, Postive Y Pressure and Torsion	-486.02	556.53	Case 4: Postive X Pressure and Negative Torsion, Postive Y Pressure and Torsion	556.53	-486.02
Case 4: Postive X Pressure and Torsion, Postive Y Pressure and Negative Torsion	-475.59	-544.48	Case 4: Postive X Pressure and Torsion, Postive Y Pressure and Negative Torsion	-544.48	-475.59
Case 4: Postive X Pressure and Torsion, Negative Y Pressure and Postive Torsion	-478.34	-539.89	Case 4: Postive X Pressure and Torsion, Negative Y Pressure and Postive Torsion	-539.89	-478.34
Case 4: Negative X Pressure and Postive Torsion, Postive Y Pressure and Torsion	470.03	-529.59	Case 4: Negative X Pressure and Postive Torsion, Postive Y Pressure and Torsion	-529.59	470.03

Table 5: Wind Case Determination

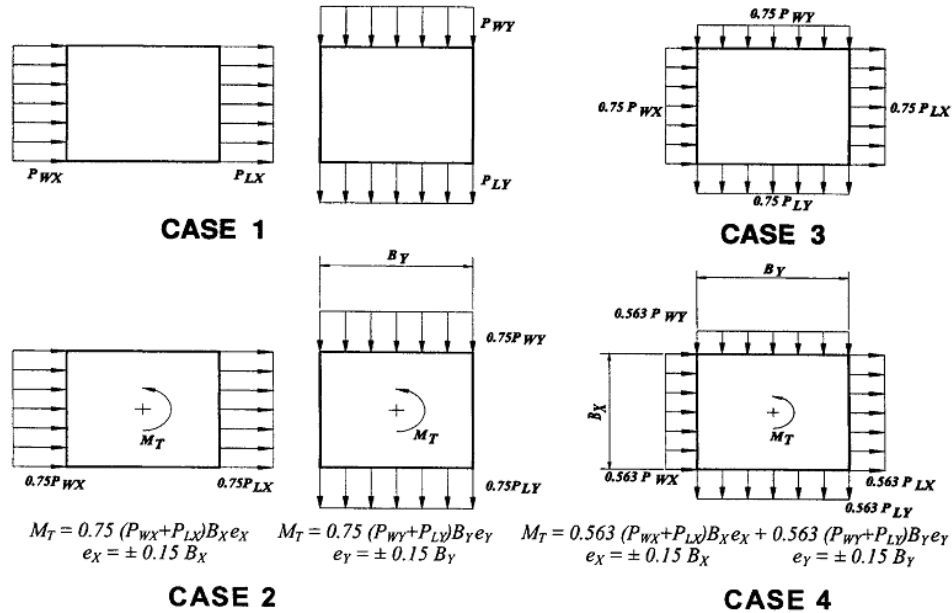

- Case 1.** Full design wind pressure acting on the projected area perpendicular to each principal axis of the structure, considered separately along each principal axis.
- Case 2.** Three quarters of the design wind pressure acting on the projected area perpendicular to each principal axis of the structure in conjunction with a torsional moment as shown, considered separately for each principal axis.
- Case 3.** Wind loading as defined in Case 1, but considered to act simultaneously at 75% of the specified value.
- Case 4.** Wind loading as defined in Case 2, but considered to act simultaneously at 75% of the specified value.

Figure 28: Wind Case Visual Representation

Variables used in analysis are outline in Table 6 below, and the calculations are shown in Appendix E. Tables 7 shows how the forces act on the building in the north-south (X) direction while Figure 29 depicts how the forces act on the structure. The figures and tables are based on the MWRS calculations and are the forces used in the computer model.

Table 8 shows the forces acting in the east-west (Y) Directions, and Figures 30 depiction how these pressures act on the building at each level. Values in the east-west direction were found to be greater than those in the north-south direction.

Wind Loads			
Category			Reference
Basic Wind Speed (mph)	$V_{3s}$	90	Figure 6-1
Importance Factor	I	1.0	Table 6-1
Exposure Category	-	B	6.5.6.3
Directionality Factor	$K_d$	0.85	Table 6-4
Topographic Factor	$K_{zt}$	1.00	6.5.7.1
Intensity of Turbulance	$I_z$	Varies	Eq. 6-5
Integral Length Scale of Turbulence	$L_z$	Varies	Eq. 6-7
Background Response Factor (North/South)	Q	0.780	Eq. 6-6
Background Response Factor (East/West)	Q	0.778	Eq. 6-6
Gust Effect Factor (N/S)	$G_f$	0.8191	6.5.8.1
Gust Effect Factor (E/W)	$G_f$	0.8175	6.5.8.1
	$GC_{pi}$	0.18	Figure 6-5
	$GC_{pi}$	-0.18	Figure 6-5
Windward Pressure	$C_p$	0.8	Figure 6-6
Leeward Pressure (E/W)	$C_p$	-0.5	Figure 6-6
Leeward Pressure (N/S)	$C_p$	-0.45	Figure 6-6 (interpolated)
Velocity Pressure Exposure Coefficient Evaluated at Height z	$K_z$	Varies	Table 6-3
Velocity Pressure at Height z	$q_z$	Varies	Eq. 6-15
Velocity Pressure at Mean Roof Height	$q_h$	19.70	Eq. 6-15

Table 6: Wind Load Variables

Wind Loads N/S (Short Walls Resisting)								
Floor	Story Height (ft)	Height Above Ground (ft)	K <sub>z</sub>	q <sub>z</sub>	Wind Pressure (psf)		Force of Windward Pressure (k)	Story Shear Windward (k)
					Windward	Leeward		
PH Roof	0	153.75	1.12	19.70	12.91	-7.26	24.75	0.00
PH	18.5	135.25	1.08	18.99	12.44	-7.26	42.58	24.75
10	13.75	121.5	1.04	18.41	12.07	-7.26	35.07	67.33
9	13.75	107.75	1.01	17.79	11.66	-7.26	32.65	102.40
8	12.75	95	0.97	17.16	11.25	-7.26	30.21	135.05
7	12.75	82.25	0.93	16.47	10.79	-7.26	28.89	165.26
6	12.75	69.5	0.89	15.70	10.29	-7.26	27.41	194.16
5	12.75	56.75	0.84	14.82	9.71	-7.26	25.68	221.56
4	12.75	44	0.78	13.78	9.03	-7.26	23.59	247.24
3	12.75	31.25	0.71	12.49	8.19	-7.26	20.88	270.84
2	12.75	18.5	0.61	10.76	7.05	-7.26	9.66	291.72
1	18.5	0	0.00	0.00	0.00	0.00	0.00	301.38
<b>Σ Factored Windward Story Shear (k)=</b>								<b>482.21</b>
<b>Σ Factored Windward Overturning Moment (ft-k)=</b>								<b>44515</b>

Wind Loads N/S (Short Walls Resisting)					
Floor	Story Height (ft)	Height Above Ground (ft)	Total Pressure (psf)	Force of Total Pressure (k)	Story Shear Total (k)
PH Roof	0	153.75	20.17	39.18	0.00
PH	18.5	135.25	19.70	67.75	39.18
10	13.75	121.5	19.33	56.53	106.94
9	13.75	107.75	18.92	53.33	163.47
8	12.75	95	18.51	50.11	216.80
7	12.75	82.25	18.05	48.80	266.92
6	12.75	69.5	17.55	47.31	315.71
5	12.75	56.75	16.97	45.58	363.02
4	12.75	44	16.29	43.50	408.60
3	12.75	31.25	15.45	40.78	452.10
2	12.75	18.5	14.31	19.61	492.88
1	18.5	0	0.00	0.00	512.49
<b>Σ Factored Windward Story Shear (k)=</b>					<b>819.99</b>
<b>Σ Factored Windward Overturning Moment (ft-k)=</b>					<b>73606</b>

Table 7: North-South Wind Load Forces



Wind Loads E/W (Long Walls/Frame Resisting)								
Floor	Story Height (ft)	Height Above Ground (ft)	K <sub>z</sub>	q <sub>z</sub>	Wind Pressure (psf)		Force of Windward Pressure (k)	Story Shear Windward (k)
					Windward	Leeward		
PH Roof	0	153.75	1.12	19.70	12.88	-8.05	28.72	0.00
PH	18.5	135.25	1.08	18.99	12.42	-8.05	49.41	28.72
10	13.75	121.5	1.04	18.41	12.04	-8.05	40.70	78.13
9	13.75	107.75	1.01	17.79	11.64	-8.05	37.89	118.83
8	12.75	95	0.97	17.16	11.23	-8.05	35.06	156.72
7	12.75	82.25	0.93	16.47	10.77	-8.05	33.53	191.78
6	12.75	69.5	0.89	15.70	10.27	-8.05	31.80	225.31
5	12.75	56.75	0.84	14.82	9.69	-8.05	29.80	257.12
4	12.75	44	0.78	13.78	9.01	-8.05	27.38	286.92
3	12.75	31.25	0.71	12.49	8.17	-8.05	24.23	314.30
2	12.75	18.5	0.61	10.76	7.03	-8.05	11.21	338.53
1	18.5	0	0.00	0.00	0.00	0.00	0.00	349.74
<b>Σ Factored Windward Story Shear (k)=</b>								559.58
<b>Σ Factored Windward Overturning Moment (ft-k)=</b>								51657

Wind Loads E/W (Long Walls/Frame Resisting)					
Floor	Story Height (ft)	Height Above Ground (ft)	Total Pressure (psf)	Force of Total Pressure (k)	Story Shear Total (k)
PH Roof	0	153.75	20.93	47.33	0.00
PH	18.5	135.25	20.47	81.87	47.33
10	13.75	121.5	20.09	68.37	129.20
9	13.75	107.75	19.69	64.56	197.57
8	12.75	95	19.28	60.72	262.13
7	12.75	82.25	18.82	59.19	322.85
6	12.75	69.5	18.32	57.46	382.05
5	12.75	56.75	17.74	55.46	439.51
4	12.75	44	17.06	53.04	494.97
3	12.75	31.25	16.22	49.89	548.01
2	12.75	18.5	15.08	24.04	597.91
1	18.5	0	0.00	0.00	621.95
<b>Σ Factored Windward Story Shear (k)=</b>					995.12
<b>Σ Factored Windward Overturning Moment (ft-k)=</b>					89167

Table 8: East-West Wind Load forces

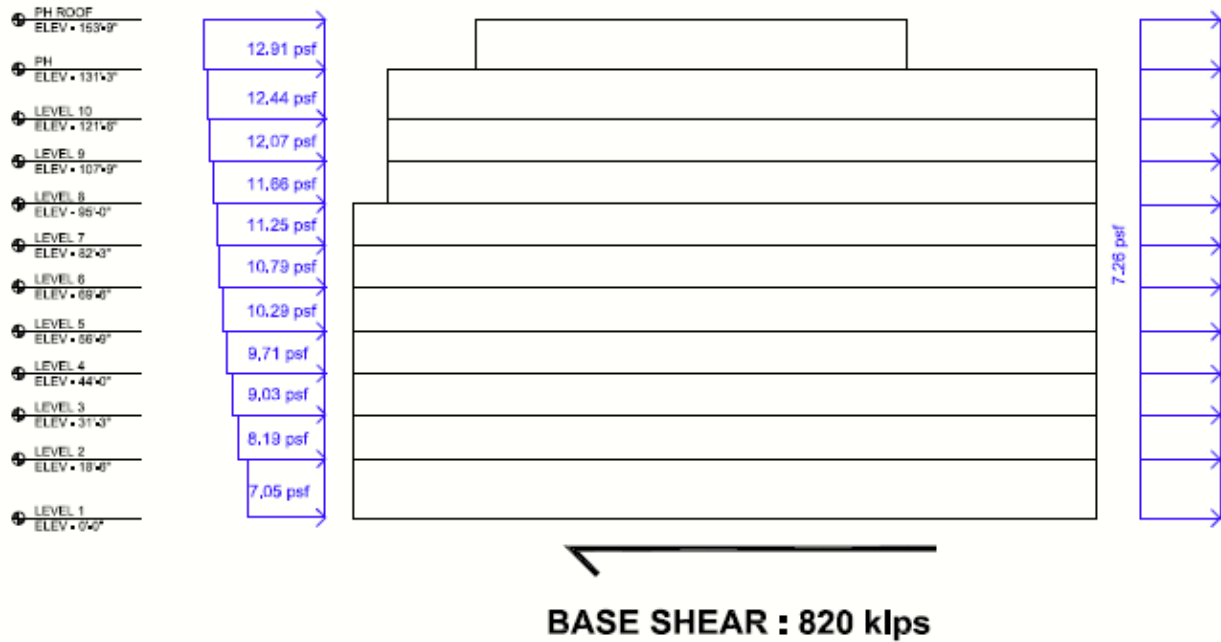

Figure 29: North-South Wind Loads

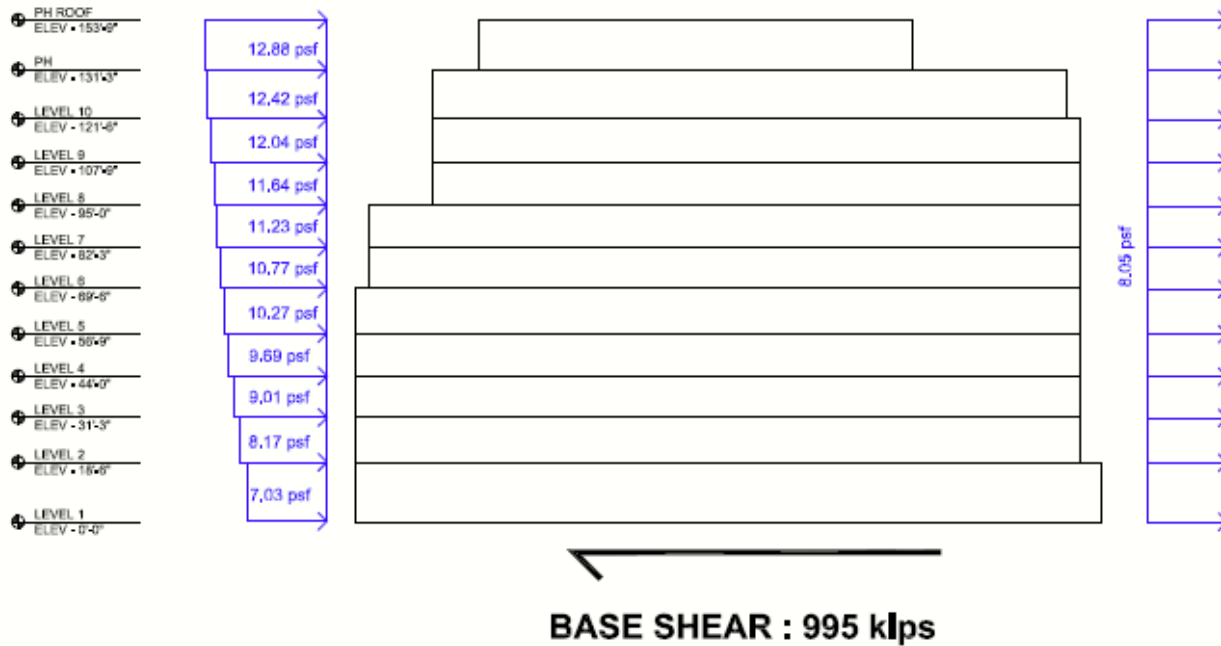

Figure 30: East-West Wind Loads

### Seismic Loads

Seismic calculations of 800 North Glebe were based upon ASCE 7-05 section 12.8 *Equivalent Lateral Force Procedure* for thesis design. For this method to be used, checks to determine if there were any horizontal or vertical irregularities were conducted. Tables 9 and 10 outline the status checks used.

Horizontal Irregularities			
Type	Description	Status	Reference Section
Torsional	Exists when the maximum story drift, computed including accidental torsion, at one end of the structure transverse to an axis is more than 1.2 times the average of the story the two ends of the structure drifts at the two ends of the structure.	X	12.7.3 16.2.2
Extreme Torsional	Exists when the maximum story drift, computed including accidental torsion, at one end of the structure transverse to an axis is more than 1.4 times the average of the story drifts at the two ends of the structure.	OK	NA
Reentrant Corner	Exists where both plan projections of the structure beyond a reentrant corner are greater than 15% of the plan dimension of the structure in the given direction.	OK	NA
Diaphragm Discontinuity	Exists where there are diaphragms with abrupt discontinuities or variations in stiffness, including those having cutout or open areas greater than 50% of the gross enclosed diaphragm area, or changes in effective diaphragm stiffness of more than 50% from one story to the next.	OK	NA
Out-of-Plane Offsets	Exists where there are discontinuities in a lateral force-resistance path, such as out-of-plane offsets of the vertical elements.	OK	NA
Nonparallel System	Exists where the vertical lateral force-resisting elements are not parallel to or symmetric about the major orthogonal axes of the seismic force-resisting system.	OK	NA

Table 9: Horizontal Irregularity Check

Vertical Irregularities			
Type	Description	Status	Reference Section
Stiffness-Soft Story	exist where there is a story in which the lateral stiffness is less than 70% of that in the story above or less than 80% of the average stiffness of the three stories above.	OK	NA
Stiffness Extreme Soft Story	exist where there is a story in which the lateral stiffness is less than 60% of that in the story above or less than 70% of the average stiffness of the three stories above.	OK	NA
Weight (Mass)	exist where the effective mass of any story is more than 150% of the effective mass of an adjacent story. A roof that is lighter than the floor below need not be considered.	OK	NA
Vertical Geometry	exist where the horizontal dimension of the seismic force-resisting system in any story is more than 130% of that in an adjacent story.	OK	NA
In-Plane Discontinuity in Vertical Lateral Force-Resisting Elements	exist where an in-plane offset of the lateral force-resisting elements is greater than the length of those elements or there exists a reduction in stiffness of the resisting element in the story below.	OK	NA
Discontinuity in Lateral Strength-Weak Story	exist where the story lateral strength is less than 80% of that in the story above. The story lateral strength is the total lateral strength of all seismic-resisting elements sharing the story shear for the direction under consideration.	OK	NA
Discontinuity in Lateral Strength-Extreme Weak Story	exist where the story lateral strength is less than 80% of that in the story above. The story lateral strength is the total lateral strength of all seismic-resisting elements sharing the story shear for the direction under consideration.	OK	NA

Table 10: Vertical Irregularity Check

The model output for maximum modal period of vibration was found to be 3.404 seconds. However, this value was not used as the fundamental period because it means the structure is more flexible than what value the code permits for fundamental period of vibration,  $T_a C_u = 1.4845$  s. A lower period of vibration being used for design assumes the lateral resisting structural elements are more rigid and therefore, must be designed for the larger forces. The modal periods of vibration for the structure are found in Table 11 below. Since the lateral shearwall core is centrally located with the majority of the building spread over a large slab area causing the building to significantly rotate. The columns are spread throughout the structure, increasing the stiffness and reducing the torsional effects. Based upon knowledge from research and relevant courses, it was determined for the east-west direction the lateral system could be classified as a dual system with at least twenty-five percent of the forces going to the moment frames. The north-south direction was classified as ordinary reinforced shear walls, where coupling beams were utilized.

	ETABS Output		
	X - Translation	Y - Translation	Z - Rotation
Thesis Redesign	3.404	1.101	1.9734
Existing Structure (Shearwalls Only)	5.6079	1.494	6.1358

Table 11: Modal Periods of Vibration

Design criteria variables used for thesis analysis can be found below in Table 12. Design criteria variables were used to determine story forces at each level, story shear at each level, and base shear, where the output is located in Table 13 for the X-direction and Table 14 for the Y-direction. Figures 31 and 32 were constructed to display how these forces acted on the building in their respective directions, while calculations to support the excel graph below are located in Appendix E.

Design Criteria Variables			
Seismic Use Group		Group II	
Site Class		D	Geotech Report
Seismic Design Category		B	Table 11.6-1
Importance Factor	$I_e$	1.00	Table 11.5-1
Spectral Response Acceleration, Short	$S_s$	0.179	USGS
Spectral Response Acceleration, 1s	$S_1$	0.063	USGS
Site Coefficient	$F_a$	1.6	Table 11.4-1
Site Coefficient	$F_v$	2.4	Table 11.4-2
Soil Modified Acceleration	SMS	0.2864	
Soil Modified Acceleration	$S_{M1}$	0.1512	
Design Spectral Response, short	$S_{ds}$	0.191	USGS
Design Spectral Response, 1s	$S_{d1}$	0.101	USGS
Response Modification Coefficient	RX	5	Table 12.2-1
	RY	5.5	
Approx. Period Parameter	$C_t$	0.02	Table 12.8-2
Building height (above grade)	$h_n$	153.75	
Approx. Period Parameter	$x$	0.75	Table 12.8-2
Approx. Fundamental Period	$T_a$	0.873	Eq. 12.8-8
Calculated Period Upper Limit Coefficient	$C_u$	1.7	Table 12.8-1
	$T_a C_u$	1.483	12.8.2
Long Period Transition Period	$T_L$	8	Figure 22-15

		X-Dir	Y-Dir	
	$T_a$	0.873	0.873	$C_t * h^x$
	$T_b$	3.404	1.1	ETABS
Seismic Response Coefficient	$C_s = \min$	0.0382	0.0347	$SDS / (R/I)$
		0.0136	0.0166	$SD1 / (T(R/I))$
		0.0732	0.1209	$SD1 * TL / (T^2(R/I))$
Building Weight (kips)	$W$	49641.84	49641.84	
Base Shear	$V_b$	674.1369	826.0391	$C_s \times W$
Structural Period Exponent	$k$	1.492267	1.492267	12.8.3

Table 12: Seismic Design Variables

X-Direction							
Level (i)	Story Height (h <sub>i</sub> )	Height Above Ground (h)	Story Weight (w (kips))	w*h <sub>k</sub>	C <sub>vx</sub>	Lateral Story force (f <sub>i</sub> )	Story Shear (V <sub>i</sub> )
PHR	18.5	153.75	524.51	961755.3	0.03	19.72	19.72
Roof	13.75	135.25	4181.11	6331661	0.19	129.81	149.53
10	13.75	121.5	4355.72	5620890	0.17	115.24	264.77
9	12.75	107.75	4342.48	4684330	0.14	96.04	360.81
8	12.75	95	4350.33	3888786	0.12	79.73	440.54
7	12.75	82.25	4546.41	3277650	0.10	67.20	507.74
6	12.75	69.5	5344.45	2996653	0.09	61.44	569.18
5	12.75	56.75	5321.16	2204916	0.07	45.21	614.38
4	12.75	44	5459.97	1547608	0.05	31.73	646.11
3	12.75	31.25	5354.67	910853.5	0.03	18.67	664.79
2	18.5	18.5	5861.03	455966.4	0.01	9.35	674.14
			49641.8373	32881069			
Level (i)	Story Height (h <sub>i</sub> )	Height Above Ground (h)	B <sub>y</sub>	5%B <sub>y</sub>	A <sub>x</sub>	M <sub>i</sub> (ft-k)	M <sub>i</sub> (in-k)
PHR	18.5	153.75	215	10.75	1.0	212	2543.6
Roof	13.75	135.25	215	10.75	1.0	1395	16745.9
10	13.75	121.5	215	10.75	1.0	1239	14866.1
9	12.75	107.75	215	10.75	1.0	1032	12389.1
8	12.75	95	215	10.75	1.0	857	10285.0
7	12.75	82.25	215	10.75	1.0	722	8668.7
6	12.75	69.5	215	10.75	1.0	660	7925.5
5	12.75	56.75	215	10.75	1.0	486	5831.5
4	12.75	44	215	10.75	1.0	341	4093.1
3	12.75	31.25	215	10.75	1.0	201	2409.0
2	18.5	18.5	215	10.75	1.0	100	1205.9
							86963.7

Table 13: North-South Seismic Forces

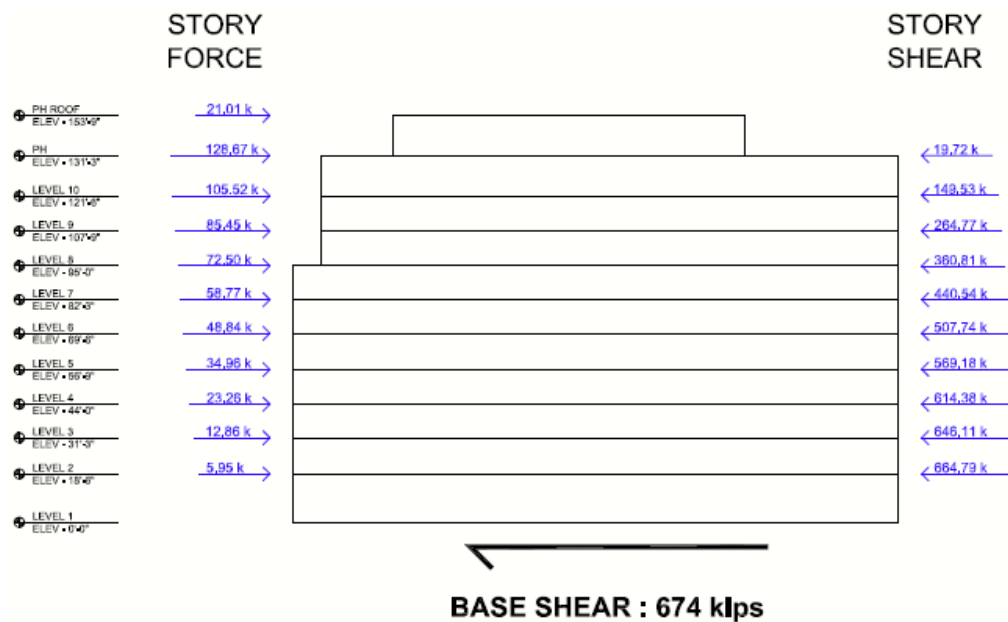

Figure 31: North-South Building Loads

Y-Direction							
Level (i)	Story Height (h <sub>i</sub> )	Height Above Ground (h)	Story Weight (w (kips))	w*h <sub>k</sub>	C <sub>vix</sub>	Lateral Story force (f <sub>i</sub> )	Story Shear (V <sub>i</sub> )
PHR	18.5	153.75	524.51	961755.3	0.03	24.16	24.16
Roof	13.75	135.25	4181.11	6331661	0.19	159.06	183.23
10	13.75	121.5	4355.72	5620890	0.17	141.21	324.43
9	12.75	107.75	4342.48	4684330	0.14	117.68	442.11
8	12.75	95	4350.33	3888786	0.12	97.69	539.81
7	12.75	82.25	4546.41	3277650	0.10	82.34	622.15
6	12.75	69.5	5344.45	2996653	0.09	75.28	697.43
5	12.75	56.75	5321.16	2204916	0.07	55.39	752.82
4	12.75	44	5459.97	1547608	0.05	38.88	791.70
3	12.75	31.25	5354.67	910853.5	0.03	22.88	814.58
2	18.5	18.5	5861.03	455966.4	0.01	11.45	826.04
			49641.84	32881069			
Level (i)	Story Height (h <sub>i</sub> )	Height Above Ground (h)	B <sub>y</sub>	5%B <sub>y</sub>	A <sub>x</sub>	M <sub>2</sub> (ft-k)	M <sub>2</sub> (in-k)
PHR	18.5	153.75	250	12.5	1.0	302	3624.2
Roof	13.75	135.25	250	12.5	1.0	1988	23859.6
10	13.75	121.5	250	12.5	1.0	1765	21181.2
9	12.75	107.75	250	12.5	1.0	1471	17652.0
8	12.75	95	250	12.5	1.0	1221	14654.1
7	12.75	82.25	250	12.5	1.0	1029	12351.2
6	12.75	69.5	250	12.5	1.0	941	11292.3
5	12.75	56.75	250	12.5	1.0	692	8308.8
4	12.75	44	250	12.5	1.0	486	5831.9
3	12.75	31.25	250	12.5	1.0	286	3432.4
2	18.5	18.5	250	12.5	1.0	143	1718.2
							123905.9

Table 14: East-West Seismic Forces

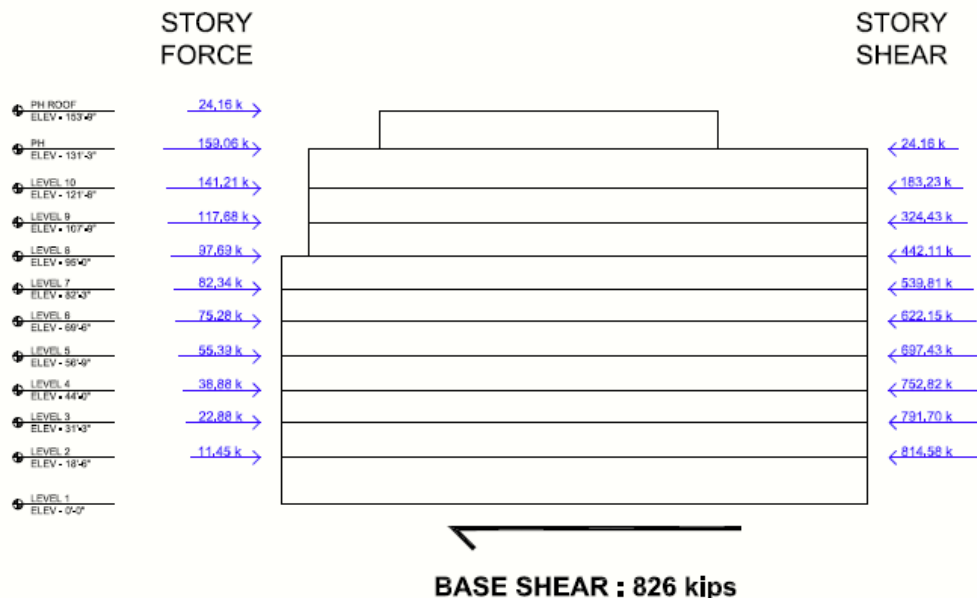

Figure 32: East-West Seismic Building Loads

## **Design Process – Load Path and Distribution**

Loads travel throughout a building's structure laterally and vertically until they reach the ground. The path which loads are distributed is based on member relative stiffness. The members with a higher relative stiffness have larger forces induced into them. Concrete moment frames are incorporated into the east-west lateral system, while shear walls with coupling beams participate in the north-south direction. Coupled shear walls act as a unit when resisting lateral loads. The coupling beams present are composed of the floor slab with increased reinforcement. Their stiffness was based upon slab width and wall thickness.

The code is not very specific about how a two-way post tensioned slab can be accounted for in a lateral resisting system. It is not explicitly stated what calculations are used for determining force distribution, but there have been published engineering research journals on the subject matter.

Pushover analysis research performed by Virote Boonyapinyo, Pennung Warnitchai and Nuttawuk Intaboot on the seismic capacity of post-tensioned slab-column frame building determined the seismic capacity for these systems. Their model was of a 9-story lat-plate building: with and without shearwalls. They had determined that a slab-column system combined with drop panels and shear walls had significant increases in strength and stiffness. Gross member properties are used for slab-beams and columns, along with effects of shear caps being included which increase the flexural stiffness of the slab-column connection. Their findings determined the failure mechanism of slab-beam flexural yielding resulted in considerable building stiffness decrease and the building behaved as a strong column-weak beam mechanism. Drop panels increased the lateral capacity by almost 18% and shear walls increased it by nearly 40%.

Given that the banded tendons along the east-west direction in the column strip were modeled as extremely wide-shallow beams in a moment resisting frame, the lateral loads were transferred through the rigid diaphragm to the beams and finally to either the supporting columns or the shear walls. Shear walls were assumed to not take any out-of-plane forces, but in reality the walls orthogonal to the applied loads would participate by acting similar to the flanges of a steel W-shape.

Research paper 258 for the 8<sup>th</sup> Nations Conference on Earthquake Engineering was also referenced in thesis redesign. Results from their research determined positive moment developed on one side of the slab-column connection and bottom reinforcement should be provided to reduce the possibility of large crack formation. Some of the authors had also



performed similar lateral loading experiments and discussed their findings in “Hysteretic behavior of exterior post-tensioned flat plate connections”. They had observed that tendon layout greatly influenced the lateral drift capacity, dissipated energy, failure mechanism, and ductility of the structure. Flexural capacity was met by the post-tensioned tendons prior to punching shear failure, unlike mild reinforcement. Banded tendon layouts had inferior lateral drift capacity, energy dissipation capacity, and punching shear resistance. Use on bonded bottom reinforcement was recommended to provide resistance to moment reversal in high seismic regions.

### **Design Process – ETABS Computer Model**

A computer model was created using ETABS, Computer and Structures Inc. structural modeling and analysis program. The model included the entire structural system of columns, beams and shear walls because their stiffness would participate in transferring lateral forces. Figure 33 depicts columns and shear walls in red, column strips in yellow and the concrete slab in green. Results from the model determined the center-of-rigidity and elements’ stiffness and story displacements. Load combinations were entered manually into ETABS based on AISC 7-05. Analysis assumptions that were included in the ETABS model include, but are not limited to:

- Rigid diaphragms modeled at each floor level.
- P-Delta effects taken into account.
- All restraints on the bottom level were modeled as fixed.
- Structural members were modeled without their material properties mass per unit area.
- Shear walls modeled as shell elements meshed into areas with a maximum dimension of 24”x24” to allow for the walls to act as a rigid unit.
  - Shell element resistance properties were manual reduced to minimize the walls capabilities of taking out-of-plane bending.
- Beams and columns were modeled as line elements.
- The moment of inertias of columns and portions of the shears walls were reduced to  $0.7I_g$ . This is done to account for inelastic response of members and the decrease in effective stiffness.
- Beam elements included a 0.5 rigid end offset multiplier that assume each end to be 50% rigid for bending and shear deformation.
- Seismic loads were applied to the center-of-mass of each floor diaphragm.
- Wind Loads were applied at the center-of-pressure.
- Coupling beams act between the shear wall returns.
  - Coupling beams are sized to be the thickness of the slab, width of the shear wall and material properties of the slab.

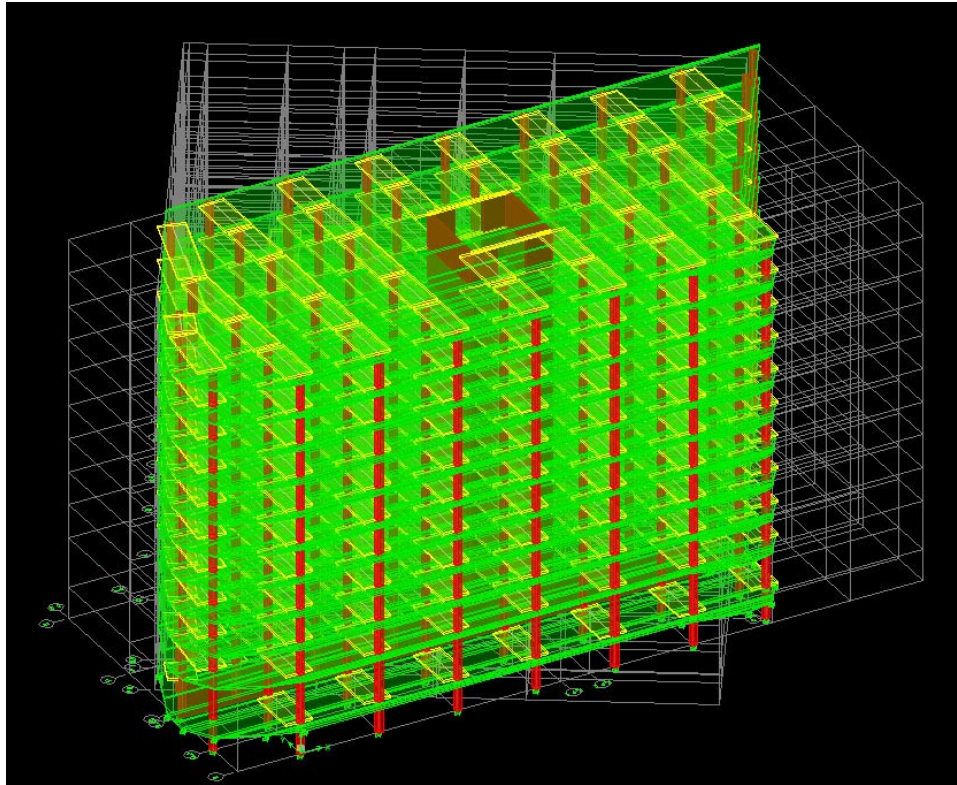

Figure 33: ETABS Model

### **Design Process – Rigidity and Relative Stiffness**

Eccentricities resulting from lateral loads not being applied at the center-of-rigidity (COR) cause torsion on the building. Wind loads are applied at the center-of-pressure (COP), while seismic forces are applied at the center-of-mass (COM). In the case of 800 North Glebe, neither of these two centers coincides with the COR. Refer to Table 15 and Figure 34 to view the difference of the COM to the COR. The floor plan displayed shows all the members participating in the LFRS, which include shearwalls, columns and idealized banded tendon column strips.

Story	Center of Mass (in)		Center of Rigidity (in)		Eccentricity (in)	
	XCM	YCM	XCR	YCR	ex	ey
MAIN ROOF	1128.1	690.3	1202.9	875.5	-74.8	-185.2
10TH	1128.1	690.3	1207.5	872.1	-79.4	-181.8
9TH	1128.1	690.3	1212.1	869.1	-84.0	-178.8
8TH	1128.1	690.3	1216.5	865.4	-88.4	-175.1
7TH	1128.1	690.3	1220.7	860.1	-92.6	-169.8
6TH	1089.1	867.6	1225.1	849.4	-136.0	18.2
5TH	1089.1	867.6	1231.5	827.5	-142.4	40.2
4TH	1087.9	887.2	1237.4	801.9	-149.6	85.4
3RD	1087.9	887.2	1242.4	776.7	-154.6	110.5
2ND	1089.1	886.6	1246.9	757.4	-157.9	129.2

Table 15: Eccentricity Determination

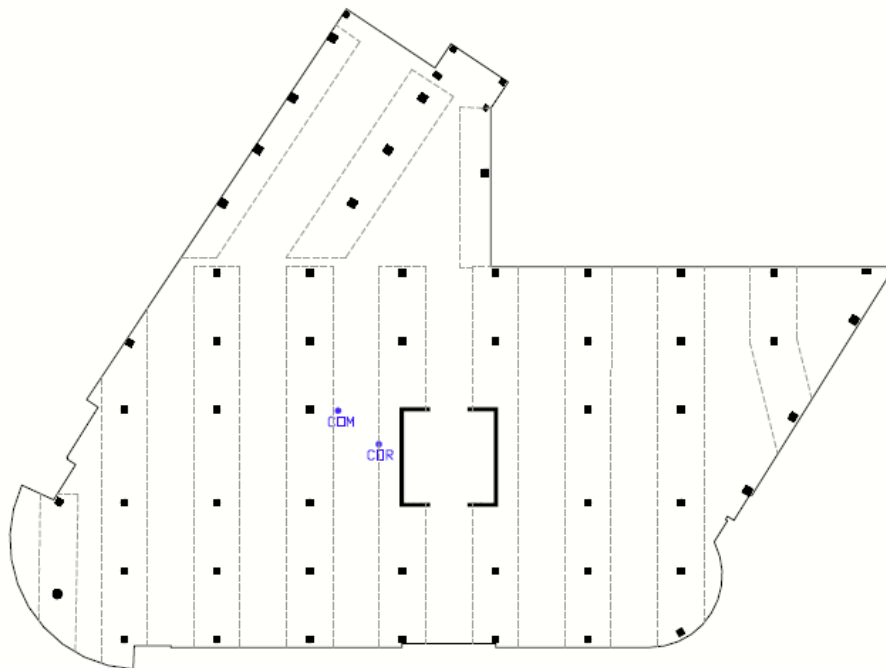

Figure 34: COM vs. COR

### Design Process – Torsion

The eccentricity of the COM to the COR causes a torsional moment on the building. AISC 7-05 section 12.8.4 was used to determine this total moment produced by inherent torsion and accidental torsion. Inherent torsion is, as stated by section 12.8.4.1, “For diaphragms that are not flexible, the distribution of lateral forces at each level shall consider the effect of the inherent torsional moment,  $M_t$ , resulting from eccentricity between the locations of the center-of-mass and the center of rigidity.” Accidental torsion is, as specified by section 12.8.4.2, “The accidental torsional moments,  $M_{ta}$ , (kip) caused by assumed displacement of the center-of-mass each way from its actual location by a distance equal to 5 percent of the dimension of the structure perpendicular to the direction of the applied forces.” To obtain the overall building moment,  $M_{ta}$  was added to  $M_t$ , creating the largest torsional moment, shown in Table 16.

Floor	Torsional Moment							
	North-South Direction (Short Wall Resisting)				East-West Direction (Long Wall Resisting)			
	Floor Lateral Force (k)	$M_t$ (ft-k)	$M_{ta}$ (ft-k)	$M_t$ total (ft-k)	Floor Lateral Force (k)	$M_t$ (ft-k)	$M_{ta}$ (ft-k)	$M_t$ total (ft-k)
Main Roof	108.4	-20078.6	1165.3	21244.0	131.0	-9799.2	1637.4	11436.5
10	90.5	-16447.9	972.4	17420.3	109.4	-8682.1	1367.5	10049.6
9	85.3	-15255.9	917.4	16173.3	103.3	-8673.7	1291.2	9964.9
8	80.2	-14041.7	862.0	14903.6	97.2	-8584.4	1214.4	9798.8
7	78.1	-13255.8	839.3	14095.1	94.7	-8766.3	1183.8	9950.2
6	75.7	1381.3	813.7	-567.6	91.9	-12500.8	1149.3	13650.1
5	72.9	2928.5	784.0	-2144.5	88.7	-12637.0	1109.2	13746.2
4	69.6	5942.4	748.1	-5194.2	84.9	-12693.1	1060.8	13753.9
3	65.3	7211.1	701.5	-6509.7	79.8	-12338.5	997.9	13336.4
2	31.4	4053.5	337.3	-3716.2	38.5	-6072.6	480.8	6553.4
			<b>Total</b>	<b>65704.0</b>			<b>Total</b>	<b>112240.0</b>

Table 16: Torsional Moment

It was found that the torsional moment in the east-west direction was larger. This is primarily due to the fact that the building shape does not step back on the perpendicular face, and therefore, the eccentricity stays the same the entire height of the building. The torsional moment in the other direction changes signs on the sixth floor, where the major building set back occurs, switching the eccentricity from negative to positive.

### Design Process – Shear

A building experiences a direct shear and possibly a torsional shear when a lateral loads are applied. Direct shear is the force acting on the floor diaphragms applied directly to the lateral resisting members. To determine the direct shear, the story shear was multiplied by the relative stiffness of each participating member.

Torsional shear is the force cause by eccentricity. The torsional shear is similar to torsional moment, as it takes into account the difference in distance from the COM to the COR. The following equation was used to determine the torsional shear.

$$V_i = \frac{V_{tot} e d_i k_i}{J}$$

*V<sub>i</sub>* = torsional shear of element *i*

*V<sub>tot</sub>* = story shear

*e* = distance from COM to COR

*d<sub>i</sub>* = distance from element *i* to COR

*k<sub>i</sub>* = relative stiffness of element *i*

*J* =  $\sum k_i \times d_i^2$

A strength check must be performed to verify that each member is capable of transferring both direct and torsional shear. ACI 381-08 section 21.9.4.1, *Special Structural Walls and Coupling Beams Shear Strength* was used for the central core shear walls, and it states:

$$V_n = A_{cv} \left[ \left( \alpha_c \lambda \sqrt{f'_c} \right) + (\rho_t f_y) \right]$$

This equation recognizes the higher shear strength of walls with high shear-to-moment ratios. Where chord reinforcement is provided near wall edges in concentrated amounts for resisting bending moments, reinforcement should not be include in calculating  $\rho_t$ . However, the extra steel provided in the short shear walls is included for resisting shear forces and therefore shall be accounted for in thesis calculations.

The shear walls included in the duel system were analyzed and the flexural reinforcement was calculated. Maximum moment values from ETABS were used in the calculations and it was concluded 57in<sup>2</sup> would be needed in the outer 10' on either side. Reinforcement could be reduced if axial loads were included in the ETABS model, but for computer analysis programming purposes this was not included.

## Design Process – Drift and Displacement

Story drift and lateral displacements are not considered strength design concerns but are regarded as serviceability issues. Seismic drift is addressed in AISC 7-05 while wind drift is not addressed in the code, but, is normally limited to L/400, based on standard engineering practice over the years. In the case of 800 North Glebe:

$$\text{Wind: } \Delta_{\max} = (153.75' \times 12''/1') / 400 = 4.61''$$

The max wind displacement in the east-west direction (i.e. long shearwalls resisting), from ETABS was calculated to be 0.6326". The calculated displacement at the main roof level is well below the allowable wind displacement of 4.61". When looking at the north-south direction (i.e. short walls resisting), the displacement at the main roof level was found to be 3.2046" from ETABS. Table 17 summarizes the max point displacement per floor.

Story	North-South (X) Direction				East-West (Y) Direction			
	Wind Load Combo		Seismic Load Combo		Seismic Load Combo		Wind Load Combo	
	UX	UY	UX	UY	UY	UX	UY	UX
MAIN ROOF	3.2046	0.0575	3.1034	0.0917	0.6326	-0.1356	0.4349	-0.066
10TH	2.9021	0.0522	2.8194	0.0869	0.5918	-0.1265	0.3908	-0.0577
9TH	2.5783	0.0453	2.5121	0.0807	0.5395	-0.1158	0.3417	-0.0491
8TH	2.2303	0.0373	2.1776	0.0733	0.4783	-0.1032	0.2919	-0.0408
7TH	1.8608	0.0282	1.8196	0.0647	0.3822	-0.1236	0.242	-0.0329
6TH	1.4797	0.0174	1.4489	0.0539	0.338	-0.0734	0.1921	-0.025
5TH	1.0975	0.004	1.0761	0.0384	0.2675	-0.0577	0.1441	-0.0172
4TH	0.7358	-0.0058	0.723	0.024	0.1964	-0.0417	0.1046	-0.0124
3RD	0.4404	0.0003	0.411	0.0121	0.1279	-0.0265	0.0675	-0.0078
2ND	0.1938	0.0035	0.1663	0.0041	0.0653	-0.0129	0.0344	-0.0037

Table 17: Max Point Displacement

Interstory drift was calculated by ETABS for both load cases and can be found in the Tables 18 below. These values do not represent the corrected drift calculation which includes  $C_d$ . Corrected values are summarized in Table 19. The limits for interstory drifts at typical floors (12'-9") are 0.375" for wind and the equations for seismic as seen below.

$$\text{Design: } \delta_x = \frac{C_d \delta_{xe}}{I}$$

$$\text{Code: } \Delta_a = 0.02h_{sx}$$

Interstory displacements from the ETABS model is significantly less than the allowable limits for both load cases. The values from floor-to-floor do not deviate from one another by any significant value, with the exception of the 2<sup>nd</sup> level. Complete tables of drift and displacement values may be found in Appendix E while summaries are found below in Tables 21. Table 22 represents the corrected drift, which takes into account  $C_d/I$ .

Story	Max Drift with Respect to $h_n$			
	Seismic Load Combo		Wind Load Combo	
	Drift Y	Drift X	Drift Y	Drift X
MAIN ROOF	0.000266	0.001856	0.000288	0.001977
10TH	0.000342	0.002009	0.000321	0.002117
9TH	0.0004	0.002186	0.000325	0.002275
8TH	0.000445	0.00234	0.000327	0.002415
7TH	0.000471	0.002423	0.000326	0.002491
6TH	0.000461	0.002437	0.000329	0.002498
5TH	0.000464	0.002308	0.000306	0.002364
4TH	0.000448	0.002039	0.000263	0.002089
3RD	0.000409	0.001599	0.000216	0.001635
2ND	0.00029	0.000739	0.000084	0.000861

Table 18: Uncorrected Interstory Drifts

Story	Max Drift with Respect to $h_n$			
	Seismic Load Combo		Wind Load Combo	
	Drift Y	Drift X	Drift Y	Drift X
MAIN ROOF	0.001197	0.008352	0.001296	0.0088965
10TH	0.001539	0.0090405	0.0014445	0.0095265
9TH	0.0018	0.009837	0.0014625	0.0102375
8TH	0.0020025	0.01053	0.0014715	0.0108675
7TH	0.0021195	0.0109035	0.001467	0.0112095
6TH	0.0020745	0.0109665	0.0014805	0.011241
5TH	0.002088	0.010386	0.001377	0.010638
4TH	0.002016	0.0091755	0.0011835	0.0094005
3RD	0.0018405	0.0071955	0.000972	0.0073575
2ND	0.001305	0.0033255	0.000378	0.0038745

Table 19: Corrected Interstory Drifts

## Column Design

### Design Loads

Original column layout for 800 North Glebe required 30"x30" reinforced concrete columns. The new column layout increased the total number of columns and removed the need for post-tensioned girders while reducing the tributary area per column. A standard interior column, as seen in Figure 35 was designed to resist axial loads and moments induced by the slab gravity and lateral loads. A table of the axial gravity loads for the selected column is shown below in Table 20. Moment forces used in design were taken from RAM Concept and ETABS models.

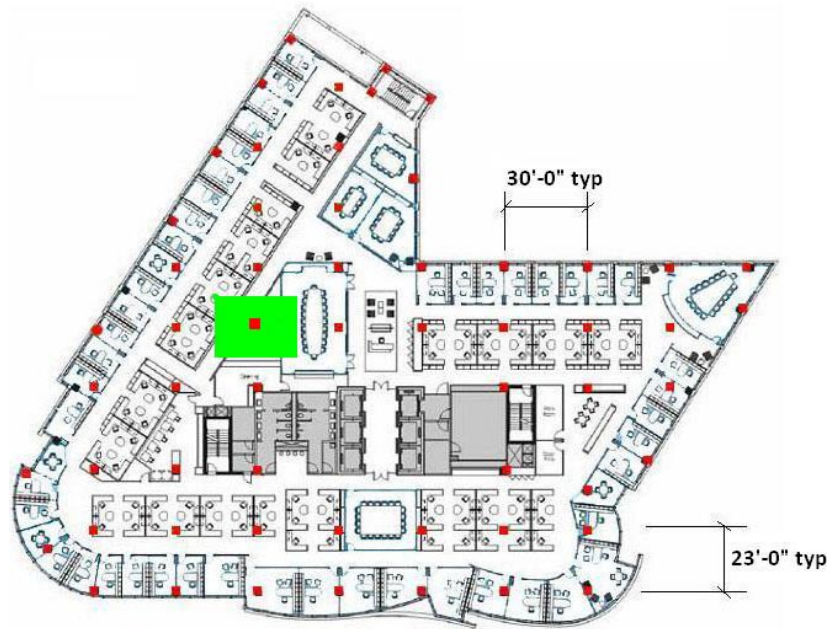

Figure 35: Standard Interior Column

Floor	Tributary Width (ft <sup>2</sup> )	Dead Load (lb)	Live Load (lb)	Superimposed Dead Load (lb)	Total Dead Load (lb)	Snow Load (lb)	1.4DL (kips)	1.2DL + 1.6LL (kips)	1.2DL + 1.6S + L (kips)	Total Load (kips)
Roof	660	66000	66000	16500	82500	16500	115.5	204.6	191.4	204.6
10	660	66000	66000	16500	82500	0	115.5	204.6	165.0	409.2
9	660	66000	66000	16500	82500	0	115.5	204.6	165.0	613.8
8	660	66000	66000	16500	82500	0	115.5	204.6	165.0	818.4
7	660	66000	66000	16500	82500	0	115.5	204.6	165.0	1023.0
6	660	66000	66000	16500	82500	0	115.5	204.6	165.0	1227.6
5	660	66000	66000	16500	82500	0	115.5	204.6	165.0	1432.2
4	660	66000	66000	16500	82500	0	115.5	204.6	165.0	1636.8
3	660	66000	66000	16500	82500	0	115.5	204.6	165.0	1841.4
2	660	66000	66000	16500	82500	0	115.5	204.6	165.0	2046.0
1	660	66000	66000	16500	82500	0	115.5	204.6	165.0	2250.6

Table 20: Column Axial Loads



Slab Gravity Moment (RAM Concept)					Lateral Load Moment (ETABS)				
Floor	Interior Column		Exterior Column		Floor	Interior Column		Exterior Column	
	Axial (k)	Moment ft-k)	Axial (k)	Moment ft-k)		Axial (k)	Moment ft-k)	Axial (k)	Moment ft-k)
Roof	204.6	320	122.8	206	Roof	204.6	NA	122.8	NA
10	409.2	320	245.5	206	10	409.2	224	245.5	NA
9	613.8	320	368.3	206	9	613.8	321	368.3	NA
8	818.4	320	491.0	206	8	818.4	368	491.0	NA
7	1023.0	428	613.8	280	7	1023.0	460	613.8	NA
6	1227.6	428	736.6	280	6	1227.6	540	736.6	NA
5	1432.2	428	859.3	280	5	1432.2	580	859.3	NA
4	1636.8	428	982.1	280	4	1636.8	630	982.1	NA
3	1841.4	428	1104.8	280	3	1841.4	643	1104.8	NA
2	2046.0	428	1227.6	280	2	2046.0	716	1227.6	NA
1	2250.6	428	1350.4	280	1	2250.6	623	1350.4	NA

Table 21: Column Axial and Moment Loads

### **Design Process – Strength Calculation and Detailing**

Exterior columns usually carry smaller gravity loads but have larger tensile forces induced by lateral loads. This predominantly results in higher reinforcement percentages. The aforementioned loads were used to design initial column sizes and were then entered into PCA Column to be analyzed. Reinforcing for the columns concerned itself with both gravity and lateral design, where a general reinforcing can be found in Table 22.

Floor	Tributary Width (ft <sup>2</sup> )	Column Size	Quantity	Rebar	
Roof	660	16x16	24	#5	8
10	660	24x24	41	#8	12
9	660	24x24	41	#8	12
8	660	24x24	41	#8	12
7	660	24x24	44	#8	12
6	660	24x24	44	#8	12
5	660	24x24	44	#8	12
		30x30	7	#9	16
4	660	24x24	44	#8	12
		30x30	7	#9	16
3	660	24x24	44	#8	12
		30x30	8	#9	16
2	660	30x30	52	#9	16
1	660	30x30	52	#9	16

Table 22: Column Sizing

Detailed calculations for typical columns may be found in Appendix D. Typical column reinforcing details can be seen below in the images of Figure 36.

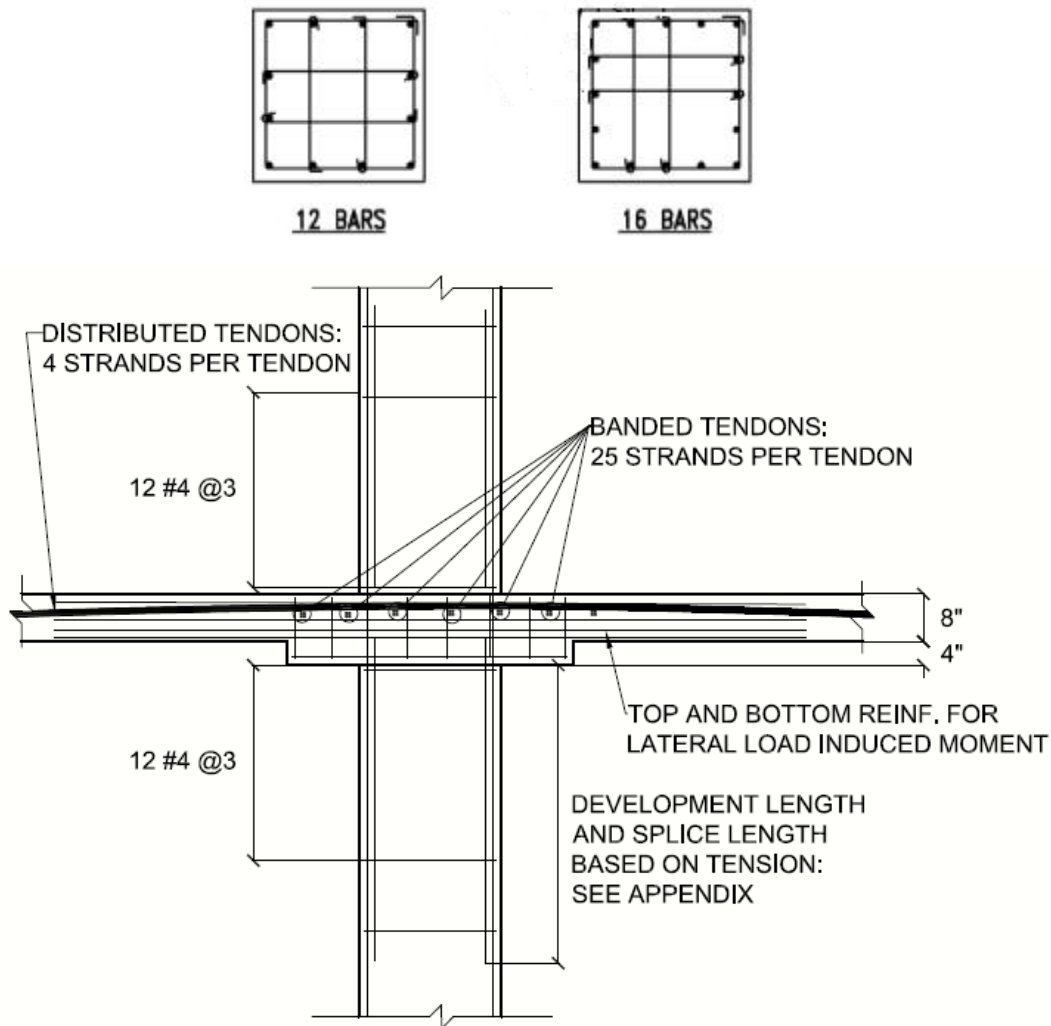

Figure 36: Typical Column Reinforcing Plan and Section

Based on ACI 318-08, rebar development lengths and splicing requirements shall conform to Cass B provisions. Lap Splices are a multiple of the tensile development length  $l_d$ , which is calculated in accordance with section 12.2:

$$l_d = \frac{f_y \phi_t \phi_e}{20 \tau \sqrt{f'_c}} d_b$$

The modified column grid had only been implemented into the superstructure layout and below grade levels were not able to be drastically modified because of parking requirements. A

nondirect load path was caused, as seen in Figure 37, and required a row of columns to be designed with a slope.

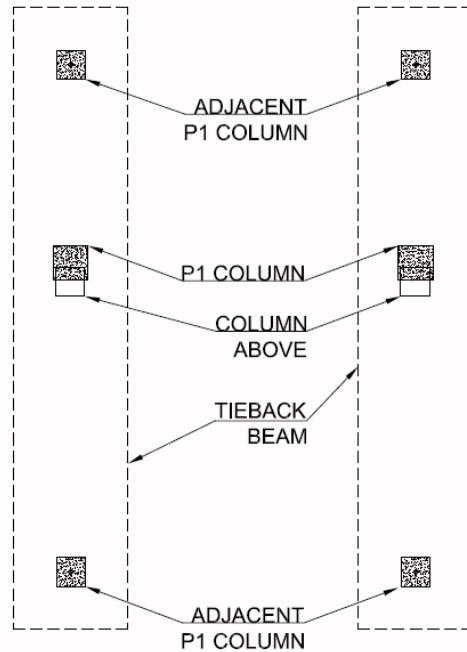

Figure 37: Sloped Column Plan

The columns below the first level do not lie directly under the offset sloped column base, leading to eccentricity and large shear forces on first sublevel columns. Tension was also introduced into the slab around these ground level columns. To resist the high forces in those areas, column corbels and transfer beams were required to be designed using ACI 318 section 11.8. Detailing for the sloped column and corbel are seen in Figure 38.

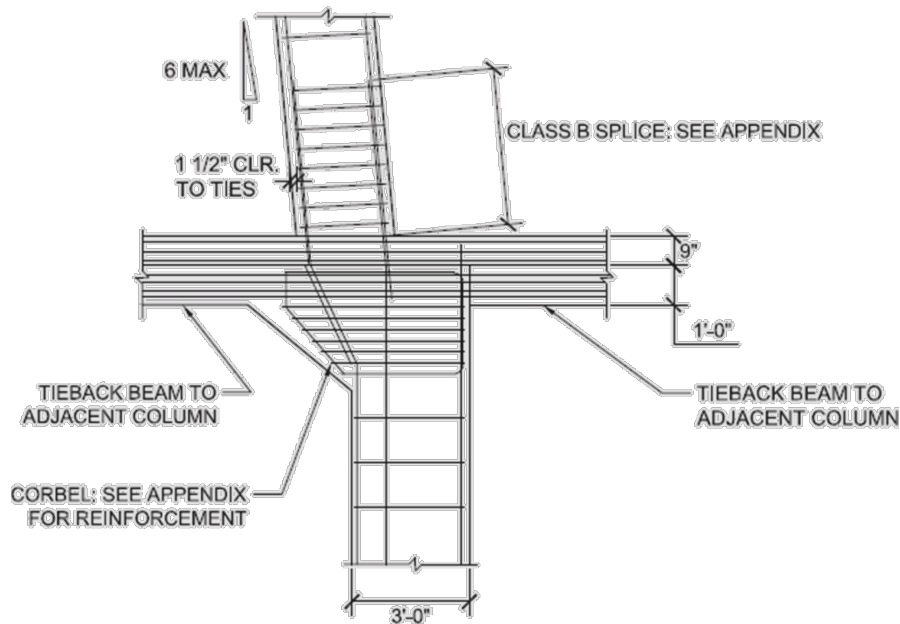

Figure 38: Sloped Column Reinforcing

## Foundation Impacts

### Overturing and Addition Building Weight

Overturing moments are an important effect to consider because they affect various parts of the building, primarily the foundations. 800 North Glebe includes three levels of below grade parking supported by 30"x30" and 36"x36" reinforced concrete columns. The outer columns along the east face of the building are tied into 72" diameter concrete caissons. The shear walls are supported by a 6'-0" thick concrete mat foundation 58'-6" wide by 45'-4" long.

The size of the supporting foundations was analyzed because of the column layout alteration. Most of the foundation sizes were reduced, but the required number of foundations was increased. The overturning moment, similar to the other calculations, were preformed with wind loads being controlled by case 1. The overturning values for both wind directions are in Table 23 below. Using load case 6, there was an upward reaction on the supporting structure because from the ETABS output. However, gravity loads were not taken into account for the lateral force computer model. The maximum upward reaction was 332 kips and the maximum gravity force reaction on this region is ten times greater.

			North/South Wind		East/West Wind	
	Floor	Building Height (ft)	story force (k)	Overturing Moment (ft-k)	story force (k)	Overturing Moment (ft-k)
	PH Roof	153.8	62.7	9639.2	75.7	11643.8
	PH	135.3	108.4	14661.5	131.0	17716.3
	10	121.5	90.5	10990.4	109.4	13291.8
	9	107.8	85.3	9194.8	103.3	11129.9
	8	95.0	80.2	7617.3	97.2	9229.5
	7	82.3	78.1	6421.6	94.7	7789.7
	6	69.5	75.7	5260.7	91.9	6390.1
	5	56.8	72.9	4138.8	88.7	5035.9
	4	44.0	69.6	3062.1	84.9	3734.1
	3	31.3	65.3	2039.1	79.8	2494.6
	2	18.5	31.4	580.5	38.5	711.6
	1	0.0	0.0	0.0	0.0	0.0
<b>Σ Total Overturing Moment (ft-k)=</b>				<b>73606</b>		<b>89167</b>

Table 23: Overturing Moment

## **System Comparison and Conclusion**

Modifying the structural slab system from a one-way mildly reinforced slab over post-tensioned girders to a two-way post-tensioned flat plate slab added some inherent benefits to the structural behavior. Reducing the slab thickness from 9" to 8" and removing the need for beams minimized building weight. Deflection for the redesigned slab was determined to meet all ACI 318-08 criteria limits.

The reduction in weight helped to reduce the modal response for both translation directions and for the rotation. Implementing the post-tensioned slab into the lateral force resisting system allowed for the concrete moment frame to take part of the forces and not rely solely on the shear wall core resisting lateral loads. Based upon the impact on the gravity and lateral force resisting systems, the new post-tensioned redesign is a viable alternative.

Master level courses used during the structural depth study include 538: *Earthquake Resistant Design of Buildings* and AE 597A: *Computer Modeling*. The theory of seismic structural behavior learned from these courses gave a broader understanding of how 800 North Glebe should react under such loading. The use of a computer model was vital to the analysis. This allowed for an integrated system design, in which structural members participate with one another.

## **Architectural Breadth**

To accommodate for the slab system redesign, two rows of columns were added. The increase in columns meant the architectural floor plans needed to be altered. The existing layout was studied to determine the proper size of rentable offices and cubicles and great effort was made to keep the same ratios. So as to not diminish the number of offices available, interior partition walls being moved around were kept to as minimal as possible. The owner of 800 North Glebe would like to keep the mix-use office building as a class-A space, and not reduce what they can offer their tenants.

## **Floor Plan Redesign**

### **Design Process**

Floor plans for the current architectural floor plans were available for levels three, five, eight and ten. An office breakdown of the available floors can be seen in Table 24. These levels were assumed to be the same for adjacent floor and therefore not all of the levels were analyzed. Figures 39, 41, 43 and 45 represent the existing office plans created by the architect. Thesis redesign of floor plans can be found in Figures 40, 42, 44, and 46.

<b>Level</b>	<b>Typical Office</b>	<b>Small Office</b>	<b>Large office</b>	<b>Exec. Office</b>	<b>Total Offices</b>	<b>Work stations</b>
3	35	0	11	1	47	79
5	34	0	0	0	34	83
8	23	12	19	1	55	16
10	12	0	5	1	18	65

Table 24: Office Layout Count

### LEVEL 3

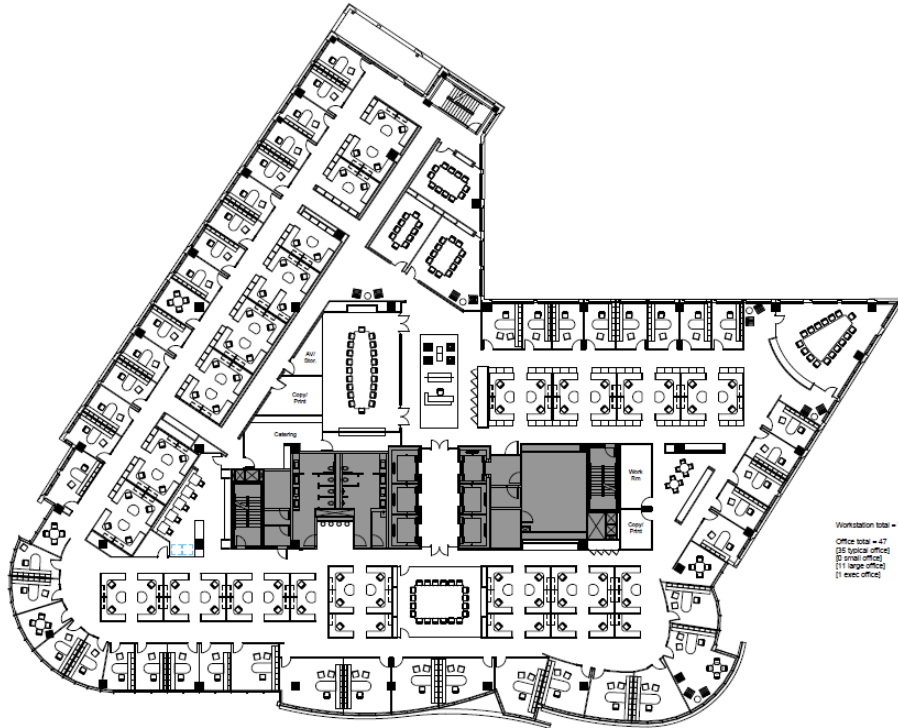

Figure 39: Existing Level 3 Plan



Figure 40: Thesis Level 3 Redesign Plan

## LEVEL 5

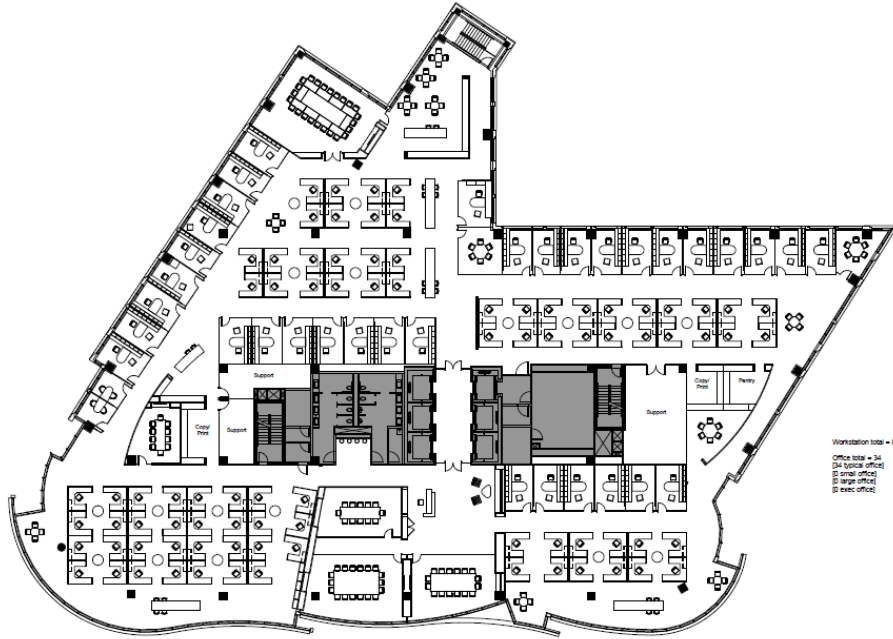

Figure 41: Existing Level 5 Plan



Figure 42: Thesis Level 5 Redesign Plan



## LEVEL 8



Figure 43: Existing Level 8 Plan



Figure 44: Thesis Level 8 Redesign Plan

### LEVEL 10

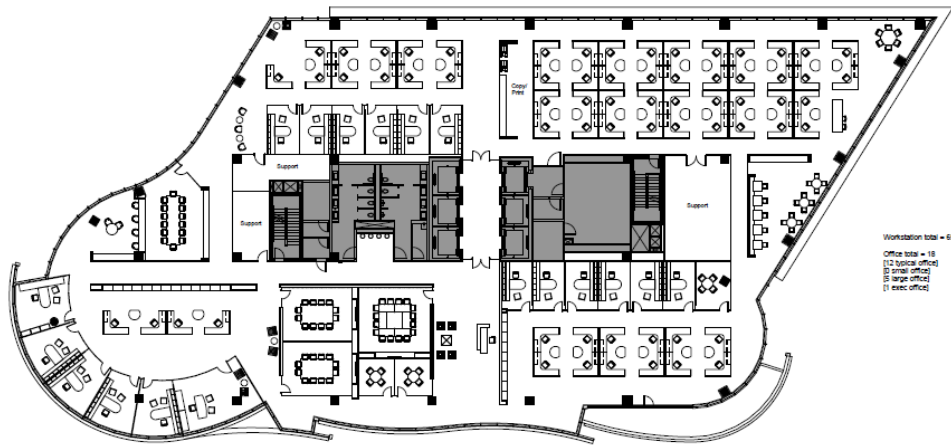

Figure 45: Existing Level 10 Plan

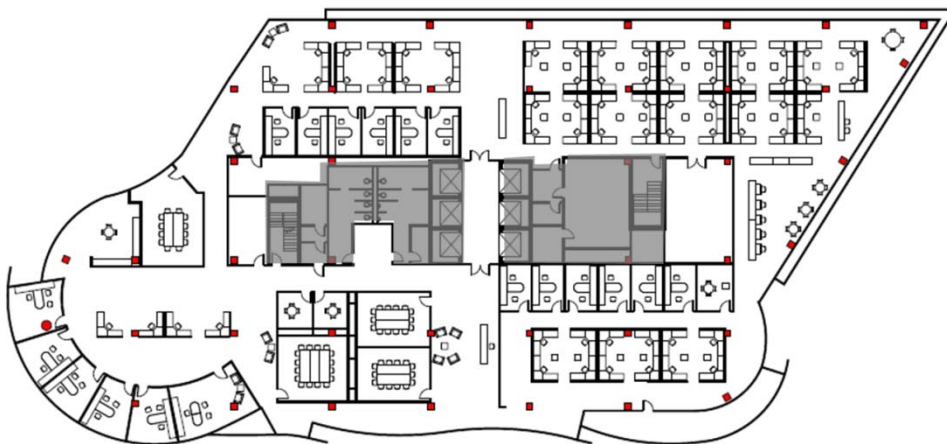

Figure 46: Thesis Level 10 Redesign Plan

## **Building Envelope Study**

### **Existing Glass Façade Study**

The façade system on 800 North Glebe is primarily composed of a glass curtain wall. Since the function of the building is an office, increased day lighting is important for worker productivity. The existing curtain wall system is a stick built system of insulating Viracon VRE glazing with aluminum mullions attached with anchors at each level. The largest insulating glass unit for vision glass on the building is 7'-7 ¼" x 5'-0" composed of ¼" clear Heat Strengthened exterior and interior ply with Low-E coating on the #2 surface, and a ½" air space. Figure 47 is a brief diagram of an insulating glass unit. VRE glazing offers a thin layer of Low-E coating, which offers a good balance between solar energy control and light control, seen in Figure 48.

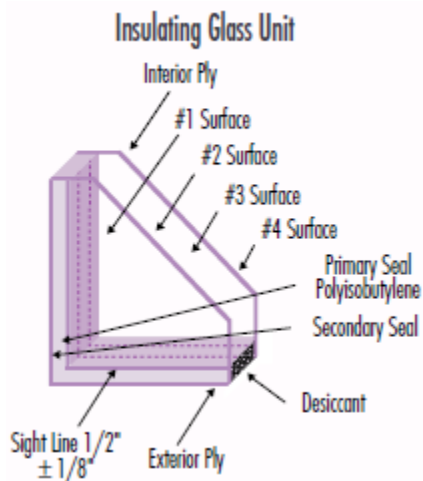

Figure 47: IGU Illustration

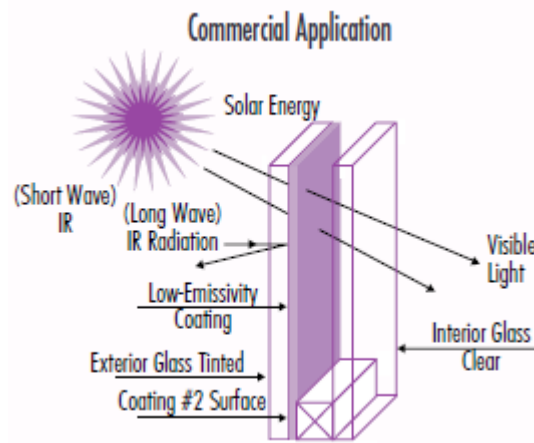

Figure 48: Low-E Affects

Load resistance and deflection were calculated for the glazing based upon previous wind forces calculations. The maximum wind load was 12.44 psf, found at the tenth level. These values were then compared to the allowable values from the manufacturer to determine if the glazing was satisfactory. The aluminum mullions were analyzed to determine their maximum deflection and the load that would be applied to an anchor.

### **Modification Recommendations and System Detailing**

Current glazing panels for 800 North Glebe was determined to be satisfactory for load resistance and deflection. The connections of the glazing to the mullions were then detailed based on manufacturer specification and ASTM E1300, as seen in Figure 49 below. Anchors were then chosen to support the given load and their movement flexibility. The anchor chosen was a Halfen Anchoring System HCWL1/HCWR1 adjustable curtain wall clip. Detailed information and calculations on the materials of the curtain wall system can be found in Appendix F.

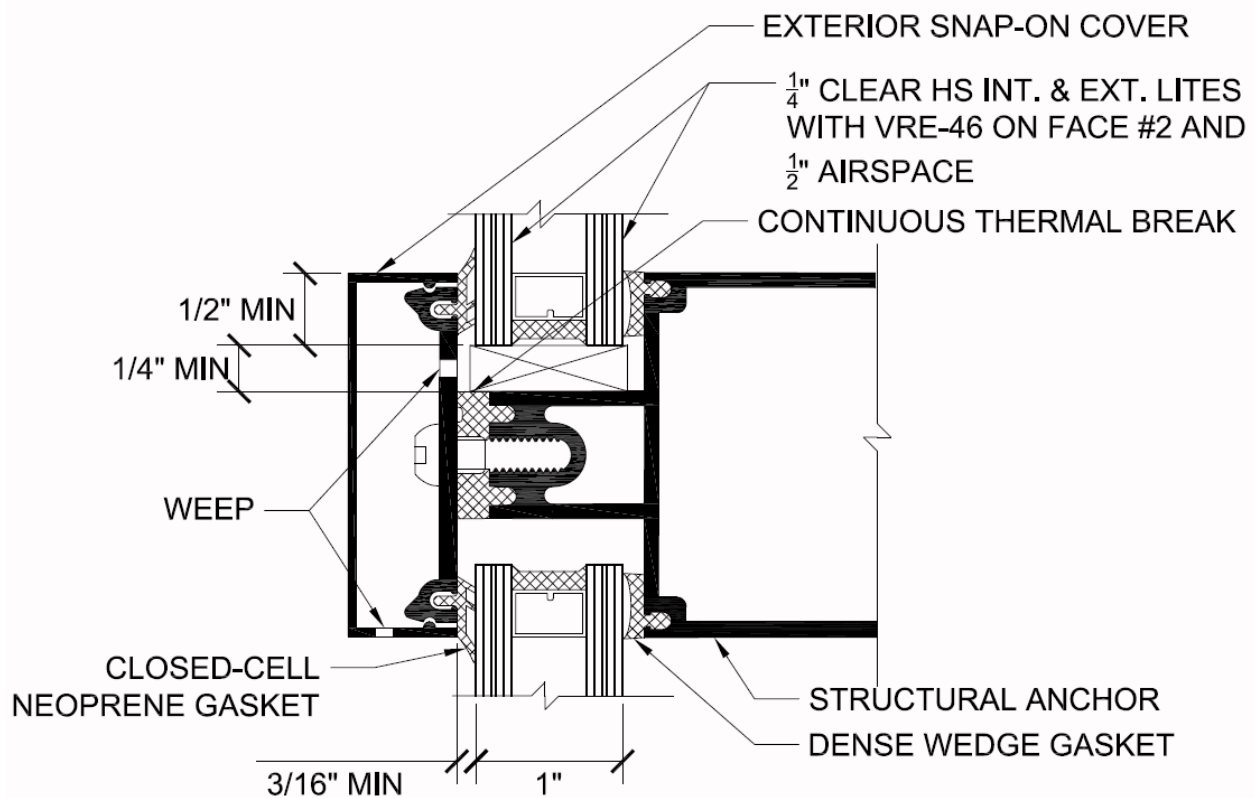

Figure 49: Window Mullion Detail

## **Construction Management Breadth**

The objective of the construction management breadth is to compare a sequencing study and cost analysis the existing design and thesis design for 800 North Glebe. A well designed structure is concerned with resisting all applicable loads while having a constructible building that is cost effective. Changing the slab system to a building wide uniform system will have significant changes on the construction process. The management of the construction site would require a new schedule to allow for more post-tensioning equipment and the timing of the contractors and inspections. Since there was no detailed construction information on the current building system, both the existing and thesis design's construction studies were created.

Only the reinforced concrete structure system was used in the analysis and comparison. Concrete take-offs were performed for both systems, which included concrete, reinforcing and forming. The rest of the construction sequencing and cost, including façade and interior systems, was assumed to remain the same for both designs, and therefore did not contribute to the construction sequencing and cost studies.

## **Sequencing Study**

It had been anticipated that changing the slab-beam system construction from partial post-tensioned design to full post-tensioned design would greatly impact the superstructure schedule. Microsoft Project was used to create schedules for direct comparison of both designs. An arbitrary start date of March 8, 2010 was assumed, because there has yet to be one specified by the owner. Assumptions for the sequencing study include:

- 300 Cubic Yards (CY) daily maximum concrete pours
- 40 hour work week, Monday through Friday
- Portions of the sublevel parking garage structure, shared between 800 and 900 North Glebe was previously constructed due to economical and logistical reasons
- Tendon may not be stressed until 2 days after concrete was poured





## **Cost Study**

Cost is as important measure of the success for a project. A design that keeps the cost relatively low is preferred by the owner, which may lead to repeat client work. Cost comparisons were created for both the existing and thesis structure design. These cost analysis were performed using *RS Means 2009 Construction Cost Data* based upon material unit quantity take-offs. Tables 25 display a summary of the material take-offs for 800 North Glebe’s structure, while a more detailed list can be found in Appendix H.

<b>System</b>	<b>Material</b>	<b>Units</b>	<b>Existing Building</b>	<b>Thesis Building</b>
<b>Slab</b>	<b>Structural Concrete</b>	<b>Cubic Yards</b>	8600	7400
	<b>Rebar</b>	<b>Tons</b>	138	165
	<b>Tendons</b>	<b>Pounds</b>	NA	332800
<b>Beams</b>	<b>Structural Concrete</b>	<b>Cubic Yards</b>	1730	NA
	<b>Rebar</b>	<b>Tons</b>	123	NA
	<b>Tendons</b>	<b>Pounds</b>	130600	NA
<b>Columns</b>	<b>Structural Concrete</b>	<b>Cubic Yards</b>	2060	2550
	<b>Rebar</b>	<b>Tons</b>	107	131
<b>Foundations</b>	<b>Structural Concrete</b>	<b>Cubic Yards</b>	860	880
	<b>Rebar</b>	<b>Tons</b>	32	31

Table 25: Material Take-off Summary

In order to perform an accurate cost analysis comparison, a few assumptions needed to be made and they include:

- 10% overhead and profit used for analysis
- 2009 labor costs used in study
- Both systems to be built with the sublevel already constructed
- Concrete would be placed by pump



### Existing Building Analysis

The total estimated cost of the existing structural design was \$10.3 million. A detailed cost breakdown for the existing structure may be found in Appendix H, while Table 26 shows a summary.

	Ext. Mat.	Ext. Labor	Ext. Equip.	Ext. Total	Ext. Mat. O&P	Ext. Labor O&P	Ext. Equip. O&P	Ext. Total O&P	Total
Concrete	\$ 1,535,010.49	\$ -	\$ -	\$ 1,535,010.49	\$ 1,686,292.28	\$ -	\$ -	\$ 1,686,292.28	\$ 3,221,302.77
Placing	\$ -	\$ 159,626.46	\$ 73,546.10	\$ 233,172.56	\$ -	\$ 246,264.96	\$ 81,030.26	\$ 327,295.22	\$ 560,467.78
Finishing	\$ -	\$ 106,267.00	\$ -	\$ 106,267.00	\$ -	\$ 154,846.20	\$ -	\$ 154,846.20	\$ 261,113.20
Forms	\$ 611,789.60	\$ 1,508,804.20	\$ -	\$ 2,120,593.80	\$ 674,879.10	\$ 2,338,092.70	\$ -	\$ 3,012,971.80	\$ 5,133,565.60
Reinforcement	\$ 351,817.06	\$ 1,185.56	\$ -	\$ 353,002.62	\$ 386,391.24	\$ 1,937.46	\$ -	\$ 388,328.70	\$ 741,331.32
Post-tensioning	\$ 82,260.36	\$ 87,483.24	\$ 2,611.44	\$ 172,355.04	\$ 90,094.68	\$ 142,323.48	\$ 2,611.44	\$ 235,029.60	\$ 407,384.64
	\$ 2,580,877.51	\$ 1,863,366.46	\$ 76,157.54	\$ 4,520,401.51	\$ 2,837,657.30	\$ 2,883,464.80	\$ 83,641.70	\$ 5,804,763.80	\$ 10,325,165.31

Table 26: Existing Building Cost Summary

### Thesis Design Analysis

Total cost for the thesis redesign structure was estimated to be \$11.0 million. The increase in cost for the new system is heavily based upon the amount of labor need for post-tensioning. The detailed thesis redesign cost breakdown is located in Appendix H and Table 27 is a brief summary.

	Ext. Mat.	Ext. Labor	Ext. Equip.	Ext. Total	Ext. Mat. O&P	Ext. Labor O&P	Ext. Equip. O&P	Ext. Total O&P	Total
Concrete	\$ 2,057,650.71	\$ -	\$ -	\$ 2,057,650.71	\$ 2,265,231.69	\$ -	\$ -	\$ 2,265,231.69	\$ 4,322,882.40
Placing	\$ -	\$ 140,595.26	\$ 64,728.48	\$ 205,323.74	\$ -	\$ 216,727.77	\$ 71,320.78	\$ 288,048.55	\$ 493,372.29
Finishing	\$ -	\$ 106,267.00	\$ -	\$ 106,267.00	\$ -	\$ 154,846.20	\$ -	\$ 154,846.20	\$ 261,113.20
Forms	\$ 528,996.27	\$ 1,299,878.79	\$ -	\$ 1,828,875.06	\$ 583,930.53	\$ 2,012,747.52	\$ -	\$ 2,596,678.05	\$ 4,425,553.11
Reinforcement	\$ 221,492.70	\$ 1,185.56	\$ -	\$ 222,678.26	\$ 243,260.44	\$ 1,937.46	\$ -	\$ 245,197.90	\$ 467,876.16
Post-tensioning	\$ 209,664.00	\$ 222,976.00	\$ 6,656.00	\$ 439,296.00	\$ 229,632.00	\$ 362,752.00	\$ 6,656.00	\$ 599,040.00	\$ 1,038,336.00
	\$ 3,017,803.68	\$ 1,770,902.61	\$ 71,384.48	\$ 4,860,090.77	\$ 3,322,054.66	\$ 2,749,010.95	\$ 77,976.78	\$ 6,149,042.39	\$ 11,009,133.16

Table 27: Thesis Redesign Cost Summary

## **Construction Management Conclusion**

Construction time was increased by approximately 120% and the cost was 7% higher for the post-tensioned system. Table 28 was created to show the comparison values for the existing and thesis designs. Post-tensioning increases construction time by double the original design. The primary reason for this increase was because of the wait time between pouring a slab and stressing the tendons. During this wait time, the contractor is able to beginning forming and continues with other duties that were not taken into account in the construction sequence. Based upon the aforementioned sequencing and cost analysis comparison, the thesis structural redesign is not the optimal system.

	<b>Existing Structural System</b>	<b>Thesis Structural System</b>	<b>% Incease</b>
<b>Cost</b>	\$10.3 Million	\$11.0 Million	7%
<b>Time</b>	43 Day	94 Days	118%

Table 28: Construction Comparison

## **Final Conclusion and Recommendations**

Post-tensioning is one of many different slabs systems that could have been implemented into the new column redesign. A post-tensioning system was chosen for various reasons, which include:

- If a significant part of the load is resisted by post-tensioning, non-prestressed reinforcement can be simplified and standardized to a larger degree
- Material handling is reduced since the total tonnage of steel (non-prestressed + prestressed) and concrete is less than for a R.C. floor
- Allows earlier stripping of formwork
- Most of the permanent loads are balanced by post-tensioning, thus considerably reduces tensile forces and deflection which cause increased cracked
- Reduction in slab thickness, and in turn floor weight and material consumption

The bay sizes were reduced from a 30'-0"x46'-0" grid to a 30'-0"x23'-0" grid, thus increasing the total column quantity. The column sizes were reduced on the upper seven levels from 30"x30" to 24"x24". Column grids matched one another on the superstructure levels, but the interface to the below level parking garage required sloping a row of columns on the first level and adding a corbel-transfer beam system on the first sublevel. Also, changing the column grid unquestionably affected the architectural floor plans of the building. The existing layout was studied to determine the proper size of rentable offices and cubicles and great effort was made to keep the same ratios. So as to not diminish the number of offices available, interior partition walls being moved around were kept to as minimal as possible.

The construction management sequencing and cost analysis of the structural system for both the existing design and the thesis redesign concluded that the original design was more cost effective. Because 800 North Glebe is a spec office building, immediate revenue upon completion is a primary concern. The thesis system was concluded to take more time and be more costly; 51 more days to complete and costing nearly 6% greater.

Based upon all of the information from the thesis work, it has been concluded that the original design is a more efficient system. The minimal gains that accompany the structural behavior do not outweigh the time and cost implications of the proposed system.

## **Bibliography**

- American Concrete Institute, 2008, *Building Code Requirements for Structural Concrete and Commentary*, ACI 318-08, Farmington Hills, MI
- American Institute of Steel Construction, Inc., 2005, *Steel Construction Manual*, 13<sup>th</sup> Edition, Chicago, IL
- American Society of Civil Engineers, 2005, *Minimum Design Loads for Buildings and Other Structures*, ASCE 7-05, Reston, VA
- Han, S.W., Kee, S.H., Park, Y.-M., Lee, L.-H., Kang, H.-K., 2006, *Hysteretic behavior of exterior post-tensioned flat plate connections*
- Kang, T.-H., Kee, S.H., Han, S.W., Lee, L.H., Wallace, J.W., 2006, "Interior Post-Tensioned Slab-Column Connections Subjected to Cyclic Lateral Loading", Paper No. 285, *Proceedings of the 8<sup>th</sup> National Conference on Earthquake Engineering*
- Khan, S; Williams, S, 1995, *Post-Tensioned Concrete Floors*, Butterworth-Heinemann, Oxford, Great Britain
- Nilson, A; Darwin, D. and Dolan, C., 2004, *Design of Concrete Structures*, 13<sup>th</sup> Edition, McGraw Hill, New York, NY
- Precast/ Prestressed Concrete Institute, 1999, *PCI Design Handbook*, 6<sup>th</sup> Edition, Chicago, IL
- RSMeans, 2009, *Assemblies Cost Data*, 34<sup>th</sup> Edition, Reed Construction Data, Kinston, MA
- Boonyapinyo, V., Warnitchai, P., and Intaboot, N., 2006, *Seismic capacity evaluation of post-tensioned concrete slab-column frame buildings for pushover analysis*

## **Appendix A: List of Figures**

Figure 1: Floor Level 3 .....	8
Figure 2: Floor level 5.....	8
Figure 3: Floor level 8.....	8
Figure 4: Floor level 10.....	8
Figure 5: South-East Facade.....	9
Figure 6: Sail Feature .....	9
Figure 7: Front View.....	10
Figure 8: Canopy Over Main Entrance .....	10
Figure 9: Slab Type Layout .....	12
Figure 10: Shear Wall Location .....	13
Figure 11: Lateral System Alternative.....	14
Figure 12: Slab Systems .....	17
Figure 13: Post-tensioned Girder.....	17
Figure 14: One-way Slab Strip.....	17
Figure 15: Initial Wind Load Determination .....	18
Figure 16: Shear Wall vs. Entire Structure .....	19
Figure 17: Current Column Layout.....	26
Figure 18: New Column Layout.....	26
Figure 19: Lower 6 Levels Distributed Tendon Layout .....	28
Figure 20: Upper 4 Levels Distributed Tendon Layout .....	28
Figure 21: Lower 6 Levels Banded Tendon Layout .....	29
Figure 22: Upper 4 Levels Banded Tendon Layout .....	30
Figure 23: Anchorage Zones .....	31
Figure 24: Anchorage Zone Plan and Elevation View .....	32
Figure 25: Actual Anchorage Image.....	32
Figure 26: Tendon Layout Plan Around Column.....	33
Figure 27: Section A-A.....	33
Figure 28: Two-way Slab Deflection .....	34
Figure 29: Lower Level Deflection Contour Plan .....	35
Figure 30: Wind Case Visual Representation.....	38
Figure 31: North-South Wind Loads .....	42
Figure 32: East-West Wind Loads .....	42
Figure 33: North-South Building Loads.....	46
Figure 34: East-West Seismic Building Loads.....	47
Figure 35: ETABS Model.....	50

Figure 36: COM vs. COR .....	51
Figure 37: Standard Interior Column .....	56
Figure 38: Typical Column Reinforcing Plan and Section .....	58
Figure 39: Sloped Column Plan .....	59
Figure 40: Sloped Column Reinforcing.....	59
Figure 41: Existing Level 3 Plan .....	63
Figure 42: Thesis Level 3 Redesign Plan.....	63
Figure 43: Existing Level 5 Plan .....	64
Figure 44: Thesis Level 5 Redesign Plan.....	64
Figure 45: Existing Level 8 Plan .....	65
Figure 46: Thesis Level 8 Redesign Plan.....	65
Figure 47: Existing Level 10 Plan .....	66
Figure 48: Thesis Level 10 Redesign Plan.....	66
Figure 49: IGU Illustration                      Figure 50: Low-E Affects.....	67
Figure 51: Window Mullion Detail .....	68
Figure 52: Existing Building Schedule .....	70
Figure 53: Thesis Redesign Schedule .....	71

## **Appendix B: List of Tables**

Table 1: Live Loads .....	24
Table 2: Dead loads.....	25
Table 3: Deflection Verification .....	35
Table 4: Load Combination Check .....	36
Table 5: Wind Case Determination.....	37
Table 6: Wind Load Variables .....	39
Table 7: North-South Wind Load Forces.....	40
Table 8: East-West Wind Load forces .....	41
Table 9: Horizontal Irregularity Check .....	43
Table 10: Vertical Irregularity Check.....	44
Table 11: Modal Periods of Vibration .....	44
Table 12: Seismic Design Variables.....	45
Table 13: North-South Seismic Forces .....	46
Table 14: East-West Seismic Forces.....	47
Table 15: Eccentricity Determination .....	51
Table 16: Torsional Moment.....	52
Table 17: Max Point Displacement .....	54
Table 18: Uncorrected Interstory Drifts.....	55
Table 19: Corrected Interstory Drifts.....	55
Table 20: Column Axial Loads .....	56
Table 21: Column Axial and Moment Loads .....	57
Table 22: Column Sizing.....	57
Table 23: Overturning Moment .....	60
Table 24: Office Layout Count .....	62
Table 25: Material Take-off Summary .....	72
Table 26: Existing Building Cost Summary.....	73
Table 27: Thesis Redesign Cost Summary.....	73
Table 28: Construction Comparison .....	74

## Appendix C: Slab Design

CHAP 18	1/3
<p>18.1.: Conform to 3.5.6</p> <p>18.2.: General design concerning all possible loading</p> <p>18.3.: DESIGN ASSUMPTIONS</p> <p>→ 18.3.1.: strength design for flex &amp; axial conform to 18.2</p> <p>18.3.2.: elastic theory shall be used</p> <p>→ 18.3.2.1.: strains vary linearly w/ depth thru entire ld range</p> <p>18.3.2.2.: @ cracked sections, conc resists no tension</p> <p>* → 18.3.3.: classify 2-way slab as Class U</p> <ul style="list-style-type: none"> <li>• <math>f_t \leq 6\sqrt{f'_c}</math> for 318-08</li> <li>• <math>f_t \leq 7.5\sqrt{f'_c}</math> for Concept of 318-05</li> </ul> <p>→ 18.3.4.: For Class U, stresses @ service permitted to be done w/ uncracked section</p> <p>→ 18.3.5.: deflect in accordance w/ 9.5.4</p> <p>→ 9.5.4.: For Class U, use <math>F_y</math></p> <ul style="list-style-type: none"> <li>: consider long-term deflection w/ creep &amp; shrinkage</li> <li>: shall not exceed Table 9.5(b)</li> </ul> <p>outer bays { → <math>l/480</math> unless adequate measure are taken</p> <p>inter. bays → <math>l/240</math> considering time-deflection characteristics</p> <p>→ <math>l/360</math> of immediate live load</p> <p>18.4.: Serviceability - Flexural</p> <p>→ 18.4.1.: stresses in conc immediately after transfer</p> <ul style="list-style-type: none"> <li>a) extreme fiber stress <math>\leq 0.6 f'_c</math></li> <li>b) where <math>f_t \geq 6\sqrt{f'_c}</math> additional reinf shall be added</li> </ul> <p>→ total force in tensile zone of <math>0.6 F_y</math></p> <p>→ 18.4.2.: stress in conc @ service shall not exceed</p> <ul style="list-style-type: none"> <li>a) <math>0.45 f'_c</math> for prestress plus sustained load</li> <li>b) <math>0.6 f'_c</math> for prestress plus total load</li> </ul> <p>→ 18.4.4.2.: max spacing of reinf <math>\Rightarrow s = 15 \left( \frac{40000}{A_{ps}} \right) - 2.5c</math></p> <p style="margin-left: 100px;"><math>= 12 \left( \frac{40000}{A_{ps}} \right)</math></p> <p style="margin-left: 100px;"><math>\approx 18"</math></p>	



2/3

18.5: permissible stresses

→ 18.5.1: tensile stress shall not exceed  $0.7F_{pu}$  in tendons @ anchorage devices

18.7: Flex strength

→ 18.7.2:  $F_{ps} = F_{se} + 10,000 + \frac{F_c'}{300\rho_p}$  for  $\frac{span}{depth} > 35$

$F_{ps} = F_{se} + 10,000 + \frac{F_c'}{100\rho_p}$  for  $\frac{span}{depth} < 35$

but not greater than  $F_{py}$  ;  $F_{se} + 60,000$  < 35  
 $F_{se} + 30,000$  > 35

18.9: Min Bonded Reinf

→ 18.9.1:  $A_s = 0.004 A_{cf}$  where  $A_{cf}$  = area of cross section b/n flex tension ; COG

→ 18.9.2: shall be uniformly distr.

→ 18.9.3.1: not needed in pos mom area where  $f_c \leq 2\sqrt{F_c'}$

pos → 18.9.3.2: where  $f_c > 2\sqrt{F_c'}$   $A_s = \frac{N_c}{0.5F_y}$  ~ tensile force

Neg → 18.9.3.3: @ col  $A_s = 0.0075 A_{cf}$  ~ gross Area in 2 orthog equiv. frames intersecting @ column

→ spacing < 12"

→ distributed b/n 1.5h outside opp. faces of col support

→ at least 4 bars in each dir.

pos → 18.9.4.1: min length  $\frac{1}{3} l_n$  on side of support

Neg → 18.9.4.2: min length  $\frac{1}{6} l_n$  on each of support

18.10: Stat. indet structures

→ 18.10.1: use elastic analysis

18.12: Slab System

- 18.12.1: factored moments & shears meet 13.7 (Equiv Frame) or more detailed method
- 18.12.4: tendon spacing  $< 9h$  or 5ft  
 : provide min avg effective prestress of 125psi
- 18.12.5: provide bonded reinf w/ 18.9.3
- 18.12.6: min of 2 tendons in each dir @ columns anchored to longitudinal col. reinf.  
 → place distributed first, then bonded

18.13: Anchorage Zones (pg 297 Figures)

- 18.13.1: Anchorage zones composed of 2 zones
  - 1) local zone
  - 2) general zone
- 18.13.2: local zone design based upon factor prestress force  $P_m$  & req of 9.2.5 & 9.3.2.5
  - 9.2.5: factored load of 1.2 applied to max prestress jack force
  - 9.3.2.5:  $\phi = .85$  for strength reduction
- 18.13.3: general zone reinf provided to resist bursting, spalling & longitudinal edge tension forces induced by anchors
  - 18.13.3.1: based upon factored load  $P_m$  w/ chap reqts  
 $* P_m = (1.2)(0.8)F_{pu} A_{ps} = 0.96 F_{pu} A_{ps}$
- 18.13.4.1: tensile stress @ nominal strength of unbonded prestressing reinf for resisting tensile forces in anchorage zone is limited to  $f_{ps} = f_{se} + 10,000$  1.0
- 18.13.4.2: general zone compressive strength limited to  $.7x f_{ci}$
- 18.13.4.3: Conc. compr. strength @ time of post-tens. must be on doc.  
 → must be at least 4000 psi
- 18.13.5: general zones designed by:
  - a) strut-tie method
  - b) finite elem
  - $T_{burst} = 0.25 E P_{pu} (1 - \frac{h_{genc}}{h})$
  - $d_{burst} = 0.5(h - 2e_{enc})$

	<p><u>Reinf. Provisions ASCE 7 sec 14.2</u></p> <p><u>14.2.2.2: ACI sec 10.5.5</u></p> <p>→ Flex members to have @ least 2 flex bars continuously top &amp; bottom thru beam &amp; developed into columns</p> <p><u>14.2.2.3: ACI sec 11.11.3</u></p> <p>→ Structures in SDC B, w/ clear ht - to - plan dim ratio of 5 or less shall be designed for shear</p> <p>• <math>12.75 \times 12' / 30' = 5.1</math> ✓ OK</p> <p><u>14.2.2.7: Anchorage for unbanded tendons</u></p> <p>→ Not needed b/c not "assigned to intermediate or high seismic design category"</p> <p><u>ACI 318-08</u></p> <p><u>18.12.6: @ least 2 strands thru column &amp; woven in each direction</u></p> <p><u>18.12.7: where not to meet 18.12.6</u></p> <p>→ Bottom Reinf. shall not be below</p> <p>1) <math>(1.5) \frac{3 \sqrt{f_c'} b_w d}{f_y} = (1.5) \frac{(3) \sqrt{8000} (24)(10.5)}{60000} = 1.69 \text{ in}^2</math></p> <p>2) <math>300 \frac{b_w d}{f_y} = \frac{(300)(24)(10.5)}{60000} = 1.26 \text{ in}^2</math></p> <p>→ bottom bars be continuous or Class B splice meet develop length of 12.2.1</p>	
	<p><u>21.3.6</u></p>	<p>2</p>
	<p><u>21.3.6.1: Use load combinations of Eqs 9.5 - 9.7</u></p> <p>Reinf provided to resist <math>M_{seeb}</math> in CS</p> <p><u>21.3.6.2: Reinf in eff width to resist <math>\frac{1}{4} M_{seeb}</math></u></p> <p>* Eff width = <math>1.5h + 1.5h + C_2</math></p> <p><u>21.3.6.3: @ least <math>\frac{1}{2}</math> reinf of CS in Eff Width in accordance w/ 13.5.3.2</u></p>	

	SLAB DEFL	1
	$M_{cr} = \frac{F_r I_g}{y_t}$ $M_{cr} = \frac{(630)(5632)}{3.25}$ $M_{cr} = 1012.6 \text{ k-ft}$ $\Delta_D = \frac{.0026 \omega_D l^4}{EI} = \frac{(0.0026)(1.61)(30)^4 (12^3)}{(5098)(5632)} = .203$ $\Delta_L = \frac{.0048 \omega_L l^4}{EI} = \frac{(0.0048)(1.2)(30)^4 (12^3)}{(5098)(5632)} = .281$ $\Delta_{long} = 3.0 [0.203 + (0.25)(.281)] = .819$ $\Delta_L = \frac{(0.0048)(1.2)(22)^4 (12^3)}{(5098)(5632)} = .081$ $\frac{l}{360} = \frac{(30 \times 12)}{360} = 1.0$ $\Delta_{max} = .281 + .081 = .362 < 1.0 \quad \checkmark \text{ OK}$	

2

Code Based  
Slab Deflection:

Outer bays:  $\frac{l}{480} = \frac{(22 \times 12)}{480} = 0.55''$  but can use  $\frac{l}{240}$

Time  $\frac{l}{240} = \frac{(22 \times 12)}{240} = 1.1''$

Live  
Int Bays:  $\frac{l}{360} = \frac{(22 \times 12)}{360} = 0.74''$

- 1) Service LC - (D + Bal) = Immediate live
- 2) Long term LC - (D + Bal) = LT Live

1)  $0.45'' - 0.14'' = 0.31'' < 0.74''$  ✓ OK

2)  $1.2'' - 0.14'' = 1.06'' < 1.10''$  ✓ OK

### Shear Caps

$$V_c = \phi 4\sqrt{f_c'} b_o d$$

$$4\sqrt{6000} (136) (10) = 421 \text{ k} *$$

$$\textcircled{2} \left(2 + \frac{4}{s_c}\right) \sqrt{f_c'} b_o d$$

$$\left(2 + \frac{4}{1}\right) \sqrt{6000} (136) (10) = 632$$

$$\textcircled{3} \left(\frac{\alpha_c}{b_o/d} + 2\right) \sqrt{f_c'} b_o d$$

$$\left(\frac{40}{8.7} + 2\right) \sqrt{6000} (136) (10) = 510 \text{ Inspection}$$

$$\phi V_c = (1.75)(421) = 315 \text{ k}$$

$$V_u = W_u * \text{Area}$$

$$= [(1.2 \times 125) + (1.6 \times 100)] (22 \times 30 - 2.83^2)$$

$$= 202 \text{ k}$$

$$\phi V_c \geq V_u$$

✓ OK

Where  $136'' = 4 \text{ side} * (24'' + \overset{\sim 10''}{d/2} + d/2)$

# Appendix D: Lateral System Design

## Wind Determination Calculations

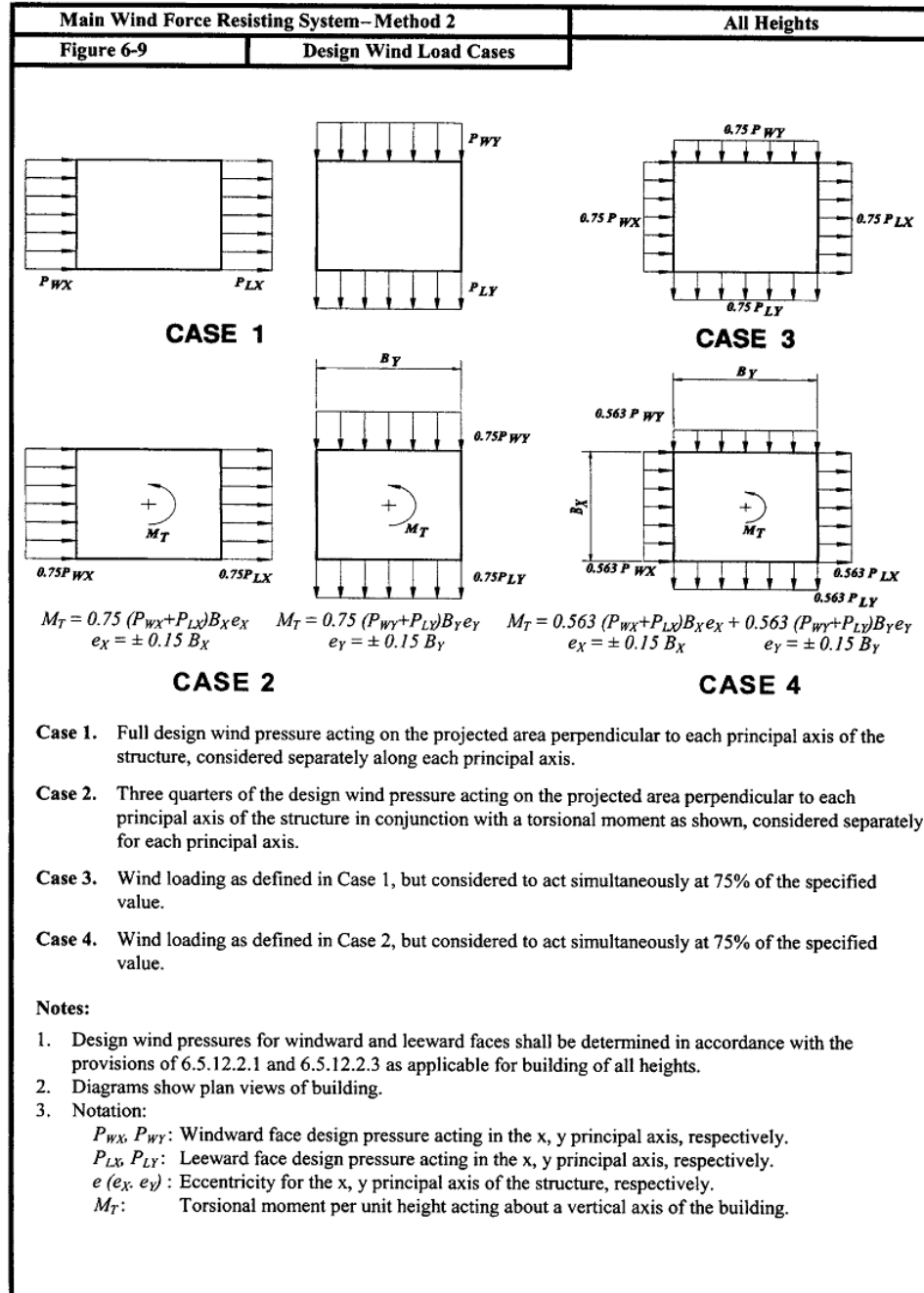

WIND

METHOD 2 ANALYTICAL PROCEDURE OF CHAP 6

SAMPLE CALL @ LEVEL 9 IN N/S DIRECTION

$$K_z = 2.01 \left( \frac{z}{z_g} \right)^{2/7}$$

$$K_{z_9} = 2.01 \left( \frac{107.75}{1200} \right)^{2/7} = 1.01$$

$$q_z = 0.00256 K_z K_{zt} K_d V^2 I$$
$$= (0.00256)(1.01)(1.00)(0.85)(90)^2(1.0) = 17.80$$

$$q_h = 0.00256 K_h K_{zt} K_d V^2 I$$
$$= (0.00256)(1.12)(1.0)(0.85)(90)^2(1.0) = 19.7$$

C17

$$\eta_1 = 100/H = 100/153.75 = .65 \leq 1 \text{ Hz} \therefore \underline{\text{Flexible}}$$

$$g_w = g_v = 3.4$$

$$g_R = \sqrt{2 \ln(3600 \eta_1)} + \frac{0.577}{\sqrt{2 \ln(3600 \eta_1)}}$$
$$= \sqrt{2 \ln(2341.5)} + \frac{0.577}{\sqrt{2 \ln(2341.5)}} = 4.086$$

$$\bar{z} = 0.6h = (0.6)(153.75) = 92.25 > z_{min} \checkmark \text{ OK}$$

$$I_z = C \left( \frac{33}{\bar{z}} \right)^{1/6} = (0.3) \left( \frac{33}{92.25} \right)^{1/6} = 0.253$$

$$L_z = l \left( \frac{\bar{z}}{33} \right)^{\bar{z}} = (320) \left( \frac{92.25}{33} \right)^{1/3} = 450.78$$



$$Q = \sqrt{\frac{1}{\left(1 + 0.63 \left(\frac{B+H}{L_z}\right)^{1.63}\right)}}$$

$$= \sqrt{\frac{1}{1 + 0.63 \left(\frac{202 + 153.75}{450.78}\right)^{1.63}}} = 0.780$$

$V = 90 \text{ mph}$  from Fig 6-1

$$\bar{V}_z = \bar{b} \left(\frac{\bar{z}}{33}\right)^{\bar{\alpha}} V \left(\frac{88}{60}\right) = (0.45) \left(\frac{92.25}{33}\right)^{1.4} (90) \left(\frac{88}{60}\right) = 76.81$$

$$N_i = \frac{n_i L_z}{\bar{V}_z} = \frac{(0.65)(450.78)}{76.81} = 3.82$$

$$R_n = \frac{7.47 N_i}{(1 + 10.3 N_i)^{5/3}} = \frac{(7.47)(3.82)}{(1 + 10.3(3.82))^{5/3}} = 0.0602$$

$$R_h = \frac{1}{\eta} - \frac{1}{2\eta^2} (1 - e^{-2\eta}) \quad \text{where } \eta = 4.6 n_i h / \bar{V}_z$$

$$R_h = 0.153$$

$$R_b = \frac{1}{\eta} - \frac{1}{2\eta^2} (1 - e^{-2\eta}) \quad \text{where } \eta = 4.6 n_i B / \bar{V}_z$$

$$R_b = 0.119$$

$$R_L = \frac{1}{\eta} - \frac{1}{2\eta^2} (1 - e^{-2\eta}) \quad \text{where } \eta = 15.4 n_i L / \bar{V}_z$$

$$R_L = 0.0358$$

z

$$R = \sqrt{\frac{1}{\frac{B}{h}} R_n R_h R_e (.53 + .47 R_L)} = 0.17307$$

.2 for concrete

$$G_s = 0.925 \left[ \frac{1 + 1.7 I_s \sqrt{g_o^2 Q^2 + g_p^2 R^2}}{1 + 1.7 g_v I_s} \right] = 0.81912$$

PRESSURE COEFF:  $C_p$  (FIGURE 6-6)

→ WINDWARD  $C_p = .8$

→ LEEWARD (N/S)  $C_p = -.45$  ✓  $4/B = 1.16$

(E/W)  $C_p = -.5$  w/  $4/B = .86$

VELOCITY PRESSURE EXPOSURE COEFF @ H<sub>e</sub> Z:  $k_z$  (Table 6-5)

$$k_z = [2.01] \left[ \frac{h_z}{1200} \right]^{2/7} = (.62511)(h_z)^{2/7}$$

$$\text{@ level 9: } k_z = (.62511)(107.75)^{2/7} = 1.01$$

VELOCITY PRESSURE @ H<sub>e</sub> Z:  $q_z$  (Eq 6-15)

$$q_z = (.00256)(k_z)(k_{zt})(k_d) V^2 I$$

$$= (.00256)(k_z)(1.0)(.85)(90)^2(1.0) = 17.6256(k_z)$$

$$\text{@ level 9: } q_z = (17.6256)(1.01) = 17.7936 \text{ *kt}^2$$

$$\text{@ MEAN ROOF H<sub>e</sub>: } q_h = (17.6256)(1.11747) = 19.6961 \text{ *kt}^2$$

PRESSURES:  $p_z$  &  $p_h$  (Eq 6-19)

$$p_z = q_z G_f C_p - q_h (G C_{pi}) \quad \text{WINDWARD}$$

$$p_h = q_h G_s C_p - q_h (G C_{pi}) \quad \text{LEEWARD}$$

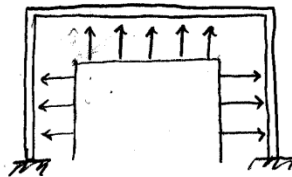

\* INTERNAL PRESSURES CANCEL

N/S:  $W_w \Rightarrow p_z = q_z (1.8191)(.8) = \boxed{.6553 q_z}$

$L_w \Rightarrow p_h = (19.7)(1.8191)(-.45) = \boxed{-7.26 \text{ psf}}$

E/W:  $W_w \Rightarrow p_z = q_z (1.8175)(.8) = \boxed{.654 q_z}$

$L_w \Rightarrow p_h = (19.7)(.8175)(-.5) = \boxed{-8.05 \text{ psf}}$

FORCES OF WINDWARD PRESSURE (kips):

@ level 9 (N/S):  $\frac{2.15}{1000} \left[ (11.66 \text{ psf}) \left( \frac{13.75'}{2} \right) + (11.25) \left( \frac{12.75'}{2} \right) \right]$

$\Rightarrow (2.15) [80.16 + 71.72] = \boxed{32.65 \text{ k}}$

STORY SHEAR (kips):

@ level 9 (N/S): sum level forces above

$\Rightarrow (24.75) + (42.58) + (35.07) = \boxed{102.4 \text{ k}}$

**Seismic Determination Calculations**

	SEISMIC		1
	$I = 1.0$ $S_s = 0.197$ $S_1 = 0.063$	$F_A = 1.6$ $F_v = 2.4$	$T_c = 6s$
	<u>X-Dir</u> $R = 5$ bldg frame ORSW $C_d = 4.5$ $C_u = 0.02$ $h_n = 153.75'$ $X = .75$ $C_u = 1.7$	<u>Y-Dir</u> $R = 5.5$ Dual System ORSW $C_d = 4.5$ $C_u = 0.02$ $h_n = 153.75'$ $X = .75$ $C_u = 1.7$	
	$W = 49554^k$		
	$T_x = 3.404^s$ $T_y = 1.104^s$ $T_z = 1.9734^s$		
	<u>Story Shears in X-Dir</u> $S_{ps} = \frac{2}{3} F_A S_s = (\frac{2}{3})(1.6)(0.197) = 0.2101$ $S_{D1} = \frac{2}{3} F_v S_1 = (\frac{2}{3})(2.4)(0.063) = 0.1008$ $I = 1.0$ $T_a = 0.873$ $C_u = 1.7$ $T \leq \begin{cases} C_u T_a = 1.4841^s * \text{Goums} \\ T_x = 3.404^s \end{cases}$ $C_s = \begin{cases} S_{ps} / (1/2) = 0.042 \\ S_{D1} / (T R / 2) = 0.01358 * \text{Controls} \\ \text{min } S_{D1} T_c / (T^2 R / I) = 0.0549^s * \text{Controls} \end{cases}$ $V_b = C_s W = 679$		

3] Torsion Ampl Factor

74  
69

X-Dir

$$S_{max} = 3.2638$$

$$S_{avg} = \frac{3.2638 + 2.7882}{2} = 3.026$$

$$A_x = \left[ \frac{S_{max}}{1.2 S_{avg}} \right]^2 = \left[ \frac{3.2638}{(1.2)(3.026)} \right]^2 = .8077 < 1.0$$

Y-Dir

$$S_{max} = .5668$$

$$S_{avg} = \frac{.4848 + .3129}{2} = .4014$$

$$A_x = \left[ \frac{S_{max}}{1.2 S_{avg}} \right]^2 = \left[ \frac{.5668}{(1.2)(.4014)} \right]^2 = 1.385 > 1.0$$

But by 12.8.4.3, seismic design category B does not need  $A_x$

Permitted Analysis

$$T_s = \frac{S_{ol}}{S_{os}} = \frac{.1008}{.191} = .528$$

$$3.5 T_s = 1.86 > T_x$$

→ per Table 12.3-2 ⇒ No Vert Irreg

→ Torsional Irreg

X-Dir  
 $\text{drift}_{max} = .002558$

Y-Dir  
 $\text{drift}_{max} = .000434$

$$\text{drift}_{avg} = .002095$$

$$\text{drift}_{avg} = .000363$$

$$X = \frac{.002558}{.002095} = 1.221$$

$$Y = \frac{.000434}{.000363} = 1.196$$

∴ Torsional Irregular in both dir  
 12.7.3 → 3D w/ 3DOF & cracked sections

Correction to Displ

X-Dir

$$\frac{C_u T_u}{T_x} = \frac{1.485}{3.409} = .34$$

Y-Dir

$$\frac{C_u T_u}{T_y} = \frac{1.485}{1.101} = 1.42$$

Displ Correction:  $\delta_x = \frac{C_u S_{ue}}{I}$

X-Dir  $\Rightarrow \frac{(4.5)(.002558)}{1.0} = .0115 < .02$

Y-Dir  $\Rightarrow \frac{(4.5)(.000434)}{1.0} = .002 < .02$

Ss	0.179		Fa	1.6	#levels	11
S1	0.063		Fv	2.4	f-f	0
I	1.000				Bx	250.00
Occ.	II		TL	8.0	By	215.00
SDC	B					
<b>X-Dir</b>			<b>Y-Dir</b>			
R	5		R	5.5		
Cd	4.5		Cd	4.5		
Ct	0.02		Ct	0.02		
h	153.8		h	153.8		
x	0.75		x	0.75		
Cu	1.7		Cu	1.7		
SDS	0.1909		SDS	0.1909		$2/3 * Fa * Ss$
SD1	0.1008		SD1	0.1008		$2/3 * Fv * S1$
Ta	0.873		Ta	0.873		$Ct * h^x$
Tb	3.4040		Tb	1.101		ETABS
T= min	1.4845		T= min	1.4845		Cu * Ta
	3.404			1.101		Tb
Cs=min	0.0382		Cs=min	0.0347		SDS / (R/I)
	0.013580016			0.016639979		SD1 / (T(R/I))
	0.073181279			0.120864201		SD1 * TL / (T^2(R/I))
W	49641.8373		W	49641.8373		
Vb	674.1369227		Vb	826.0391237		
k	1.492267191					

			T=	1.484534			
			k=	1.49			
			Vb=	674.1369			
<b>X-Direction</b>							
Level (i)	Story Height (h <sub>i</sub> )	Height Above Ground (h)	Story Weight (w (kips))	w*h <sub>k</sub>	C <sub>vx</sub>	Lateral Story force (f <sub>i</sub> )	Story Shear (V <sub>i</sub> )
PHR	18.5	153.75	524.51	961755.3	0.03	19.72	19.72
Roof	13.75	135.25	4181.11	6331661	0.19	129.81	149.53
10	13.75	121.5	4355.72	5620890	0.17	115.24	264.77
9	12.75	107.75	4342.48	4684330	0.14	96.04	360.81
8	12.75	95	4350.33	3888786	0.12	79.73	440.54
7	12.75	82.25	4546.41	3277650	0.10	67.20	507.74
6	12.75	69.5	5344.45	2996653	0.09	61.44	569.18
5	12.75	56.75	5321.16	2204916	0.07	45.21	614.38
4	12.75	44	5459.97	1547608	0.05	31.73	646.11
3	12.75	31.25	5354.67	910853.5	0.03	18.67	664.79
2	18.5	18.5	5861.03	455966.4	0.01	9.35	674.14
			49641.8373	32881069			
Level (i)	Story Height (h <sub>i</sub> )	Height Above Ground (h)	B <sub>y</sub>	5%B <sub>y</sub>	A <sub>x</sub>	M <sub>x</sub> (ft-k)	M <sub>x</sub> (in-k)
PHR	18.5	153.75	215	10.75	1.0	212	2543.6
Roof	13.75	135.25	215	10.75	1.0	1395	16745.9
10	13.75	121.5	215	10.75	1.0	1239	14866.1
9	12.75	107.75	215	10.75	1.0	1032	12389.1
8	12.75	95	215	10.75	1.0	857	10285.0
7	12.75	82.25	215	10.75	1.0	722	8668.7
6	12.75	69.5	215	10.75	1.0	660	7925.5
5	12.75	56.75	215	10.75	1.0	486	5831.5
4	12.75	44	215	10.75	1.0	341	4093.1
3	12.75	31.25	215	10.75	1.0	201	2409.0
2	18.5	18.5	215	10.75	1.0	100	1205.9
							86963.7



			T=	1.1014			
			k=	1.49			
			Vb=	826.0391			
Y-Direction							
Level (i)	Story Height (h <sub>i</sub> )	Height Above Ground (h)	Story Weight (w (kips))	w*h <sub>k</sub>	C <sub>vx</sub>	Lateral Story force (f <sub>i</sub> )	Story Shear (V <sub>i</sub> )
PHR	18.5	153.75	524.51	961755.3	0.03	24.16	24.16
Roof	13.75	135.25	4181.11	6331661	0.19	159.06	183.23
10	13.75	121.5	4355.72	5620890	0.17	141.21	324.43
9	12.75	107.75	4342.48	4684330	0.14	117.68	442.11
8	12.75	95	4350.33	3888786	0.12	97.69	539.81
7	12.75	82.25	4546.41	3277650	0.10	82.34	622.15
6	12.75	69.5	5344.45	2996653	0.09	75.28	697.43
5	12.75	56.75	5321.16	2204916	0.07	55.39	752.82
4	12.75	44	5459.97	1547608	0.05	38.88	791.70
3	12.75	31.25	5354.67	910853.5	0.03	22.88	814.58
2	18.5	18.5	5861.03	455966.4	0.01	11.45	826.04
			49641.84	32881069			
Level (i)	Story Height (h <sub>i</sub> )	Height Above Ground (h)	B <sub>y</sub>	5%B <sub>y</sub>	A <sub>x</sub>	M <sub>z</sub> (ft-k)	M <sub>z</sub> (in-k)
PHR	18.5	153.75	250	12.5	1.0	302	3624.2
Roof	13.75	135.25	250	12.5	1.0	1988	23859.6
10	13.75	121.5	250	12.5	1.0	1765	21181.2
9	12.75	107.75	250	12.5	1.0	1471	17652.0
8	12.75	95	250	12.5	1.0	1221	14654.1
7	12.75	82.25	250	12.5	1.0	1029	12351.2
6	12.75	69.5	250	12.5	1.0	941	11292.3
5	12.75	56.75	250	12.5	1.0	692	8308.8
4	12.75	44	250	12.5	1.0	486	5831.9
3	12.75	31.25	250	12.5	1.0	286	3432.4
2	18.5	18.5	250	12.5	1.0	143	1718.2
							123905.9

**Story Drift and Displacement**

Story	Item	Load	DriftX	DriftY
MAIN ROOF	Max Drift X	COMB1X	0.001977	
MAIN ROOF	Max Drift Y	COMB1Y		0.000288
MAIN ROOF	Max Drift X	COMB2EX	0.001856	
MAIN ROOF	Max Drift Y	COMB2EY		0.000266
10TH	Max Drift X	COMB1X	0.002117	
10TH	Max Drift Y	COMB1Y		0.000321
10TH	Max Drift X	COMB2EX	0.002009	
10TH	Max Drift Y	COMB2EY		0.000342
9TH	Max Drift X	COMB1X	0.002275	
9TH	Max Drift Y	COMB1Y		0.000325
9TH	Max Drift X	COMB2EX	0.002186	
9TH	Max Drift Y	COMB2EY		0.0004
8TH	Max Drift X	COMB1X	0.002415	
8TH	Max Drift Y	COMB1Y		0.000327
8TH	Max Drift X	COMB2EX	0.00234	
8TH	Max Drift Y	COMB2EY		0.000445
7TH	Max Drift X	COMB1X	0.002491	
7TH	Max Drift Y	COMB1Y		0.000326
7TH	Max Drift X	COMB2EX	0.002423	
7TH	Max Drift Y	COMB2EY		0.000471
6TH	Max Drift X	COMB1X	0.002498	
6TH	Max Drift Y	COMB1Y		0.000329
6TH	Max Drift X	COMB2EX	0.002437	
6TH	Max Drift Y	COMB2EY		0.000461
5TH	Max Drift X	COMB1X	0.002364	
5TH	Max Drift Y	COMB1Y		0.000306
5TH	Max Drift X	COMB2EX	0.002308	
5TH	Max Drift Y	COMB2EY		0.000464
4TH	Max Drift X	COMB1X	0.002089	
4TH	Max Drift Y	COMB1Y		0.000263
4TH	Max Drift X	COMB2EX	0.002039	
4TH	Max Drift Y	COMB2EY		0.000448
3RD	Max Drift X	COMB1X	0.001635	
3RD	Max Drift Y	COMB1Y		0.000216
3RD	Max Drift X	COMB2EX	0.001599	
3RD	Max Drift Y	COMB2EY		0.000409
2ND	Max Drift X	COMB1X	0.000861	
2ND	Max Drift Y	COMB1Y		0.000084
2ND	Max Drift X	COMB2EX	0.000739	
2ND	Max Drift Y	COMB2EY		0.00029

\*Uncorrected values\*

## **Appendix E: Column Design**

**(This page was left Blank intentionally)**

Material Properties:

```

=====
f'c = 6 ksi          fy = 60 ksi
Ec = 4415.21 ksi    Es = 29000 ksi
Ultimate strain = 0.003 in/in
Beta1 = 0.75
  
```

Section:

```

=====
Rectangular: Width = 24 in      Depth = 24 in

Gross section area, Ag = 576 in^2
Ix = 27648 in^4                Iy = 27648 in^4
Xo = 0 in                      Yo = 0 in
  
```

Reinforcement:

```

=====
Bar Set: ASTM A615
Size Diam (in) Area (in^2)  Size Diam (in) Area (in^2)  Size Diam (in) Area (in^2)
-----
# 3      0.38      0.11  # 4      0.50      0.20  # 5      0.63      0.31
# 6      0.75      0.44  # 7      0.88      0.60  # 8      1.00      0.79
# 9      1.13      1.00  # 10     1.27      1.27  # 11     1.41      1.56
# 14     1.69      2.25  # 18     2.26      4.00
  
```

Confinement: Tied; #3 ties with #10 bars, #4 with larger bars.  
 phi(a) = 0.8, phi(b) = 0.9, phi(c) = 0.65

Layout: Rectangular  
 Pattern: All Sides Equal (Cover to transverse reinforcement)  
 Total steel area: As = 9.48 in^2 at rho = 1.65%  
 12 #8 Cover = 1.5 in

Factored Loads and Moments with Corresponding Capacities:

```

=====

```

No.	Pu kip	Mux k-ft	fMnx k-ft	fMn/Mu	N.A. depth in	eps_t	Phi
1	1228.00	540.00	591.09	1.095	18.29	0.00055	0.650

\*\*\* End of output \*\*\*

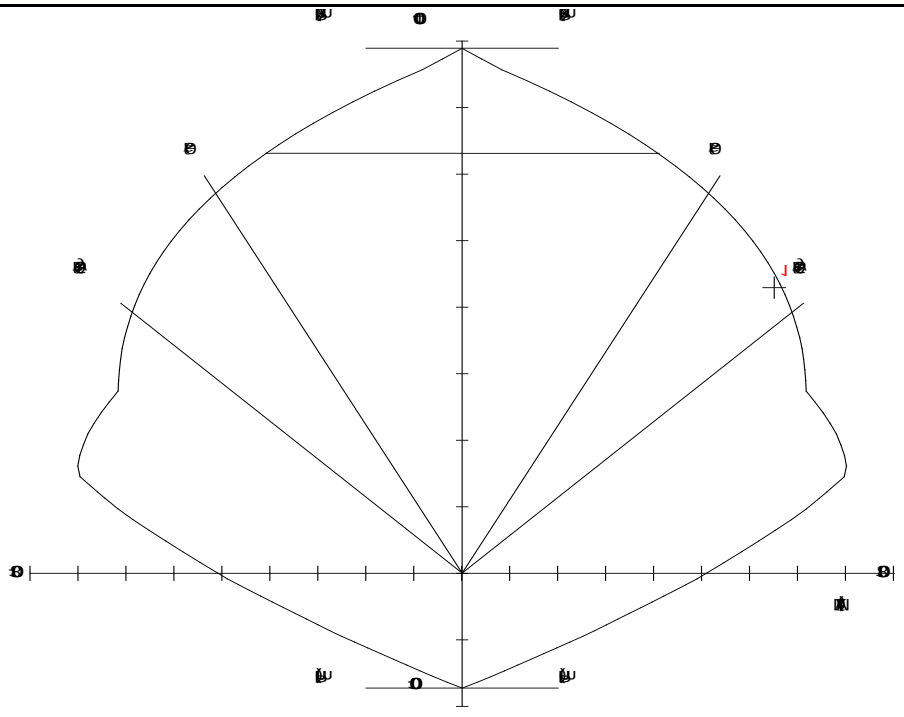

Material Properties:

```

=====
f'c = 6 ksi           fy = 60 ksi
Ec = 4415.21 ksi     Es = 29000 ksi
Ultimate strain = 0.003 in/in
Beta1 = 0.75
    
```

Section:

```

=====
Rectangular: Width = 30 in           Depth = 30 in

Gross section area, Ag = 900 in^2
Ix = 67500 in^4                     Iy = 67500 in^4
Xo = 0 in                           Yo = 0 in
    
```

Reinforcement:

```

=====
Bar Set: ASTM A615
Size Diam (in) Area (in^2)   Size Diam (in) Area (in^2)   Size Diam (in) Area (in^2)
-----
# 3      0.38      0.11   # 4      0.50      0.20   # 5      0.63      0.31
# 6      0.75      0.44   # 7      0.88      0.60   # 8      1.00      0.79
# 9      1.13      1.00   # 10     1.27      1.27   # 11     1.41      1.56
# 14     1.69      2.25   # 18     2.26      4.00
    
```

Confinement: Tied; #3 ties with #10 bars, #4 with larger bars.  
 phi(a) = 0.8, phi(b) = 0.9, phi(c) = 0.65

Layout: Rectangular  
 Pattern: All Sides Equal (Cover to transverse reinforcement)  
 Total steel area: As = 16.00 in^2 at rho = 1.78%  
 16 #9 Cover = 1.5 in

Factored Loads and Moments with Corresponding Capacities:

No.	Pu kip	Mux k-ft	fMnx k-ft	fMn/Mu	N.A. depth in	eps_t	Phi
1	2250.00	623.00	1069.66	1.717	26.20	0.00016	0.650

\*\*\* End of output \*\*\*

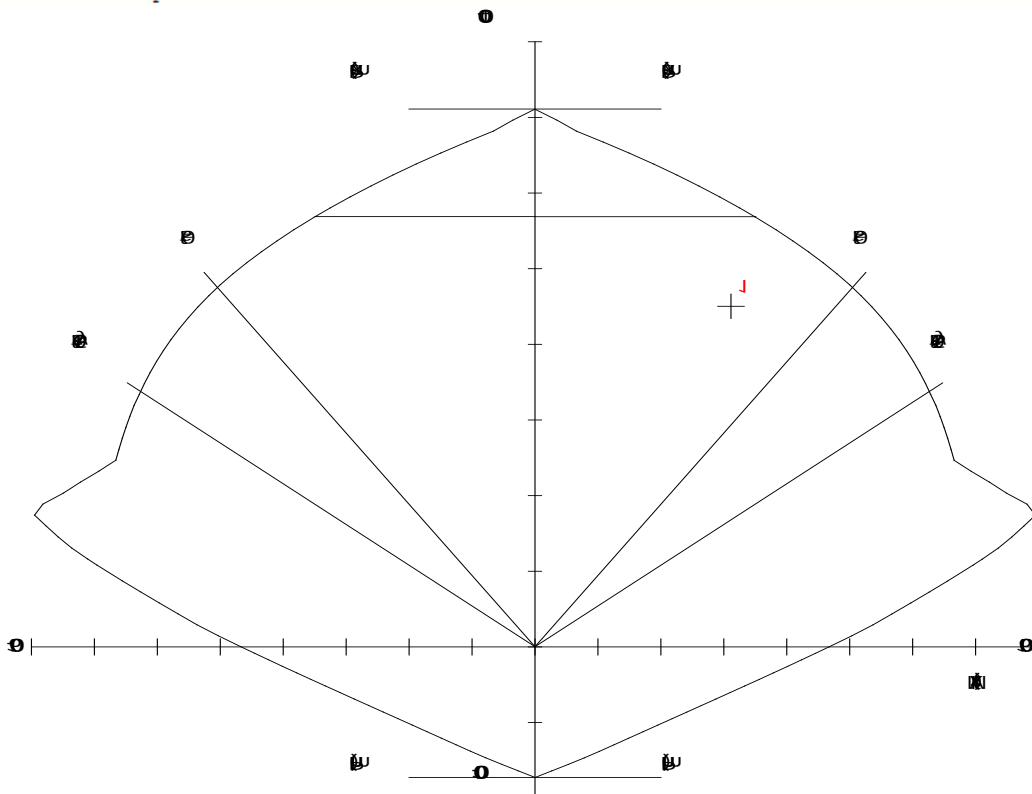

Material Properties:

```

=====
f'c = 6 ksi          fy = 60 ksi
Ec = 4419.21 ksi    Es = 29000 ksi
Ultimate strain = 0.003 in/in
Beta1 = 0.75
  
```

Section:

```

=====
Circular:   Diameter = 36 in

Gross section area, Ag = 1017.88 in^2
Ix = 82448 in^4          Iy = 82448 in^4
Xo = 0 in                Yo = 0 in
  
```

Reinforcement:

```

=====
Bar Set: ASTM A615
Size Diam (in) Area (in^2)   Size Diam (in) Area (in^2)   Size Diam (in) Area (in^2)
-----
# 3      0.38      0.11   # 4      0.50      0.20   # 5      0.63      0.31
# 6      0.75      0.44   # 7      0.88      0.60   # 8      1.00      0.79
# 9      1.13      1.00   # 10     1.27      1.27   # 11     1.41      1.56
# 14     1.69      2.25   # 18     2.26      4.00
  
```

Confinement: Tied; #3 ties with #10 bars, #4 with larger bars.  
 phi(a) = 0.8, phi(b) = 0.9, phi(c) = 0.65

Layout: Circular  
 Pattern: All Sides Equal (Cover to transverse reinforcement)  
 Total steel area: As = 16.00 in^2 at rho = 1.57%  
 16 #9 Cover = 1.5 in

Factored Loads and Moments with Corresponding Capacities:

```

=====
No.      Pu      Mux      fMnx      fMn/Mu  N.A. depth  eps_t  Phi
kip      k-ft      k-ft
-----
1        2145.00  1300.00  1332.16  1.025   26.60  0.00078  0.650
  
```

\*\*\* End of output \*\*\*

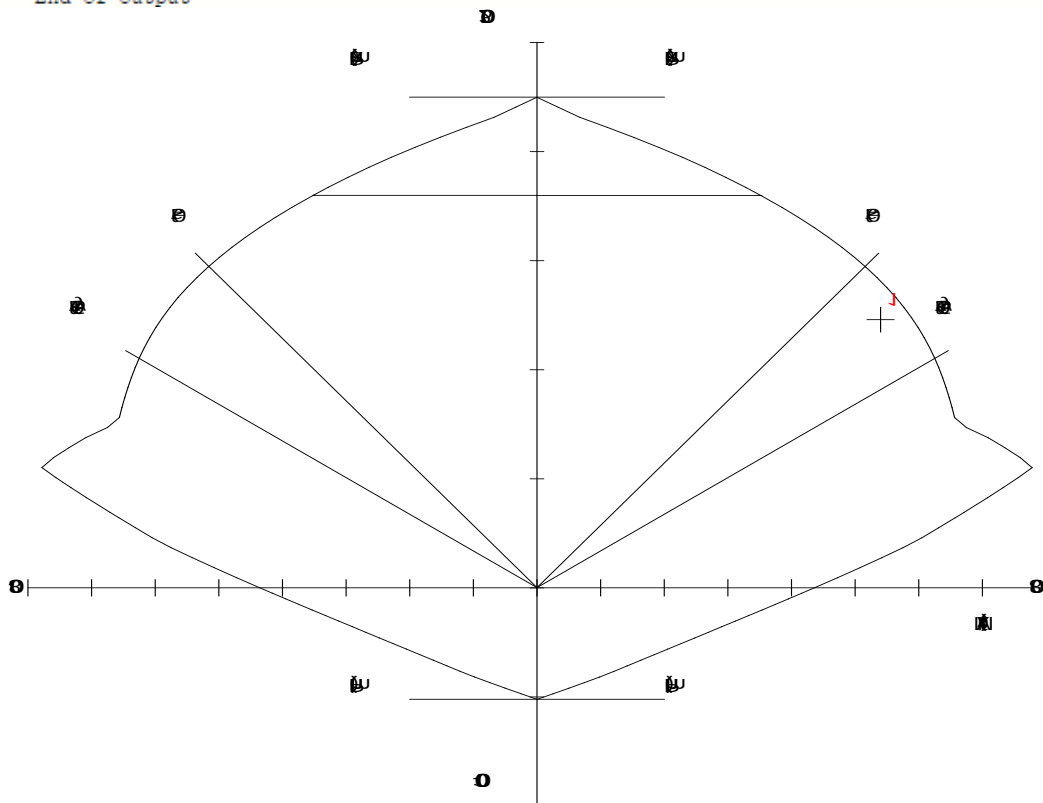

Sloped Column Design

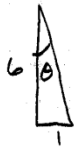
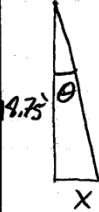
	<p><u>Sloped Column</u></p> <p>→ Max slope as specified on structural document 1:6</p>  <p><math>\tan \theta = 1/6 \Rightarrow \theta = 9.5^\circ</math></p>  <p><math>\tan(9.5) = \frac{x}{(12 \times 18.75)} \Rightarrow x = 38"</math></p>	
	<p><u>Column Reinf</u></p> <p>12.17: Classify col reinf required to be Class B lap splices</p> <p>12.16.1: Compression lap splice length, <math>l_{cs}</math></p> <p>→ not less than 12"</p> <p>→ <math>l_{cs} = .0055 f_y d_b</math></p> <ul style="list-style-type: none"> <li>• #9 <math>\Rightarrow (.0055)(60000)(1.128) = 34"</math> min</li> <li>• #8 <math>\Rightarrow (.0055)(60000)(1.0) = 30"</math> min</li> </ul> <p>12.15: Splices of deformed bars in tension</p> <p>→ Class B <math>\Rightarrow 1.3 l_d</math></p> <p>12.2.2 <math>\rightarrow l_d = \sum \frac{\psi_b \psi_c}{20 \sqrt{f_c'}} d_b</math>      <math>\psi_c = 1.0</math> &amp; <math>\psi_c = 1.0</math> &amp; <math>\lambda = 1.0</math></p> <p><math>= \frac{(60)(1.0)(1.0)}{(20)(1.0)\sqrt{6000}} (1.128) = 43.75"</math></p> <p>∴ tension splices <math>\Rightarrow 1.3(43.75) \approx 57"</math></p> <p>* Spiral ties may multiply by .75 <math>\Rightarrow 43"</math></p>	

12.5: Standard hook in tension Develop Length

→ 12.5.2: deformed bar l<sub>dh</sub> =  $\frac{(0.2) \psi_e f_y}{\lambda \sqrt{f_c'}} d_b$

$$= \frac{(0.2)(1.0)(60)}{1.0 \sqrt{6000}} (1.128) = 17.5''$$

• may be multiplied by .8 if 180°-hook enclosed w/ ties & not spaced greater than 3d<sub>b</sub>

$$3d_b = (3)(1.128) = 3.4''$$

12.16: Deformed bar compression splices

#9 =  $0.0005 f_y d_b = 34''$

#8 =  $0.0005 f_y d_b = 30''$

12.3: Deformed bar compression develop. length

12.3.2 ⇒  $l_{dc} = \begin{cases} 0.0003 f_y d_b = (0.0003)(60000)(1.128) = 20.5'' \\ \frac{0.2 f_y}{\lambda \sqrt{f_c'}} d_b = \frac{(0.2)(60000)}{1.0 \sqrt{6000}} (1.128) = 17.5'' \end{cases}$   
max

Comp: Use 34" splice w/ 21" develop length min

Tension: Use 57" splice w/ 43.75" develop length min



3

Sloped Column Corbel

$$\frac{a_v}{d} = \frac{2^{\prime\prime}}{38} = .053 < 1.0$$

11.8.2: edge depth >  $d/2$

$$\text{edge depth} > 38/2 = 19^{\prime\prime}$$

$$12 + 8 = 20 > 19 \quad \checkmark \text{ OK}$$

11.8.3: Must Support 1)  $V_u$

$$2) V_u a_v + N_{uc}(h-d) = M_u$$

$$\phi = .75$$

$$3) N_{uc}$$

$$11.8.3.2.1: V_u = 0.2 f_c' b_w d = (.2) \left( \frac{6000}{1000} \right) (208) (38) = 9485^k$$

$$= 480 + .099 f_c' b_w d = \left[ 480 + (.09) (6000) \right] \left( \frac{208}{1000} \right) \left( \frac{38}{1000} \right) = 7590^k$$

$$= 1600 b_w d = (1600) (208) (38) \neq \text{By insp}$$

$$V_u \leq 7590^k$$

11.8.3.3:  $A_s$  to resist moment

$$M_u = V_u a_v + N_{uc}(h-d)$$

$$12573^k \cdot 11 = (2110)(2^{\prime\prime}) + (N_{uc})(48^{\prime\prime} - 46^{\prime\prime})$$

$$6286.5^k = 2110 + N_{uc}$$

$$N_{uc} = 4175^k$$

11.8.3.4:  $\phi A_n F_y \geq N_{uc}$

$$(.75) A_n (60) \geq 4175^k$$

Tension  
Reinf

$$A_n \geq 52 \text{ in}^2$$

11.8.3.2: shear Friction Reinf

$$V_n = A_{vf} f_y u$$
$$7590 = A_{vf} (60) (1.4 (1.0))$$
$$A_{vf} = 90 \text{ in}^2$$

11.8.3.5:  $A_{sc} = \frac{2}{3} A_{vf} + A_n$

$$= (\frac{2}{3})(90) + (52 \text{ in}^2)$$
$$= 112 \text{ in}^2$$

But since a bm is added  $A_n = 0 \text{ in}^2$

$$\therefore A_{sc} = 60 \text{ in}^2$$

11.8.4:  $A_n \rightarrow$  Area closed to stirrups

$$A_n = \frac{1}{2} (A_{sc} - A_{vf}) = (\frac{1}{2})(60) = 30 \text{ in}^2$$

w/  $A_n$  dist: uniformly b/n  $\frac{2}{3}d$

Transfer Beam

21.7.5.1:  $l_d = \begin{cases} 8d_b & = (8)(1.128) = 9.0'' \\ 6'' & = 6'' \\ \frac{S_y d_b}{6.5 \sqrt{f_c'}} & = \frac{(60000)(1.128)}{6.5 \sqrt{6000}} = 13.44'' \end{cases}$

$$\therefore l_d = 13.5''$$

12.7.5.2: If straight bar use  $2.5l_d$

$$\therefore l_{d2} = 33.75''$$

## Appendix F: Building Envelope Study

### Glazing Calculations

	VISION GLASS		1
3)	<p>VIRACON VRE-46 IGU</p> <p><u>EXT:</u> 1/4" Clear HS (6mm)            VRE 46 Coating on #2 surface</p> <p><u>Air Space:</u> 1/2" air (12mm)</p> <p><u>INT:</u> 1/4" Clear HS (6mm)</p> <p><u>LOAD RESISTANCE</u></p> <p><u>LITE SIZE:</u> 7'-7 1/4" x 5'-0" (2317.75mm x 1524mm)            Area = 3.53 m<sup>2</sup></p> <p>1) Determine Nonfactored Load (NFL) From table A1.6            NFL = 1.48 kPa for EXT &amp; INT LITE</p> <p>2) Determine Glass Type Factor (GTF) from table 2            GTF<sub>out</sub> = GTF<sub>in</sub> = 1.8 for HS Mono</p> <p>3) Determine Load Sharing (LS) from table 5 for 3 sec short duration loading.            LS<sub>out</sub> = LS<sub>in</sub> = 2.0 for HS Mono</p> <p>4) Calc Load Resistance (LR) based on short duration load            LR = NFL x GTF x LS            = (1.48 kPa) (1.8) (2.0) = 5.328 kPa</p> <p>1 kPa = 20.9 psf ⇒ <span style="border: 1px solid black; padding: 2px;">LR = 111.3 psf</span></p>		

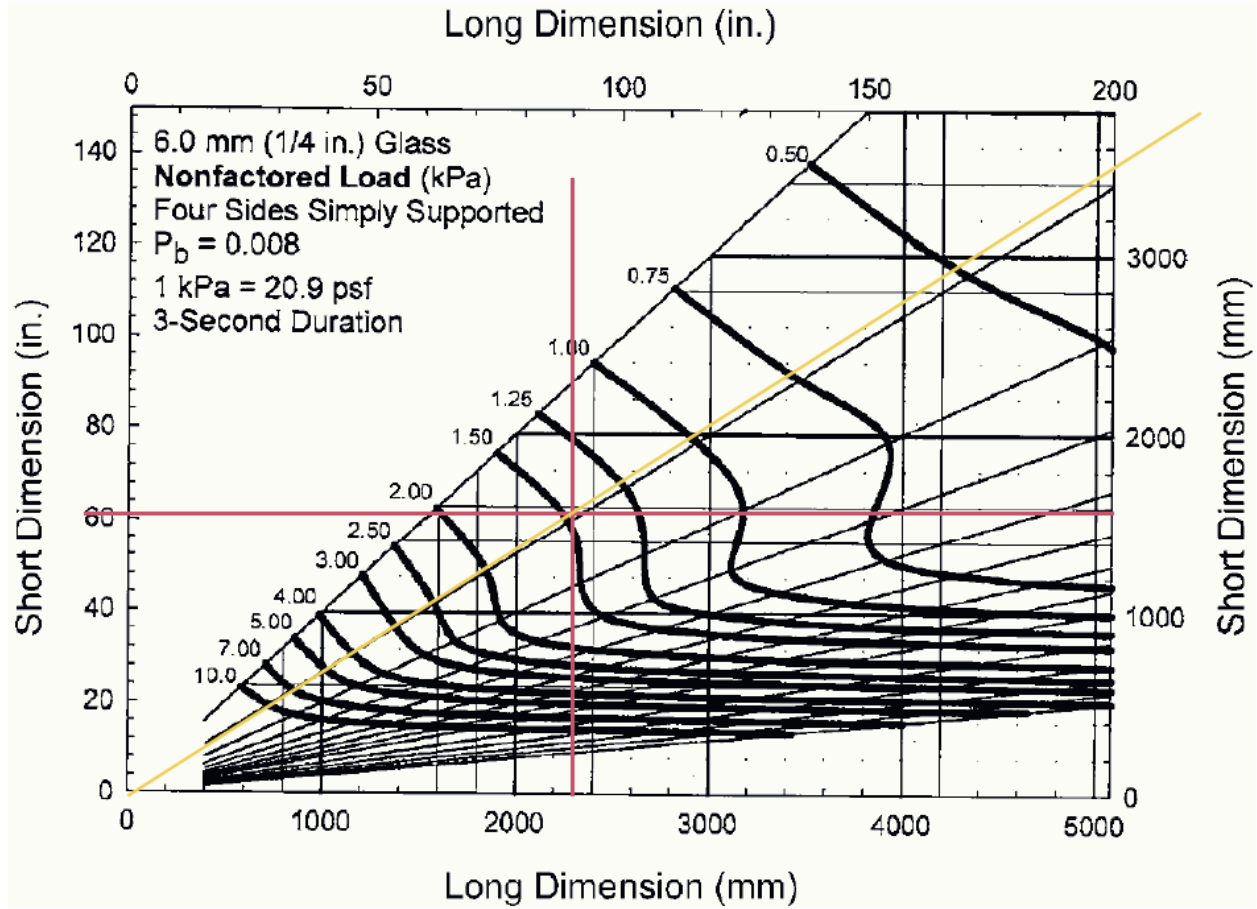

**TABLE 1 Glass Type Factors (GTF) for a Single Lite of Monolithic or Laminated Glass (LG)**

Glass Type	GTF	
	Short Duration Load (3 s)	Long Duration Load (30 days)
AN	1.0	0.43
HS	2.0	1.3
FT	4.0	3.0

**TABLE 2 Glass Type Factors (GTF) for Double Glazed Insulating Glass (IG), Short Duration Load**

Lite No. 1 Monolithic Glass or Laminated Glass Type	Lite No. 2 Monolithic Glass or Laminated Glass Type					
	AN		HS		FT	
	GTF1	GTF2	GTF1	GTF2	GTF1	GTF2
AN	0.9	0.9	1.0	1.9	1.0	3.8
HS	1.9	1.0	1.8	1.8	1.9	3.8
FT	3.8	1.0	3.8	1.9	3.6	3.6

**TABLE 3 Glass Type Factors (GTF) for Double Glazed Insulating Glass (IG), Long Duration Load (30 day)**

Lite No. 1 Monolithic Glass or Laminated Glass Type	Lite No. 2 Monolithic Glass or Laminated Glass Type					
	AN		HS		FT	
	GTF1	GTF2	GTF1	GTF2	GTF1	GTF2
AN	0.39	0.39	0.43	1.25	0.43	2.85
HS	1.25	0.43	1.25	1.25	1.25	2.85
FT	2.85	0.43	2.85	1.25	2.85	2.85

**TABLE 5 Load Share (LS) Factors for Double Glazed Insulating Glass (IG) Units**

NOTE: 1—Lite No. 1 Monolithic glass, Lite No. 2 Monolithic glass, short or long duration load, or Lite No. 1 Monolithic glass, Lite No. 2 Laminated glass, short duration load only, or Lite No. 1 Laminated Glass, Lite No. 2 Laminated Glass, short or long duration load.

Lite No. 1		Lite No. 2																						
Monolithic Glass		Monolithic Glass, Short or Long Duration Load or Laminated Glass, Short Duration Load Only																						
Nominal Thickness	2.5 ( <sup>3</sup> / <sub>32</sub> )	2.7 (lami)		3 ( <sup>1</sup> / <sub>8</sub> )		4 ( <sup>5</sup> / <sub>32</sub> )		5 ( <sup>9</sup> / <sub>32</sub> )		6 ( <sup>1</sup> / <sub>4</sub> )		8 ( <sup>7</sup> / <sub>16</sub> )		10 ( <sup>5</sup> / <sub>8</sub> )		12 ( <sup>1</sup> / <sub>2</sub> )		16 ( <sup>3</sup> / <sub>4</sub> )		19 ( <sup>3</sup> / <sub>4</sub> )				
		LS1	LS2	LS1	LS2	LS1	LS2	LS1	LS2	LS1	LS2	LS1	LS2	LS1	LS2	LS1	LS2	LS1	LS2	LS1	LS2	LS1	LS2	
2.5 ( <sup>3</sup> / <sub>32</sub> )	2.00	2.00	2.73	1.58	3.48	1.40	6.30	1.19	10.5	1.11	18.1	1.06	41.5	1.02	73.8	1.01	169.	1.01	344.	1.00	606.	1.00		
2.7 (lami)	1.58	2.73	2.00	2.00	2.43	1.70	4.12	1.32	6.50	1.18	10.9	1.10	24.5	1.04	43.2	1.02	98.2	1.01	199.	1.01	351.	1.00		
3 ( <sup>1</sup> / <sub>8</sub> )	1.40	3.48	1.70	2.43	2.00	2.00	3.18	1.46	4.83	1.26	7.91	1.14	17.4	1.06	30.4	1.03	68.8	1.01	140.	1.01	245.	1.00		
4 ( <sup>5</sup> / <sub>32</sub> )	1.19	6.39	1.32	4.12	1.46	3.18	2.00	2.00	2.76	1.57	4.18	1.31	8.53	1.13	14.5	1.07	32.2	1.03	64.7	1.02	113.	1.01		
5 ( <sup>9</sup> / <sub>32</sub> )	1.11	10.5	1.18	6.50	1.26	4.83	1.57	2.76	2.00	2.00	2.80	1.56	5.27	1.23	8.67	1.13	18.7	1.06	37.1	1.03	64.7	1.02		
6 ( <sup>1</sup> / <sub>4</sub> )	1.06	18.1	1.10	10.9	1.14	7.91	1.31	4.18	1.56	2.80	2.00	2.00	3.37	1.42	5.26	1.23	10.8	1.10	21.1	1.05	38.4	1.03		
8 ( <sup>5</sup> / <sub>16</sub> )	1.02	41.5	1.04	24.5	1.06	17.4	1.13	8.53	1.23	5.27	1.42	3.37	2.00	2.00	2.80	1.56	5.14	1.24	9.46	1.12	15.9	1.07		
10 ( <sup>5</sup> / <sub>8</sub> )	1.01	73.8	1.02	43.2	1.03	30.4	1.07	14.5	1.13	8.67	1.23	5.26	1.56	2.80	2.00	2.00	3.31	1.43	5.71	1.21	9.31	1.12		
12 ( <sup>1</sup> / <sub>2</sub> )	1.01	169.	1.01	98.2	1.01	68.8	1.03	32.2	1.06	18.7	1.10	10.8	1.24	5.14	1.43	3.31	2.00	2.00	3.04	1.49	4.60	1.28		
16 ( <sup>3</sup> / <sub>4</sub> )	1.00	344.	1.01	199.	1.01	140.	1.02	64.7	1.03	37.1	1.05	21.1	1.12	9.46	1.21	5.71	1.49	3.04	2.00	2.00	2.76	1.57		
19 ( <sup>3</sup> / <sub>4</sub> )	1.00	606.	1.00	351.	1.00	245.	1.01	113.	1.02	64.7	1.03	36.4	1.07	15.9	1.12	9.31	1.28	4.80	1.57	2.76	2.00	2.00		

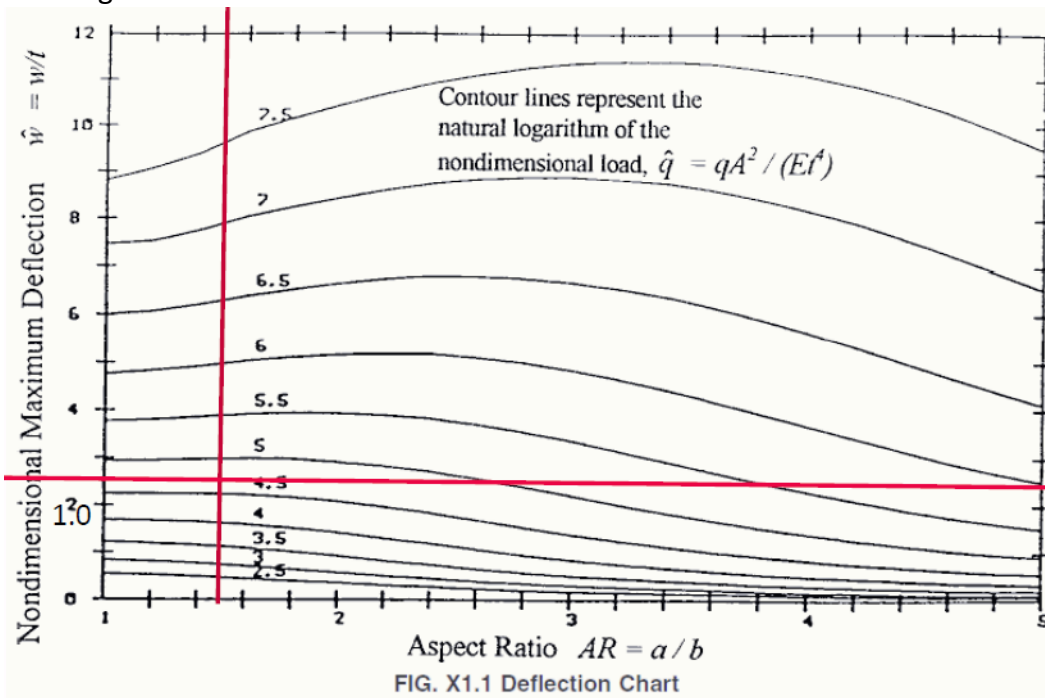

Long Dimension (mm)

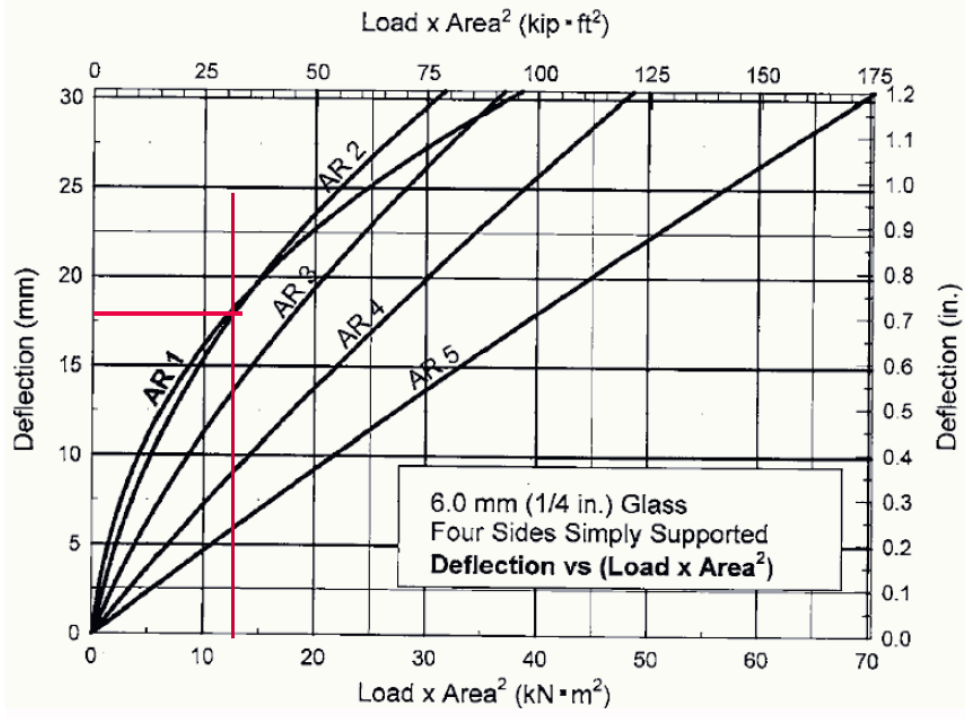

2

Deflection Determination @ Center

Max load of 12.44 psf @ level 10 for glazing

$$12.44 \text{ psf} = 0.595 \text{ kPa}$$

$$\text{Load} \times \text{Area}^2 = (.595 \text{ kPa})(3.53 \text{ m}^2)^2 = 7.426 \text{ kNm}^2$$

$$\text{Aspect Ratio} = \frac{2317.75 \text{ mm}}{1524 \text{ mm}} = 1.52$$

Using Figure A1.66: Deflection = 18 mm

Mullion Design

$$12.44 \text{ psf Load} = .596 \text{ kN/m}^2$$

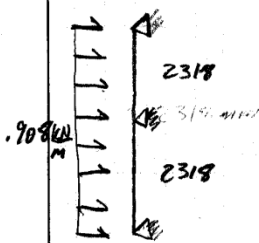

LD bay width: 1524 mm

$$\text{Load: } .596 \frac{\text{kN}}{\text{m}^2} \times 1.524 \text{ m} = .908 \frac{\text{kN}}{\text{m}}$$

Assume:

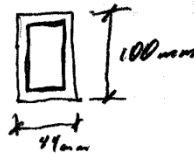

Table 3.2:

$$+M_{\text{max}} = K_m q L^2 \Rightarrow (.0703)(.908 \frac{\text{kN}}{\text{m}})(2.32 \text{ m})^2 = .344 \text{ kNm}$$

$$-M_{\text{max}} = K_b q L^2 \Rightarrow (-.125)(.908 \frac{\text{kN}}{\text{m}})(2.32 \text{ m})^2 = -.611 \text{ kNm}$$

$$Q_{\text{max}} = K_a q L \Rightarrow (.625)(.908 \frac{\text{kN}}{\text{m}})(2.32 \text{ m}) = 1.32 \text{ kN}$$

$$\Delta_{\text{max}} = K_d q L^4 \frac{1}{100EI} \Rightarrow \frac{(.521)(.908 \frac{\text{kN}}{\text{m}})(2.32 \text{ m})^4}{(100)EI} = \frac{0.137 \text{ kNm}^2}{EI}$$

Bearing on Middle Support:

$$(.625 + .625)(.908 \frac{\text{kN}}{\text{m}})(2318) = \boxed{2631 \text{ N}}$$

$$= \boxed{0.59 \text{ kips}}$$

### **Anchor Determination**

- Test Results performed by Wiss, Janney, Elstner Associates, Inc. Report WJE No. 2002.2579.

	<b>Small Clips (HCWL1/HCWR 1)</b>	<b>Medium Clips (HCWL2/HCWR 2)</b>	<b>Large Clips (HCWL3/HCWR 3)</b>
Dead Load Configuration Average Ultimate Load	6400 lbs	6550 lbs	6650 lbs
Wind Load Configuration Average Ultimate Load	9900 lbs	8750 lbs	8800 lbs

- Loads shown are for pair of clips, with maximum eccentricity.
- **LIMITATIONS**
  - Calculations required for anchor application, to suit specific uses.
  - Mullion bolt and nut are not part of the assembly.
  - Anchor channel and fasteners must be engineered, considering eccentricity of clips.
- **SAFETY PRECAUTIONS**
  - Nylatron shims may be used between wind load clip and mullion to reduce friction.
  - Insulating shims may be used between backside of clip and structure to avoid galvanic action.
- **AVAILABILITY**
  - Product is available across North America.
- **COST**
  - Varies with substrate condition and configuration, and relative size of building.
  - Consult manufacturer national or regional offices for specific product costs or relative costs.

### **PRODUCT PROPERTIES**

- **MATERIALS AND PROPERTIES**
  - Clips:
    - ASTM B221/B221M, Alloy 6005, Temper T5, extruded aluminum,
    - With impressed serrations gripping for serrated anchor washers,
    - Pilot hole for temporary fixing is standard.
  - Dead load clips:
    - Carry dead load, and wind/suction loads.
    - Marked "L" (left) or "R" (right) and "UP".
    - Two serrated washers required per dead load clip.
  - Wind load clips:
    - Resist wind/suction loads only.
    - One serrated washer required per wind load clip.
  - Shims: Nylatron, low-friction shims for wind load clips.



# Appendix G: Sequencing Study

## Existing Building Schedule

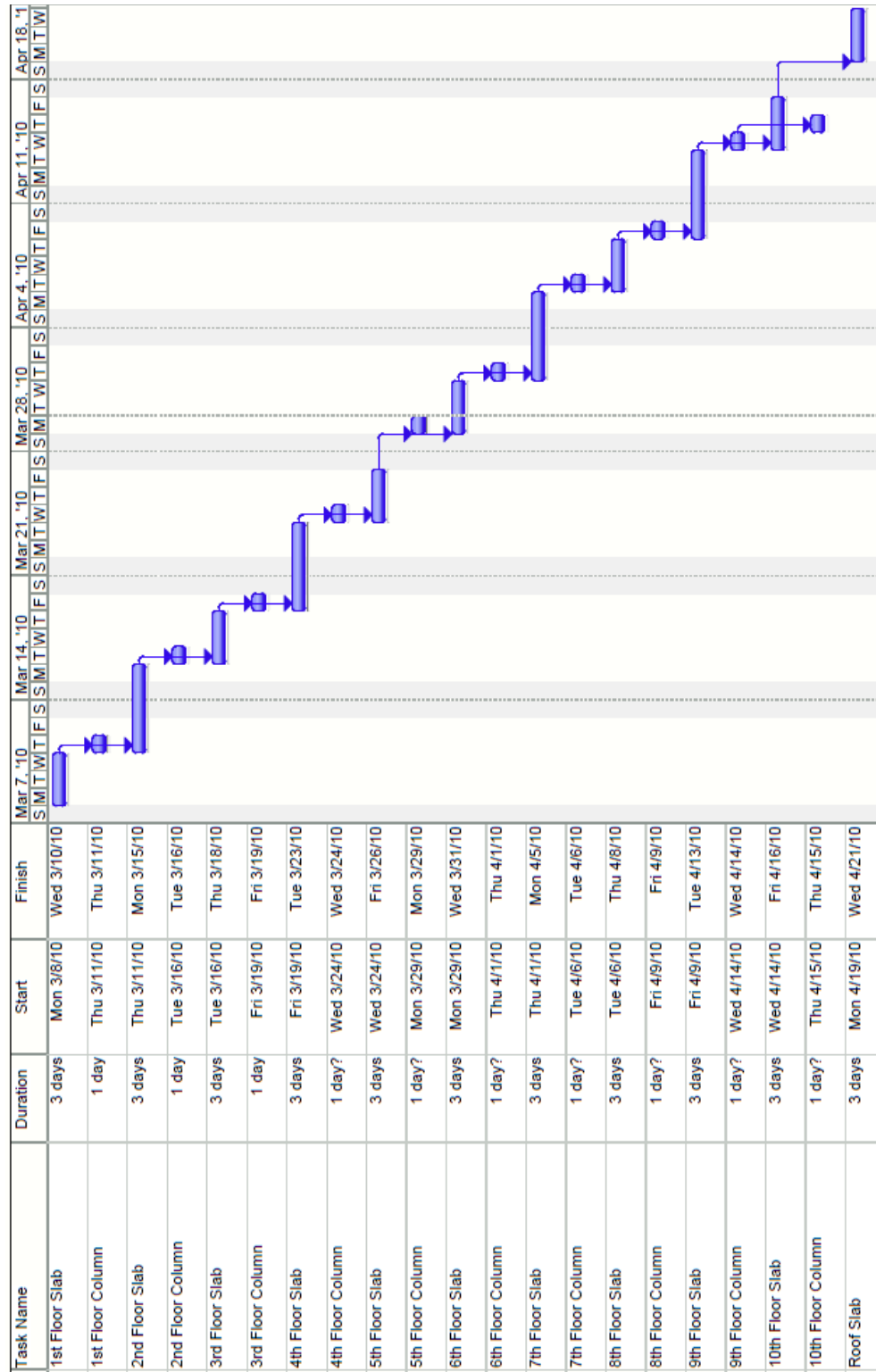

**Thesis Redesign Schedule**

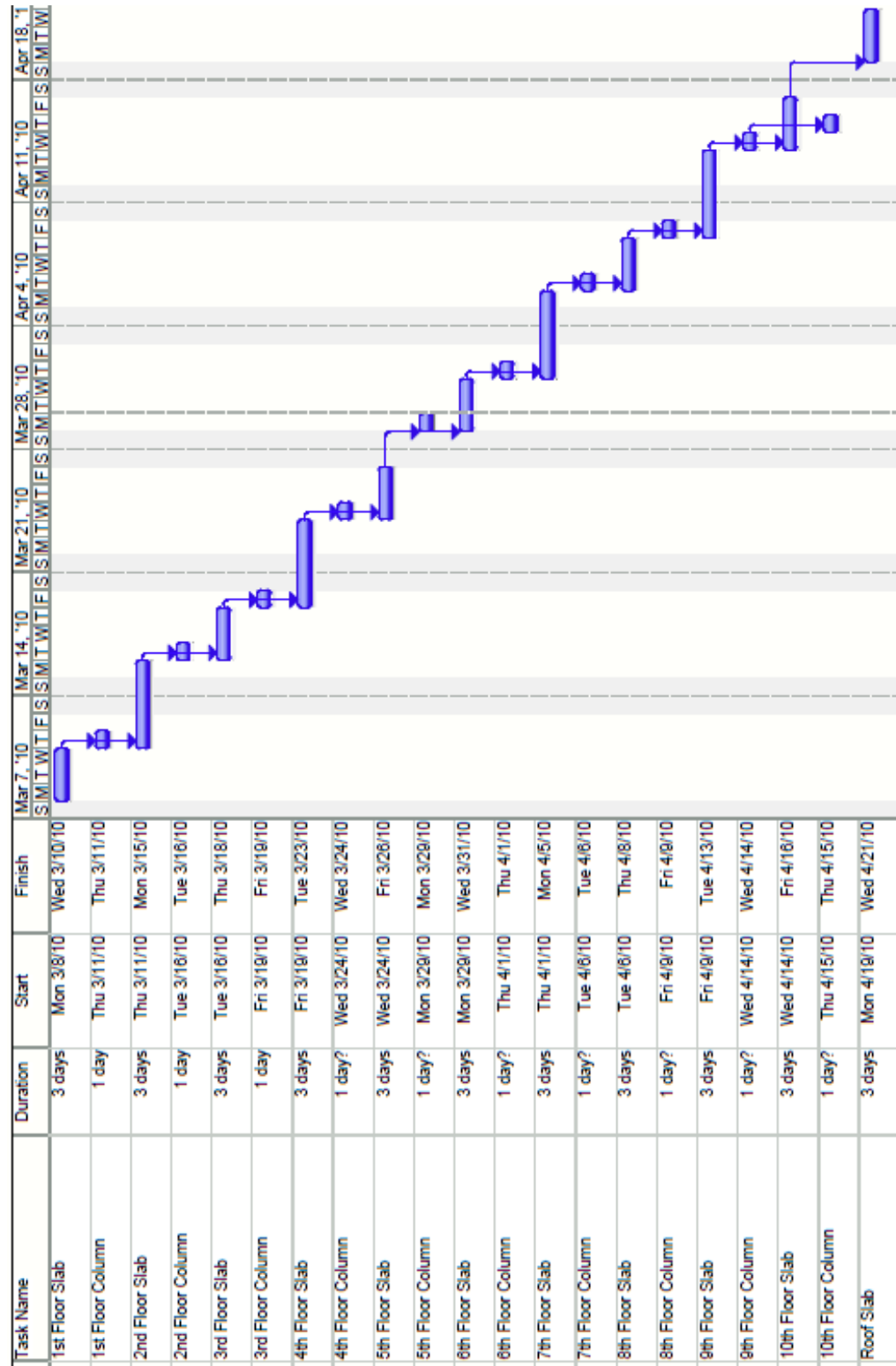

# Appendix H: Cost Study

## Existing Building Cost

Description	Quantity	Crew	Daily Output	Labor Hours	Unit	Material	Labor	Employee Int	Emp. Total	Ext. Mat.	Ext. Labor	Ext. Equip.	Ext. Total	Max. OMP	Labor OMP	Equip. OMP	Total OMP	Ext. Mat. OMP	Ext. Labor OMP	Ext. Equip. OMP	Ext. Total OMP	
Structural concrete, ready mix, normal weight, 4000 psi, includes all aggregate, sand, Portland cement and water delivered, excludes all additives and treatments	1185				C.Y.	\$ 119.13			\$ 119.13	\$ 100,504.05			\$ 100,504.05	\$ 100.52	\$ 442,816.20		\$ 543,316.25	\$ 100.52			\$ 142,816.20	
Structural concrete, ready mix, normal weight, 5000 psi, includes local aggregate, sand, Portland cement and water delivered, excludes all additives and treatments	8612				C.Y.	\$ 115.33			\$ 993,221.96	\$ 993,221.96			\$ 993,221.96	\$ 108.76	\$ 1,091,657.12		\$ 2,084,879.08	\$ 108.76			\$ 1,091,657.12	
Structural concrete, ready mix, normal weight, 6000 PSI, includes local aggregate, sand, Portland cement and water delivered, excludes all additives and treatments	1150				C.Y.	\$ 131.95			\$ 151,742.50	\$ 151,742.50			\$ 151,742.50	\$ 144.42	\$ 166,030.00		\$ 317,772.50	\$ 144.42			\$ 166,030.00	
Structural concrete, ready mix, normal weight, 8000 PSI, includes local aggregate, sand, Portland cement and water delivered, excludes all additives and treatments	790				C.Y.	\$ 214.03			\$ 169,683.70	\$ 169,683.70			\$ 169,683.70	\$ 235.85	\$ 186,321.50		\$ 356,005.20	\$ 235.85			\$ 186,321.50	
Structural concrete, ready mix, normal weight, 3000 psi, includes local aggregate, sand, Portland cement and water delivered, excludes all additives and treatments	862				C.Y.	\$ 104.94			\$ 90,459.28	\$ 90,459.28			\$ 90,459.28	\$ 115.33	\$ 99,144.46		\$ 189,603.74	\$ 115.33			\$ 99,144.46	
Small, elevated, pumped, includes ultrating, excludes material	550	C20	60	1.07	C.Y.		\$ 28.91	\$ 13.43	\$ 42.34		\$ 15,900.50	\$ 7,386.50	\$ 23,287.00		\$ 44.57	\$ 14.75	\$ 59.32		\$ 24,513.50	\$ 8,112.50	\$ 32,626.00	
Structural concrete, ready mix, normal weight, 4000 psi, includes all aggregate, sand, Portland cement and water delivered, excludes all additives and treatments	2050	C20	92	0.7	C.Y.		\$ 18.87	\$ 8.78	\$ 27.65		\$ 38,872.20	\$ 18,095.80	\$ 56,968.00		\$ 28.91	\$ 9.65	\$ 38.56		\$ 59,654.40	\$ 19,879.00	\$ 79,433.60	
Structural concrete, placing, elevated slab, 3000 psi, includes local aggregate, sand, Portland cement and water delivered, excludes all additives and treatments	8612	C20	160	0.4	C.Y.		\$ 10.89	\$ 6.04	\$ 15.92		\$ 93,698.55	\$ 43,404.48	\$ 137,103.04		\$ 16.86	\$ 5.56	\$ 22.42		\$ 145,198.32	\$ 47,892.72	\$ 193,091.04	
Structural concrete, placing, continuous footing, shallow, pumped, includes ultrating, excludes material	862	C20	150	0.45	C.Y.		\$ 11.60	\$ 5.36	\$ 16.96		\$ 9,999.20	\$ 4,830.32	\$ 14,829.52		\$ 17.67	\$ 5.92	\$ 23.59		\$ 15,231.54	\$ 5,103.04	\$ 20,334.58	
Structural concrete, placing, slab on grade, direct chute, up to 8" thick, includes ultrating, excludes material	100	C6	110	0.44	C.Y.		\$ 11.56	\$ 0.48	\$ 12.04		\$ 1,546.00	\$ 48.00	\$ 1,594.00		\$ 17.67	\$ 0.53	\$ 18.20		\$ 1,767.00	\$ 53.00	\$ 1,820.00	
Structural concrete, placing, elevated slab, 3000 psi, includes local aggregate, sand, Portland cement and water delivered, excludes all additives and treatments	300020	C10	2000	0.015	F		\$ 0.35		\$ 106,267.00		\$ 106,267.00		\$ 106,267.00		\$ 0.51		\$ 106,777.00		\$ 154,846.20		\$ 154,846.20	
C1/P concrete forms, beams and girders, 2x8, includes ultrating, bracing, stripping and cleaning	69070	C2	377	0.13	SFCA	\$ 1.31	\$ 3.67		\$ 4.98	\$ 90,481.70	\$ 253,488.50		\$ 343,970.20		\$ 1.44	\$ 5.71	\$ 7.15	\$ 99,460.80	\$ 394,389.70		\$ 493,850.50	
C1/P concrete forms, columns, square, 2x8, includes ultrating, bracing, stripping and cleaning	102250	C1	250	0.13	SFCA	\$ 0.55	\$ 3.59		\$ 4.14	\$ 56,237.50	\$ 367,077.50		\$ 423,315.00		\$ 0.61	\$ 5.56	\$ 6.17	\$ 62,372.50	\$ 485,720.00		\$ 630,862.50	
C1/P concrete forms, elevated slab, 2x8, includes ultrating, bracing, stripping and cleaning	300020	C2	644	0.09	F	\$ 1.45	\$ 2.54		\$ 3.99	\$ 440,249.00	\$ 771,194.80		\$ 1,211,443.80		\$ 1.60	\$ 3.93	\$ 5.53	\$ 485,792.00	\$ 1,193,236.80		\$ 1,679,018.60	
C1/P concrete forms, wall, job built, 2x8, includes ultrating, bracing, stripping and cleaning	820	C1	600	0.05	F	\$ 0.35	\$ 1.50		\$ 1.85	\$ 287.00	\$ 1,220.00		\$ 1,517.00		\$ 0.29	\$ 2.32	\$ 2.71	\$ 319.80	\$ 1,902.40		\$ 2,222.20	
C1/P concrete forms, wall, 2x8, includes ultrating, bracing, stripping and cleaning	24480	C2	395	0.12	SFCA	\$ 0.73	\$ 3.50		\$ 4.23	\$ 17,870.40	\$ 85,690.00		\$ 103,560.40		\$ 0.80	\$ 5.45	\$ 6.25	\$ 19,684.00	\$ 133,416.00		\$ 153,000.00	
C1/P concrete forms, wall, 2x8, includes ultrating, bracing, stripping and cleaning	4900	C2	225	0.21	SFCA	\$ 1.36	\$ 6.15		\$ 7.51	\$ 6,664.00	\$ 30,135.00		\$ 36,799.00		\$ 1.50	\$ 9.52	\$ 11.02	\$ 7,360.00	\$ 46,648.00		\$ 53,998.00	
200 mesh, 300 Mic, post-tensioned in field	139272	C4	1700	0.02	lb	\$ 0.63	\$ 0.67	\$ 0.02	\$ 1.32	\$ 82,260.36	\$ 87,483.24	\$ 2,811.44	\$ 172,555.04		\$ 0.69	\$ 1.09	\$ 0.02	\$ 1.80	\$ 90,094.68	\$ 142,923.48	\$ 2,811.44	\$ 235,029.60
W14 x W14 (10 x 10) 121 lb per C.S.F. A185	73.5	ROOM	35	0.46	C.S.F.	\$ 18.37	\$ 16.13		\$ 34.50	\$ 1,350.20	\$ 1,185.56		\$ 2,535.75		\$ 20.21	\$ 26.36	\$ 46.57	\$ 1,485.44	\$ 1,937.46		\$ 3,422.90	
Epoxy coating, for reinforcing steel, includes labor and delivered price for coating with epoxy	398				Ton	\$ 880.57			\$ 880.57	\$ 350,468.86			\$ 350,468.86		\$ 667.10		\$ 667.10	\$ 384,905.80			\$ 384,905.80	
<b>Total</b>									\$200877.51	\$1863266.46	\$19151.54		\$400801.50		\$2837657.20		\$2837657.20	\$2837657.20	\$30541.70		\$5064763.80	



DIVISION	VERMONT			ALEXANDRIA			ARLINGTON			BRISTOL			CHARLOTTESVILLE			CULPEPER		
	MAT.	INST.	TOTAL	MAT.	INST.	TOTAL	MAT.	INST.	TOTAL	MAT.	INST.	TOTAL	MAT.	INST.	TOTAL	MAT.	INST.	TOTAL
<b>015433</b>																		
<b>0241, 31 - 34</b>																		
<b>CONTRACTOR EQUIPMENT</b>																		
<b>0241, 31 - 34</b>																		
<b>SITE &amp; INFRASTRUCTURE, DEMOLITION</b>																		
0310	76.9	96.1	90.1	116.5	89.1	97.8	128.2	86.7	99.8	111.8	86.1	94.2	116.9	87.0	96.5	114.8	87.1	95.9
Concrete Forming & Accessories	91.6	46.2	52.4	94.1	76.1	78.6	93.4	74.1	76.7	89.1	48.4	53.9	87.5	55.2	59.6	85.0	73.1	74.7
0320	80.3	41.4	64.4	90.2	82.2	86.9	101.8	78.7	92.4	101.9	64.9	86.8	101.2	71.0	88.9	101.8	72.4	89.8
Concrete Reinforcing	92.8	59.4	80.0	106.8	82.9	97.7	103.9	80.3	94.9	103.5	53.5	84.4	107.6	62.2	90.3	106.4	72.5	93.4
0330																		
Cast-in-Place Concrete	101.9	50.9	78.7	108.2	80.8	95.7	113.7	77.9	97.4	109.8	55.2	85.0	110.4	62.3	88.6	107.2	73.7	92.0
<b>03</b>																		
<b>CONCRETE</b>																		
04	116.6	41.4	71.6	91.6	72.3	80.1	104.3	69.2	83.3	92.6	45.5	64.4	118.0	52.6	78.8	107.1	67.8	83.6
MASONRY	88.8	62.7	81.2	97.2	96.7	97.0	95.9	86.6	93.2	94.8	86.7	92.5	95.1	90.9	93.9	95.2	86.1	92.5
05																		
METALS	96.4	47.6	69.6	97.7	75.7	85.6	94.4	75.7	84.2	86.8	46.8	64.8	85.0	53.3	67.6	83.8	75.7	79.4
WOOD, PLASTICS & COMPOSITES	94.1	38.2	72.4	101.5	80.6	93.4	103.2	72.5	91.3	102.8	52.7	83.3	102.5	58.7	85.4	102.6	67.3	88.9
06																		
THERMAL & MOISTURE PROTECTION	101.6	43.6	87.2	98.3	78.3	93.3	96.2	72.3	90.3	99.6	50.8	87.5	97.6	57.4	87.6	97.9	68.3	90.6
07																		
OPENINGS	100.4	44.9	64.4	112.3	74.7	87.9	109.0	74.7	86.7	105.1	44.7	65.8	104.3	50.6	69.5	104.9	74.7	85.3
08																		
Plaster & Gypsum Board	88.9	44.9	61.7	97.6	74.7	83.4	93.4	74.7	81.8	92.6	44.7	63.0	92.6	50.6	66.7	93.4	74.7	81.8
0920																		
Ceilings & Acoustic Treatment	94.6	34.2	78.3	111.5	88.9	105.4	109.5	61.7	96.6	105.1	41.9	88.0	103.4	49.5	88.8	103.4	61.7	92.1
0950, 0980																		
Flooring	91.7	19.0	48.1	127.6	83.3	101.0	127.6	83.3	101.0	114.4	47.8	74.4	114.4	67.6	86.3	127.6	60.1	87.1
0960																		
Wall Finishes & Painting/Coating	94.3	40.9	66.1	105.9	78.9	91.6	105.1	73.4	88.4	101.5	46.5	72.4	100.9	54.7	76.5	101.6	70.7	85.3
0970, 0990																		
FINISHES	100.0	44.5	89.0	100.0	89.2	97.9	100.0	80.8	96.2	100.0	68.0	93.7	100.0	78.6	95.8	100.0	68.7	93.8
0990																		
DVS. 10 - 14, 25, 28, 41, 43, 44	94.4	62.7	81.8	100.2	88.5	95.5	100.2	82.4	93.1	94.4	58.1	79.9	94.4	63.8	82.2	94.4	70.5	84.9
COVERS	96.9	62.8	80.3	97.6	98.2	97.9	95.1	93.4	94.3	97.2	41.3	70.0	97.1	69.8	83.8	99.7	60.8	80.8
21, 22, 23																		
FIRE SUPPRESSION, PLUMBING & HVAC	96.3	56.6	79.7	100.7	86.0	94.5	101.5	80.8	92.8	98.7	57.4	81.4	100.0	66.6	85.9	99.3	72.0	87.9
26, 27, 3370																		
ELECTRICAL, COMMUNICATIONS & UTIL.																		
ME2004																		
WEIGHTED AVERAGE																		