

# Proposal

The Residences

Anne Arundel County, Maryland

12/10/2010

Faculty Advisor - Dr. Richard A. Behr

Ryan English - Structural Option



## Table of Contents

|   |    |
|---|----|
| Executive Summary.....  | 3  |
| Introduction.....   | 4  |
| Structural System.....  | 6  |
| Foundation System.....  | 6  |
| Framing System.....   | 7  |
| Lateral System.....   | 9  |
| Roof System.....  | 10 |
| Proposal.....   | 11 |
| Proposed Structural Depth.....  | 11 |
| Breadth Options.....  | 12 |
| Breadth Study One: In-Depth Cost and Schedule Impacts of Depth.....   | 12 |
| Breadth Study Two: Sustainability.....                                | 12 |
| Breadth Study Two Alternate: Lighting Study of Typical Apartment..... | 12 |
| Tasks and Tools.....  | 13 |
| Schedule.....   | 14 |
| Conclusion.....   | 15 |

## **Executive Summary**

The Residence is designed as a light gage metal stud bearing and shear walls which support the Hambro floor system. This thesis proposal is to pursue the development of concrete and seismic resistive systems and implement that design to The Residences. The Residence is to be redesigned with a concrete superstructure.

The floor system is to be redesigned using concrete system. A One-Way and Two-Way concrete floor system is to be investigated and design for the building using ACI310-08. The gravity loads is determined using ASCE 07-05. The lateral load is to be determined using the equivalent lateral force method and modal response spectrum analysis as prescribe in ASCE7-05 for the current location and a high seismic region. Reached is to be conducted on the use of shear walls, dampers, and base isolation systems. The lateral loads of the building are to be resisted by the use of the best system that is found from the research of the seismic resistive systems.

The change to a concrete system leads to other changes throughout the project. An in depth cost analysis and schedule impact study is to be performed to determine the changes that are due to the changes in the structural system. The scheduling changes that would involve the additional construction time for the formwork and placement of the concrete.

To achieve a sustainable building, a green roof is to be design instead of the current roofing system. The design of the green roof is to consist of a study of the layers that make up the system and the flashing and membrane involved. Also, the green roof is to be designed with the intention of retaining water, the drainage and flow of water to a central gray water collection tank is to be considered and designed. The loads from the green roof will be applied to the design of the gravity and lateral system.

## **Introduction**

Located in Anne Arundel County, Maryland the Residence is a new construction apartment and retail building which is part of the Arundel Preserve Town Center Phase I Project (Figure 1). The Residence is a five to six story, 300,000 s.f., residential apartment building with 6,000 s.f. retail space surrounding a 5 story precast parking garage. This apartment building houses 242 upscale residential units consisting of studio, one and two bedroom layouts, and two level units. Along with the residential units, the building also includes a terrace level that contains a clubhouse, health center, and an outside pool. Construction of The Residence began in the fall of 2009 and should be completed in the beginning of 2011. It is owned and managed by the Somerset Construction Company and was designed by KTGy, Vienna, VA.

The structure of The Residence is comprised of the Hambro floor system, which uses a steel bar joist that supports a concrete slab (Figure 2). The floor systems are supported by a 6" light gage metal studs bearing and shear walls located throughout the building. A more in-depth structural analysis and details will follow in this report.



Figure 1: Site plan, Light Brown area represents the building; Gray area represents the parking garage. (Construction documents by Cates Engineering).

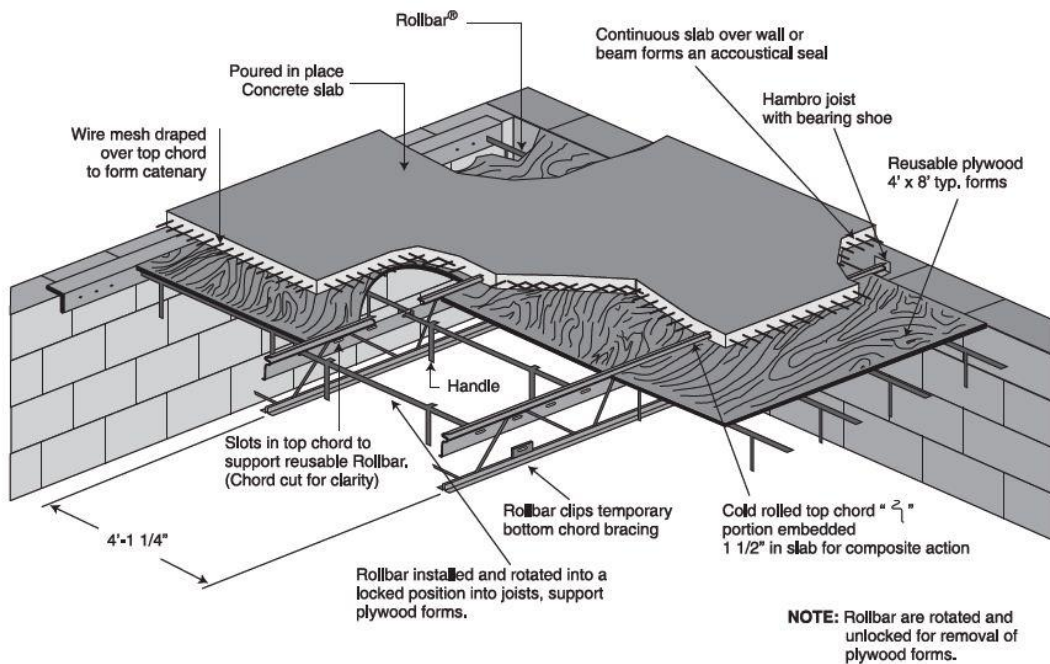
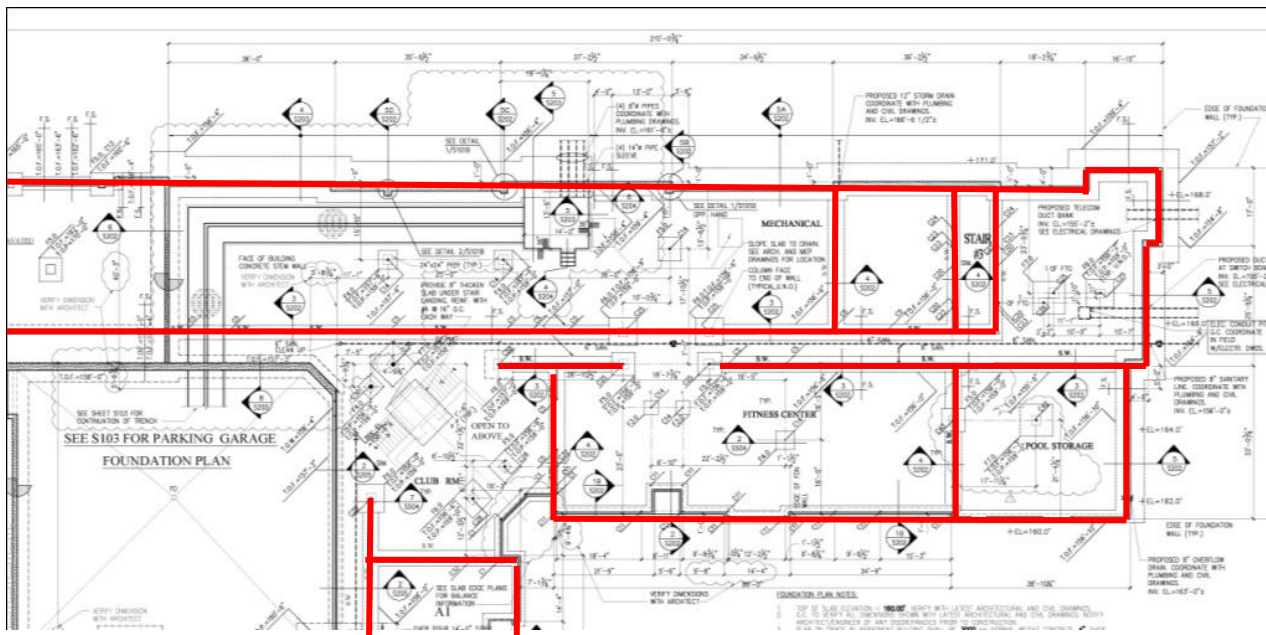

Figure 2: Hambro floor joist system. (Hambro Joist Company).

### Foundation System

According to the geotechnical report, the building rests on silt-clay facies<sup>1</sup> which is identified as clay, silt, and subordinate fine to medium grained muddy sand. The groundwater table is a minimum of 24 feet below existing grade, which is well below the foundation of the building. From the report, it is determined that the structures can be supported on shallow spread footings with an allowable bearing pressure of 5,000 pounds per square foot.

The building foundation system uses a 3'-0" wide strip footing with 3'-0"x3'-0" to 15'-0"x15'-0" column footing pads located mainly around the retail space and clubhouse area (Figure 3). The concrete slab on grade is 4" thick reinforced with 6 x 6 W1.4 xW1.4 welded wire fabric. All foundation concrete is to be 3,000 psi at 28 day strength.



**Figure 3: Foundation plan, part of the east wing. (Construction documents by Cates Engineering).**

<sup>1</sup> In geology, facies are bodies of rock with specified characteristics.

The floor system for the Residence is the Hambro floor joist system (Figure 2). The Hambro floor system uses a specially designed steel bar joist with a “S” shape top compression chord that serves three functions, a compression member in the non-composite joist during the construction stage, a chair for the welded wire fabric, and a continuous shear connection for the composite (cured concrete) stage. Detail information of the “s” shape top chord can be seen in Figure 4. The floor slab is a 3” thick 3,000 psi concrete with 6 x 6 W2.9 x W2.9 welded wire fabric. This particular floor thickness is chosen to give the system a 2 hour fire rated system. The slab is then supported by a 20” deep Hambro bar joist.

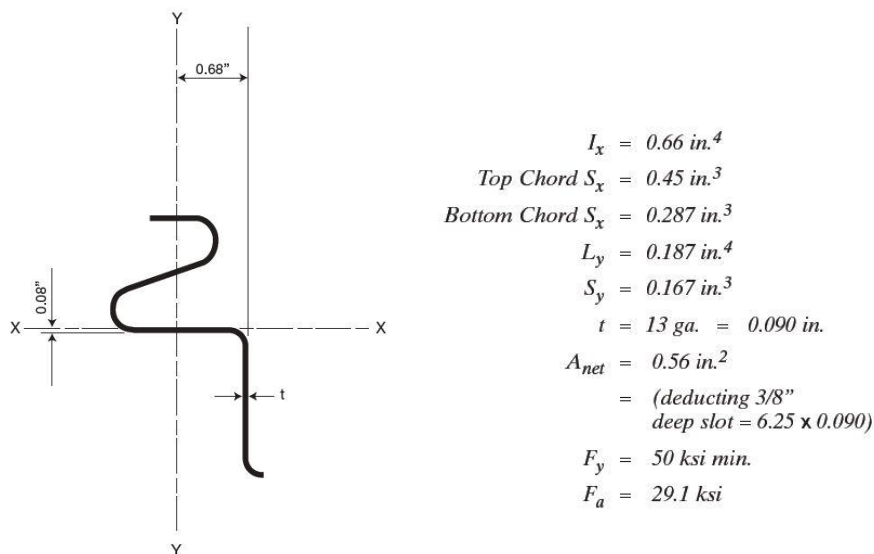

**Figure 4: Top chord of the Hambro joist "s" chord with section properties.**

### Framing System

The design framing system in the Residence is light gage steel load bearing walls that are used to support the Hambro floor system and gravity loads in the building. The particular system uses the SigmaStud® load bearing light gage steel stud, a product of The Steel Network Company. The stud design is engineered to have a significant increase in load capacity when compared to the conventional “C” shaped studs. The Residence uses

a 6" wide 18 gage stud with a flange length of 2.5", as detailed in Figure 5. The exterior wall and interior corridor walls of the Residence are the primary bearing walls in the building. Figure 6 shows the location of the bearing walls in the building.

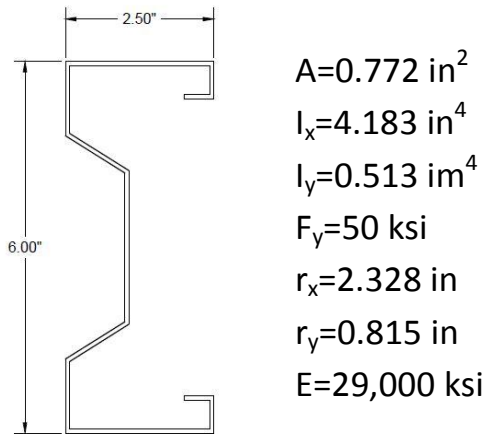

Figure 5: Section of light gage steel stud, with section properties.

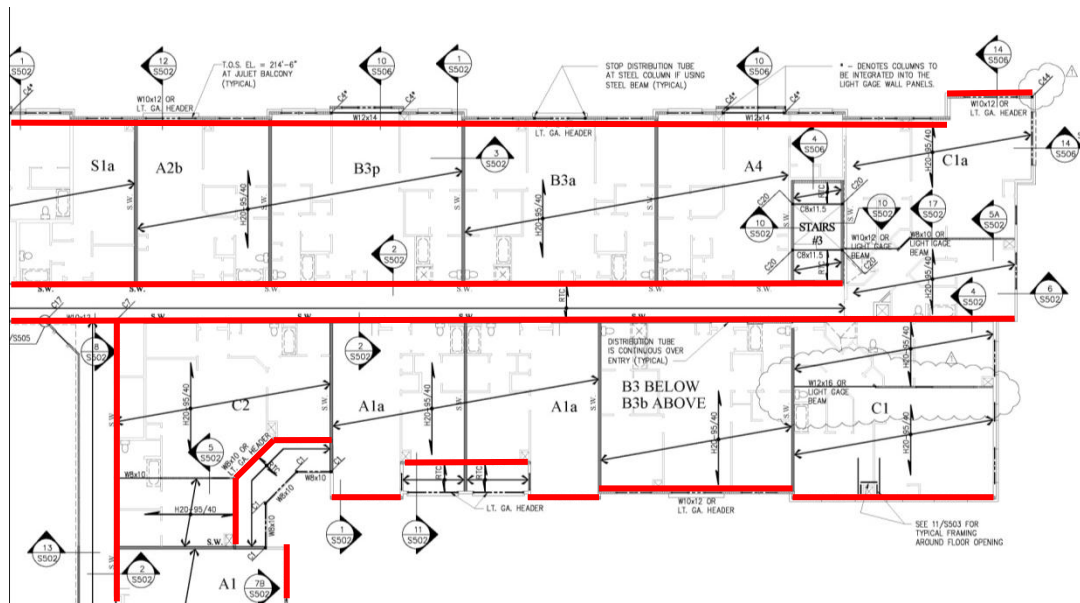
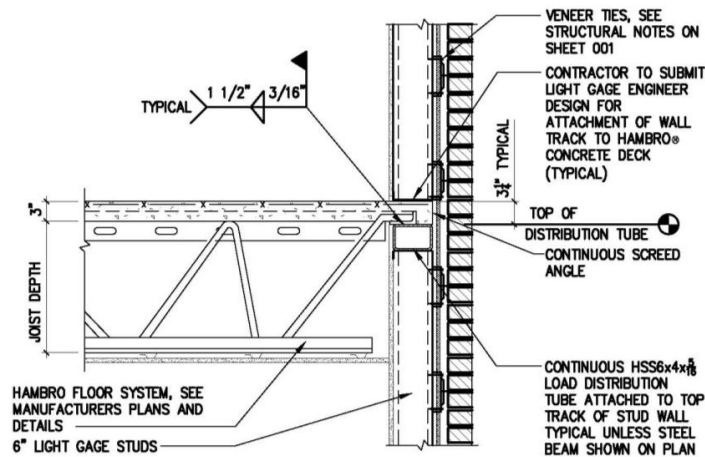

Figure 6: Location of bearing walls. (Construction documents by Cates Engineering).

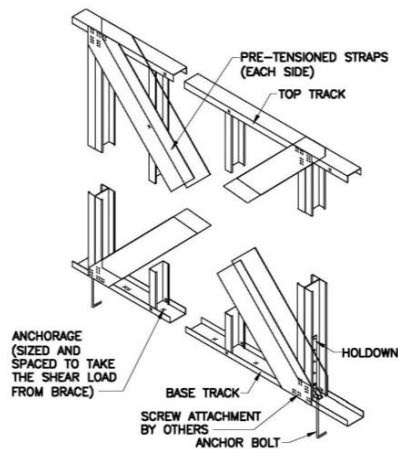



**Figure 7: Exterior wall framing details. (Construction documents by Cates Engineering).**

### Lateral System

The lateral system in the Residence is a light gage shear wall system designed and engineered by The Steel Network Company. The system utilizes light gage 50 ksi steel hot dipped galvanized coated straps on both sides of the wall for shear resistance. A 6" wide flat strap is used in the lateral system of the Residence. (See figure 8 for a typical framing detail). The shear walls are located all throughout the building (figure 9), with most of the shear wall located in the corridor walls and the walls separating adjacent apartments.



**Figure 8: Lateral resistance system. (Construction documents by Cates Engineering).**

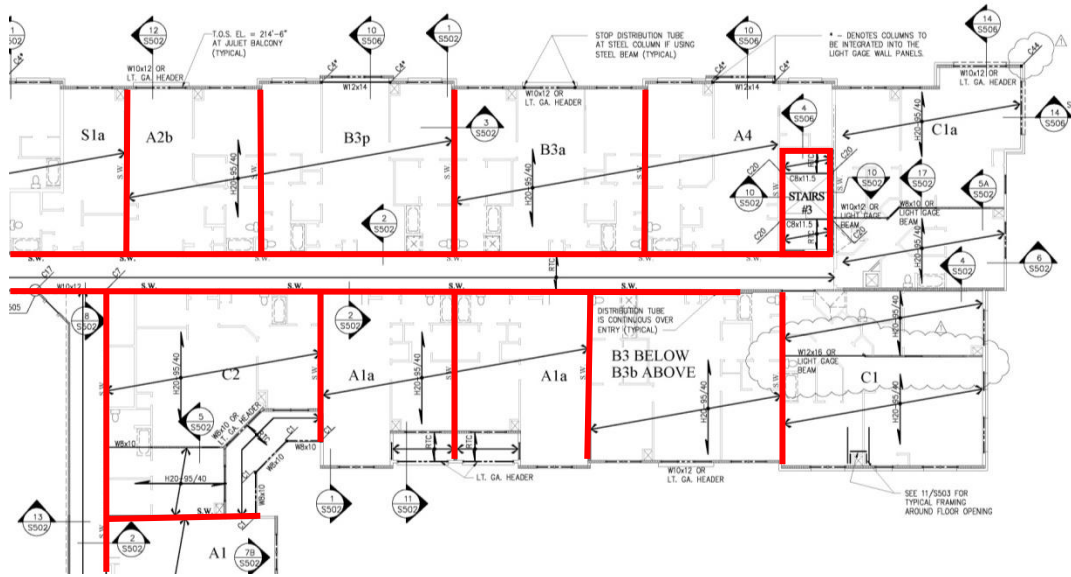

Figure 9: Location of the shear walls. (Construction documents by Cates Engineering).

### Roof System

The roof system is the same, Hambro system, which is used for the floors throughout the building. The roof slab is 3" thick 3,000 psi concrete with 6 x 6 W2.9 x W2.9 welded wire fabric, and is supported by a 20" deep Hambro joist.

## **Proposal**

### **Proposed Structural Depth**

The Residence is designed as a light gage metal studs bearing and shear walls which supports the Hambro floor system. In the analysis of the existing conditions of The Residence it is found that the building did meet all requirements. For the purposes of this thesis The Residences will be re-evaluated using a One Way and Two Way concrete floor system and different lateral systems.

The concrete system will be designed to support the gravity loads determined in the early technical reports. The existing building layout is used as a template to start the design process; some variations may need to be implemented upon further analysis of the redesign. After the initial design is accomplished the lateral loads will be determined and the lateral resisting systems will be designed.

The lateral loads will be determined for the current location of the building and a location in a high seismic region, pending the acquiring of a Geotechnical report from a high seismic region. Once the loads are determined the lateral resisting systems will be designed. It is planned to performed research and design of concrete shear walls, seismic resisting dampers, and base isolation systems to resist the later loads. A 3D model is used to model the gravity and later system to aid in the design of the members and verify the accuracy of the design.

## Breadth Options

### *Breadth Study One: In-Depth Cost and Schedule Impacts of Depth*

The first breadth study was chosen with its connection to the structural depth. The proposed changes to the floor system, superstructure, and lateral system will have an impact on the scheduling and cost of the building such as the scheduling changes that would involve the additional forming, placing, and shoring of the concrete. Once the scheduling impact and cost changes are considered, the feasibility of redesigning The Residence as concrete system will be evaluated.

### *Breadth Study Two: Sustainability*

To achieve a sustainable building, a green roof is going to be considered in place of the current rooftop. The design of the green roof is to consist of a study of the layers that make up the system and the flashing and membrane involved. Also, the green roof is to be designed with the intention of retaining water that can be used throughout the building. The drainage and flow of water to a central gray water collection tank is to be considered and designed. In addition, the hope is that the green roof will be accessible to the building's occupants, thus access to the green roof is to be provided. Finally, the loads from the green roof will be applied to the design of the gravity and lateral system.

### *Breadth Study Two Alternate: Lighting Study of Typical Apartment.*

Should the sustainability breadth fail to meet the requirements as a breadth, the lighting of a typical apartment will be redesigned. The challenge is to redesign the lighting to be both aesthetical pleasing but also functional in allowing various lighting conditions. The use of high efficient lamps and luminaires will also be considered.

## Tasks and Tools

Listed below is a list of tasks to be completed in the research and development of the proposal as well as the required tools.

### Task 0

- Determine the gravity loads to be used in the design.
- Establish the location of column grid.

### Task 1

- Create 3D computer model to aid in the design of concrete framing.
- Design the One-Way Concrete Slab floor system.
- Design the Two-Way Concrete Slab floor system.

### Task 2

- Determine lateral loads for current location and high seismic region.
- Equivalent lateral force method.
- Modal Response Spectrum Analysis method.

### Task 3

- Research of seismic resistive systems; Shear walls, Dampers, and Base Isolation.

### Task 4

- Design seismic resistive system for the current location.
- Design seismic resistive system for the high seismic region.

### Task 5

- Using RS Means to obtain a preliminary cost and schedule of redesign.
- Consult with the general contractor for a detail cost analysis and schedule of current design.

### Task 6

- Research of the components and design of a green roof.

### Task 7

- Design the components, layers, flashing, and membranes of a green roof.

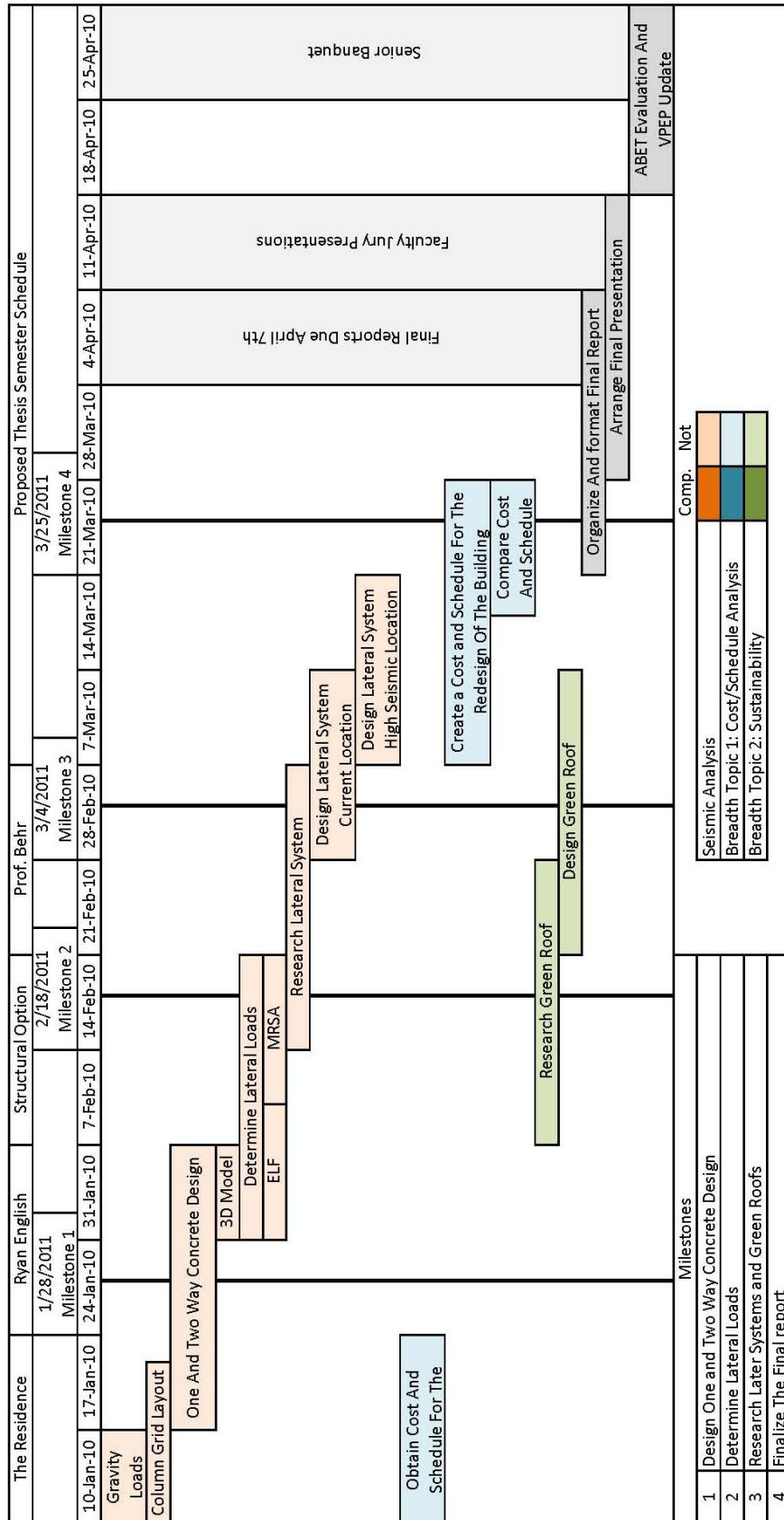

## Conclusion

The Residence is designed as a light gage metal stud bearing and shear walls which support the Hambro floor system. This thesis proposal is to pursue the development of concrete and seismic resistive systems and implement that design to The Residences. The Residence is to be redesigned with a concrete superstructure.

The floor system is to be redesigned using concrete system. A One-Way and Two-Way concrete floor system is to be investigated and design for the building. The new floor system is to cause a change in the seismic loading on the building. The lateral load is to be determined using the equivalent lateral force method and modal response spectrum analysis as prescribe in ASCE7-05 for the current location and a high seismic region.

Once the lateral loads are determined a study of alternative seismic resistive systems is to be performed. Research is to be conducted on the use of shear walls, dampers, and base isolation systems. The lateral loads of the building are to be resisted by the use of the best system that is found from the research of the seismic resistive systems.

The change to a concrete system leads to other changes throughout the project. An in depth cost analysis and schedule impact study is to be performed to determine the changes that are due to the changes in the structural system. The scheduling changes that would involve the additional construction time for the formwork and placement of the concrete.

To achieve a sustainable building, a green roof is to be design instead of the current roofing system. The design of the green roof is to consist of a study of the layers that make up the system and the flashing and membrane involved. Also, the green roof is to be designed with the intention of retaining water, the drainage and flow of water to a central gray water collection tank is to be considered and designed. The loads from the green roof will be applied to the design of the gravity and lateral system.