

**DRAFT**

# HEIFER INTERNATIONAL CENTER

LITTLE ROCK, ARKANSAS

## TECHNICAL REPORT I

Sikandar Porter-Gill | Structural Option

Advisor: Dr. Thomas Boothby

September 13, 2013



Photo Credit: Timothy Hursley



**DRAFT**



## Table of Contents

Executive Summary .....	4
Purpose .....	5
Building Overview .....	5
Structural Systems .....	7
Structural System Overview .....	7
Foundation System .....	7
Geotechnical Report .....	7
Foundation Design .....	8
Water Tower Mat Foundation .....	9
Gravity Systems .....	10
Floor System .....	10
Framing System .....	12
Roof System .....	13
Lateral System .....	14
Joint Details .....	16
Bolted Connections .....	16
Moment Connections .....	16
East and West End Balconies .....	17
Seismic Joint .....	18
Design Codes and Standards .....	19
Materials .....	20
Concrete .....	20
Steel .....	20
Other Material .....	20
Determination of Design Loads .....	21
National Code for Live Load and Lateral Loads .....	21
Gravity Loads .....	21
Live Loads .....	21
Dead Loads .....	21
Snow Loads .....	21
Rain Loads .....	21
Lateral Loads .....	21



Wind Loads ..... 21

Seismic Loads..... 21

Load Paths ..... 21

    Gravity Load Path..... 21

    Lateral Load Path ..... 22

Conclusion..... 23



## EXECUTIVE SUMMARY

This technical report provides a structural summary of Heifer International Center, located in Little Rock, Arkansas. The Center was one of the few Platinum Certified LEED Buildings in the Southern United States. The mostly glass building is semi-circular, at 440'-0" in length and 62'-0" wide. Various joint connections are used throughout the building, including shear and moment connections, and several special connections due to the shape of the building.

Due to the complexity of the existing site's soil conditions a Rammed Aggregate Pier<sup>®</sup> System by Geopier Foundation Company, Inc. was used in conjunction with a slab-on-grade, piers, footings and grade beam system. This foundation system supports a system of HSS steel pipes. The office building was designed as a composite concrete-steel floor system, with additional reinforcement in the concrete slab is reinforced to mitigate cracking that occurs over the steel girders.

The lateral system employs a Steel Plate Shear Wall at several locations throughout the building, which utilizes large shear plates and welded C-channels. Due to the length of the building, Heifer International Center is divided into two fairly even sections. This system effectively acts as two separate structures that are linked together with a special seismic joint that prevents the two structures from colliding in event of an earthquake..

Heifer International Center was designed in accordance with the IBC 2000, which references the load provisions of ASCE-7 1998. Special consideration was given to the large inverted roof—for both uplift and for excessive snow loads due to drifting. The large water tower collector was specifically designed for large uplift forces, and a different foundation system was used for this section—a 2'-0" thick mat foundation.

The following report discusses each structural system in detail, loads used in the design and codes, standards and regulations that controlled its design and construction.

## PURPOSE

The emphasis of this technical report is to describe the existing conditions of Heifer International Center, located in Little Rock, Arkansas. This report includes descriptions of the foundation system, gravity system, and lateral systems, and also focuses on codes and materials used in the building’s design and construction. Moreover, a discussion of the loads used in the building’s design is available later in this report.

## BUILDING OVERVIEW

Heifer International’s headquarters emulates Heifer’s goal of reaching out to a community in need. Heifer wished their headquarters to match what they were teaching to the world. The shape of the building and campus were inspired by Heifer International’s founder Dan West who expressed, “In all my travels around the world, the important decisions were made where people sat in a circle, facing each other as equals.” This was extended to show the ripple effect Heifer has on needy communities, through their donation of livestock. These communities agree to pass on the offspring of the animal to others—thus creating a ripple effect throughout the community.



Figure 1 | Exterior view of Heifer International Center

The building has an open floor plan that allows natural light to penetrate to the center of each level, provides views of the river and cityscape, and offers extensive community exchange points with easy access to exterior balconies on each level. Heifer International Center continues Heifer’s mission of teaching—the public is allowed access to the facility through tours provided by Heifer personnel, showcasing the sustainable features of the office building. Heifer International Center is 98,000 square feet, spread out over 4 floors. It stands 65 feet in overall height and was constructed between February 2004 and January 2006, at a cost of approximately \$18 million.



Figure 2 | Interior view of Heifer International Center

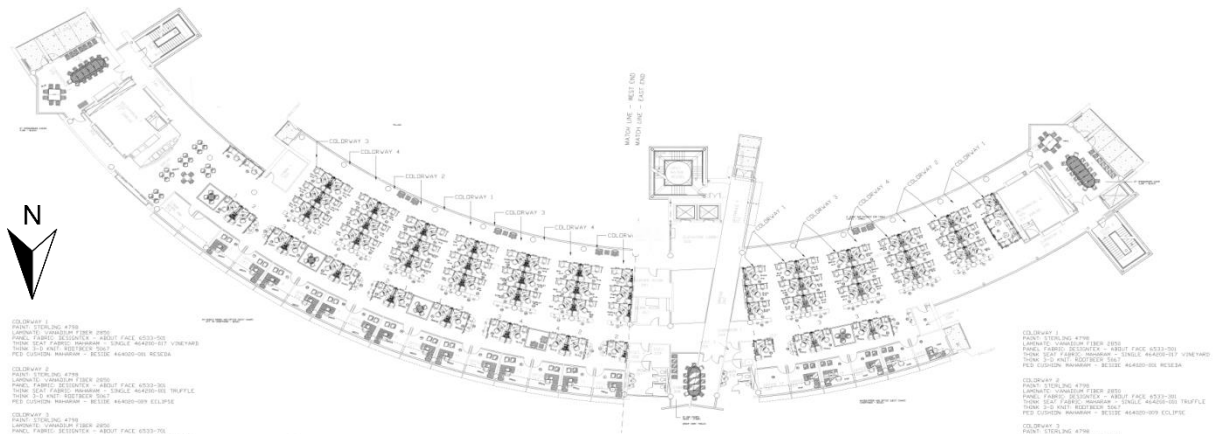


The design team from Polk Stanley Wilcox Architects and Cromwell Architects Engineers, Inc. were faced with the large challenge of providing an open office plan, in a semi-circular shape, while concurrently offering sustainable features that would express Heifer International’s mission of ending world hunger and poverty.

A unique feature of the building includes the use of a custom tree-column design that is used to support the inverted roof at both exterior and interior points. The roof is inverted for two reasons. The first is to direct rainwater toward the large silo-tower for storage and greywater use. The second is to provide the ideal angle for a possible future solar panel array.

Heifer International Center was placed in an industrial section of Little Rock that is currently being revitalized. This led to many advantages that the design team used to the building and site’s benefit. The site that Heifer International Center occupies was contaminated with industrial waste. Through land reclamation, the soil was removed from the site and taken to a facility to be treated and used elsewhere in the Arkansas region. The industrial section of the city also housed the steel mill that manufactured Heifer International’s steel structure—AFCO Steel Inc. is located only a few blocks away from Heifer’s site. Moreover, the mostly glass-clad building is built using Ace Glass Co Inc. as the fabricator of the glass, located less than a 100 yards from the building.

Below is a typical floor plan of Heifer International Center.



**Figure 3** | Typical Floor Plan (HIC CD Furniture Plan)

Heifer International achieved LEED Platinum Certification using the building’s unusual shape to capture natural light, store water for future use and also distribute air more efficiently.

## STRUCTURAL SYSTEMS

This section of the report provides an overview of Heifer International Center’s structural systems, codes used by the design team and other materials and details that were specified during the design phase of the project.

### STRUCTURAL SYSTEM OVERVIEW

Heifer International Center is a four story steel structure that is laterally supported by steel plate shear walls. The floor system is a composite decking system, which is supported with large HSS pipes for the framing system. The framing system bears onto a system of piers and footings. Grade beams also bear onto the system of piers and footings but instead support the slab-on-grade. A section of the Ground Level is recessed into the ground 2’-0” to accommodate a larger mechanical room.

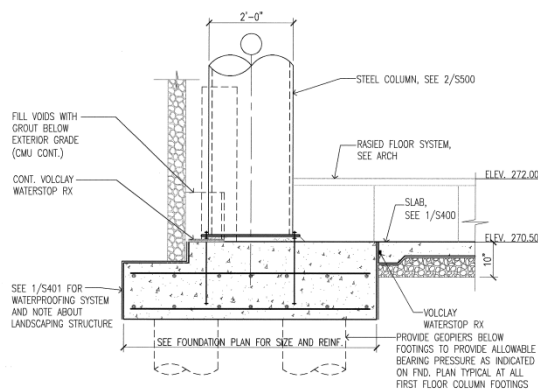
### FOUNDATION SYSTEM

#### Geotechnical Report

Grubbs, Hoskyn, Barton & Wyatt, Inc. performed a geotechnical survey of the site in January of 2003. The survey encountered expansive clays on the east side of the building and soft and compressible soils on the west side of the building. Expansive clays expand when they gain water, and contract when they lose water—potentially heaving, or raising, the site elevation 4” to 8”. On the east side, the report recommended that the weak soils should be undercut during site grading—approximately 4’-0” to 6’-0”. Undercutting involves removing the soil to the specified depth and replacing it with engineered soil, which is compacted. The soil removed would be replaced with low-plasticity clayey sand, sandy clay or gravelly clay. The geotechnical engineer stated that undercutting would allow the use of a slab-on-grade system; however, the use of two potential systems to increase the bearing capacity of the soil would have to be implemented.

The geotechnical engineer recommended either Rammed Aggregate Piers or Drilled Piers, for the foundation system. A Rammed Aggregate Pier<sup>®</sup> (RAP) System by Geopier Foundation Company, Inc., is used to mechanically improve the soil conditions of the site. The RAP system uses “vertical ramming energy” to add layers of crushed aggregate

to the site. Generally, Geopiers<sup>™</sup> are formed by drilling 30-inch diameter holes and ramming aggregate into the hole, until a “very stiff, high-density aggregate pier[s]” are formed. This crushed aggregate increased the soil’s capacity to between 5 to 7 ksf for the Heifer International Center. Additional Geopiers<sup>™</sup> were provided per structural drawings, due to larger loads or the higher potential for uplift at certain sections of the building. The



② STEEL COL. BRG. AT EXT. FOOTING ON GRID LINE C  
3/8"=1'-0"

Figure 4 | Section of footing supported by

geotechnical engineer stated, “Total settlement of shallow footings on Geopier™ elements would be expected to be less than about 1.0 inch and differential settlement less than about 0.5 inch.”

A Drilled Pier Foundation system, a second recommendation by the geotechnical engineer, is a particular type of caisson used to provide high column load capacity; however, the piers do not penetrate as far into the ground as a normal caisson. The size of the drilled pier can range from 2’-0” to 10’-0”, and would support structural grade beams and/or columns. For the drilled piers to work properly, drilling would have to continue down to the “brownish gray clay... at a depth of 30 ft below the existing grade.”

The geotechnical report tabulated Equivalent Fluid Pressures for the site. These values are summarized below and will be used later in the design phase of the project.

Earth Pressure Condition	Free-draining crushed stone (PCF)	Low-plasticity select clayey sand backfill (PCF)
At rest, drained	50	65
At rest, undrained	85	95

**Foundation Design**

The design teams chose a RAP® System, which allowed the use of conventional slab-on-grade, footings and grade beams. The RAP® System had the added benefit of increasing the bearing capacity and decreasing the size of the footing. Figure 4 on the previous page shows a typical column supported by a footing, which in turn distributes its loads to the soil that has been engineered to carry more load due to the RAP® System.

This system was applied to the entire building footprint. Both a typical and sloped slab-on-grade were used, shown in Figure 5, and are reinforced with welded wire fabric.

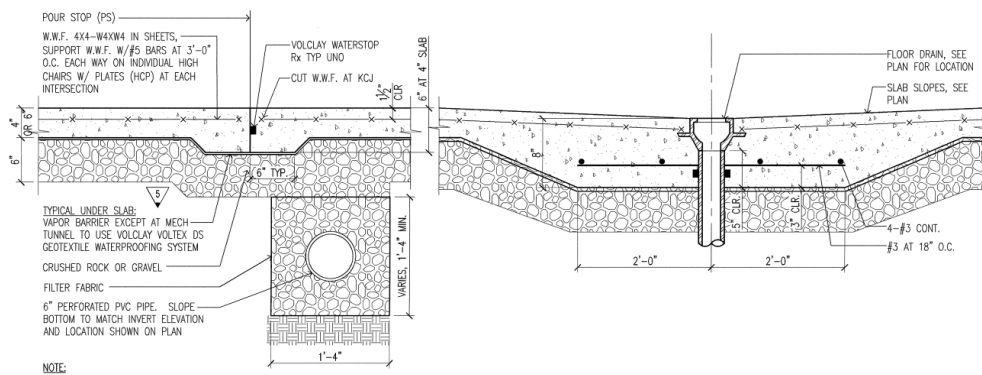


Figure 5 | Slab-on-grade details: Right—typical slab-on-grade, Left—sloped slab-on-grade (Drawing 1B/S400 and 1C/S400)



The slab-on-grade fluctuates in depth at many locations due to various loading conditions used throughout the building. Figure 6 below summarizes the depth of the slab-on-grade.

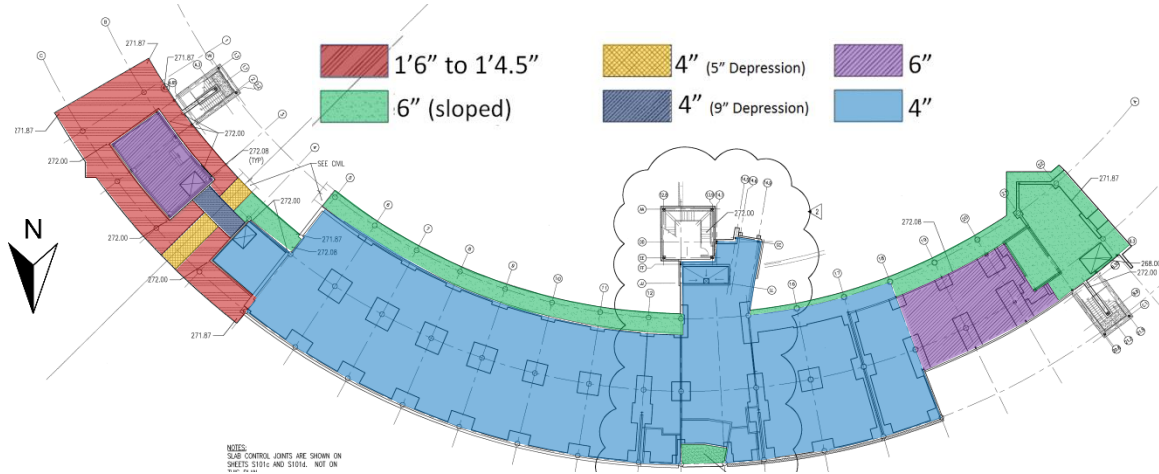


Figure 6 | Depth of slab-on-grade varies throughout the Heifer International Center (Drawing 2/S002)

Heifer International Center also is provided with grade beams to distribute loads to column piers and footings. These grade beams support the slab and prevent the slab from deflecting or settling. The design uses various sizes of grade beam, which are reinforced using #4 stirrups at 24" O.C.; #5 and #8 longitudinal reinforcing bars are also used.

### Water Tower Mat Foundation

The water tower's foundation system was oversized using a 3'-0" mat foundation. The soil underneath was also prepared using the RAP<sup>®</sup> System and the design of the footing also considered overturning of the water tower.

## GRAVITY SYSTEMS

### Floor System

Heifer International Center’s floor system is composed of girders and beams supporting composite steel deck filled with a concrete slab. The greater part of the beams supporting the floor system are W14x22s and W16x26s. Each beam has a camber ranging from 3/4” to 1”. The framing nearer the center of the building is irregular due to the large interior architectural opening, walkway bridge and lobby space. The framing at each end of the building, on the east and west, is also irregular due to the large mechanical spaces, cantilevered balconies and stairwells. The mechanical spaces are generally supported by W16 beams..

Each floor of the Heifer International Center has a similar layout to that shown in the half-plan in Figure 7 below

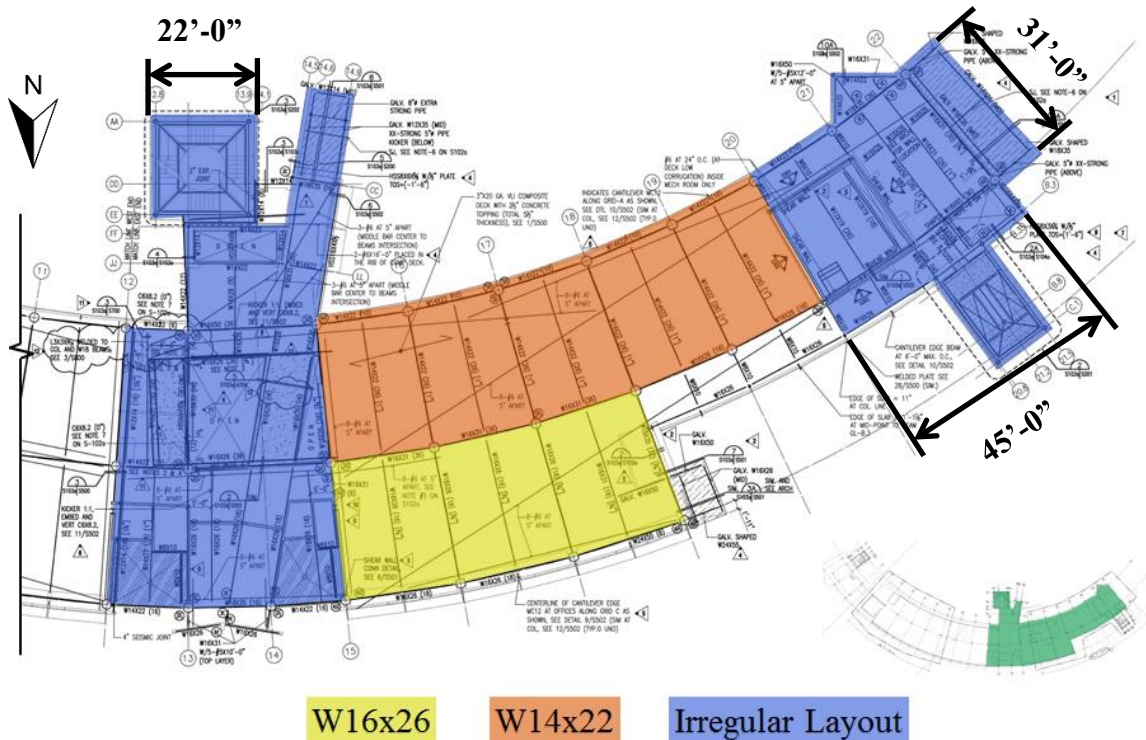
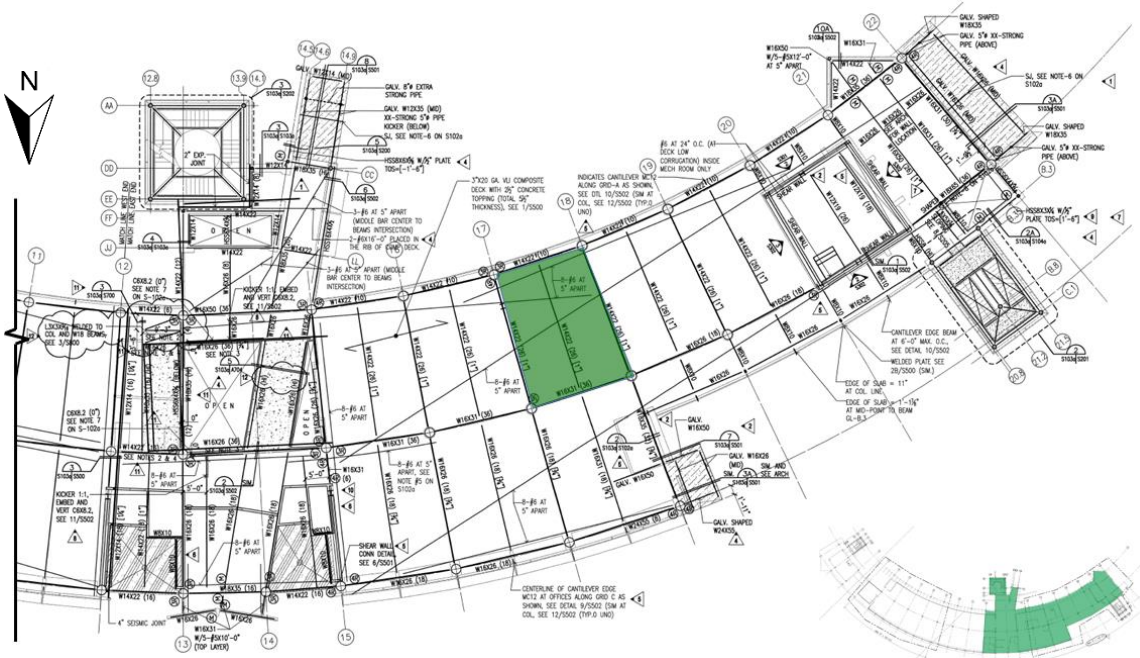


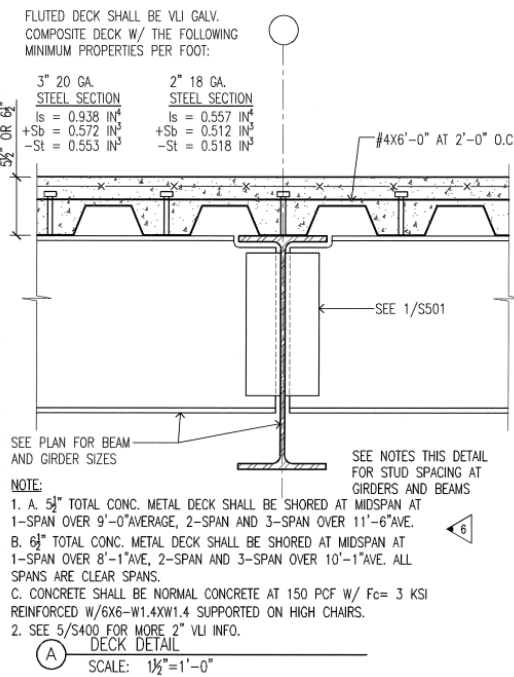
Figure 7 | Comparison of typical framing layout (yellow and orange) to irregular framing layout (blue), with a few general building dimensions (Drawing 1/S102a)

A typical bay, on Level 2, between column lines A/B and 17/18 will be fully described below. This bay is highlighted in the [Figure 8](#) below.

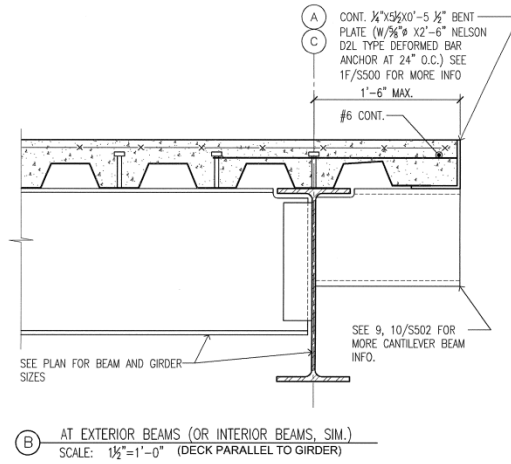


**Figure 8** | Typical bay to be fully explained (Drawing 1/S102a)

A typical bay is 20'-0" x 30'-0", where the floor is supported by a system of beams and girders. The beams and girders collect the loads of the 3VLI 20 gauge composite deck with 2 1/2" of normal weight concrete topping for a total thickness of 5 1/2". The decking compositely acts with the framing members to take advantage of concrete in compression and steel in tension. A detail showing the composite deck configuration with a wide-flange is shown in [Figure 9](#). In addition, at the edges of the building (or the interior sections that are open to below) the composite deck is ended with a bent edge plate, shown below in [Figure 10](#).



**Figure 9** | Interior composite decking detail (Drawing 1A/S500)



**Figure 10** | Edge composite decking detail (Drawing 1B/S500)

It should be noted that all of the floor slabs, although they are supported by the composite decking, are also reinforced with #4 at 6” O.C. in order to control cracks that occur naturally over the girders. This cracking occurs when the slab tries to take tension to make the beam continuous over the girder. A reason for the insertion of this reinforcement is to reduce the magnitude of the deflection occurring at each level due to the use of under-floor air distribution plenums for the mechanical system.

**Framing System**

The framing system consists of large round HSS shapes, which continue from the ground level to the fourth floor. Originally concrete columns were considered; however, the contractor and steel fabricator were particularly concerned about tolerances maintaining tolerances on concrete columns, and the attendant difficulty of connecting to the beams. Due to these concerns, the design was changed to round steel, HSSs, which vary from 10” to 24”. A photograph of the HSS during the erection process is shown in [Figure 11](#).

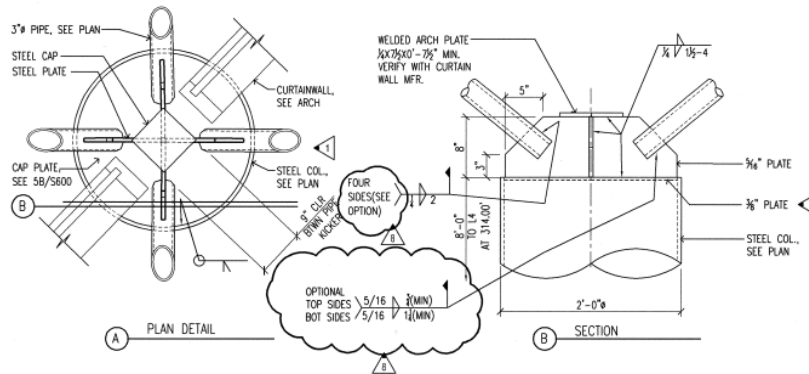


**Figure 11** | Photograph during erection of HSS framing



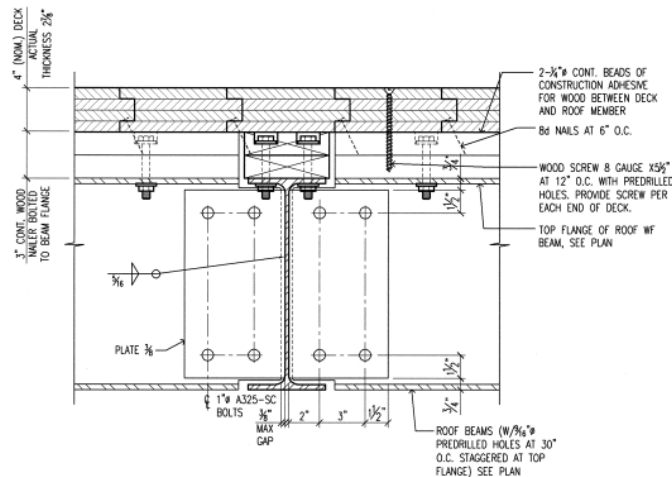
### Roof System

The roof-framing plan varies from the floor framing plans—due to the tree-column designs that flare out on the fourth level and attach to the roof girders. These girders support steel beams, which in turn support a timber wood roof deck. The roof cantilevers approximately 8'-0" beyond the edge of the building, while simultaneously inverting the roof to form a valley. A Thermoplastic Membrane topped with a 4" Glued laminated wood decking makes up the first two layers of the roof, [Figure 12](#). The wood decking has a tongue-and-groove, and is connected to 3" of continuous wood lumber using 8d nails at 6" O.C. This system is bolted to the top flange of the roof steel members. The flare connection detail is shown below in [Figure 12](#), which supports the roof system shown in the section detail of [Figure 13](#).



5 TYPICAL FLARE-OUT PIPE SUPPORT DETAIL  
1/8" = 1'-0" 11"

[Figure 12](#) | Roof tree-flare connection detail  
(Drawing 5A/S600 and 5B/S600)



1 TYPICAL WOOD DECK CONNECTION DETAIL  
3" = 1'-0"

[Figure 13](#) | Detail of roof framing connection to timber (Drawing 1/S600)



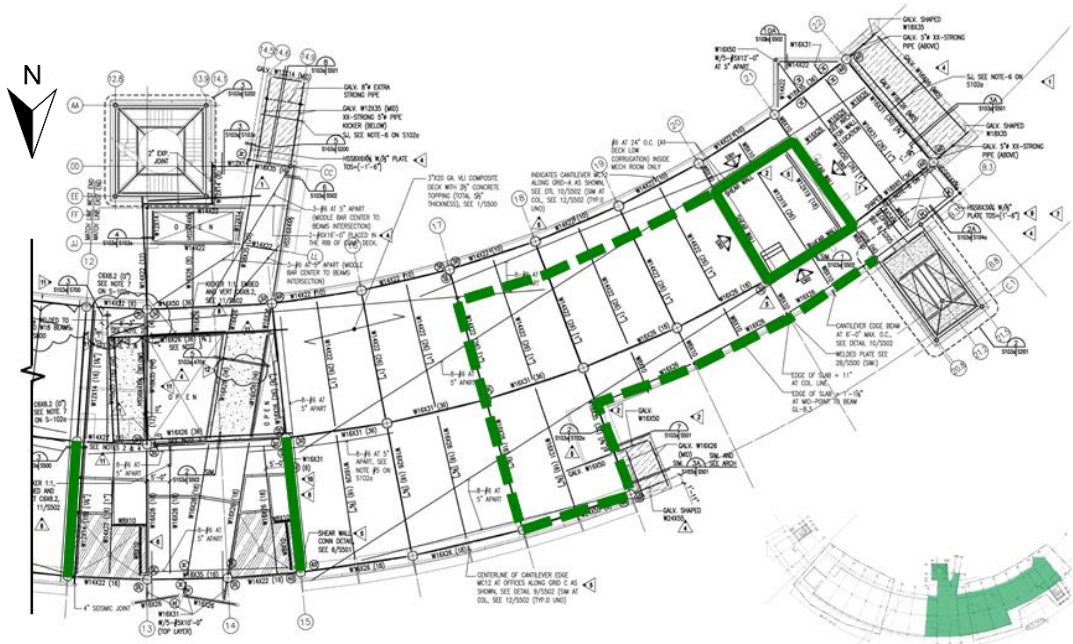
**LATERAL SYSTEM**

Lateral stability is ensured in part by the floor deck, which acts as a diaphragm spanning between steel plate shear walls. Steel plate shear walls (SPSWs) resist horizontal shear, and effectively act as a vertical girder—the columns act as the flanges and the steel plate acts as the web. The SPSWs span from the foundation to the bottom of the fourth floor. The floor slab is also reinforced with additional #6 at 5” O.C. to help with diaphragm action of lateral loads. According to the design team, this reinforcement is very important around floor openings.

Lateral loads at the roof are collected by the roof deck diaphragm and then transferred to the round steel columns, passing through the flare out connections of the tree-columns. This lateral load from the columns is transferred to the fourth floor diaphragm, which in turn is collected by the SPSWs.

Due to the irregularities of the building’s shape and the 440’-0” length, the semi-circular building was divided into two approximately even sections with a seismic joint. These two halves were analyzed separately for lateral loads, using both static and dynamic methods. Essentially, two separate structures, with separate lateral systems, are joined together to act as one unit.

Figure 14 below shows a layout of the SPSWs, both for continuous SPSWs that span the ground floor to the fourth floor, and the SPSWs that only span the ground level, around the mechanical room.



A typical SPSW is shown in Figure 15, which shows the continuous shear plates that are installed into the wall system. For clarity, the shear plates are shown in red, in both section and plan. These plates are reinforced with C-channels spaced at 24" O.C., welded perpendicular to the shear plates attached to the wall. The C-channels are shown in blue in Figure 15 below. The wall is approximately 6" thick, with an added CMU back wall.

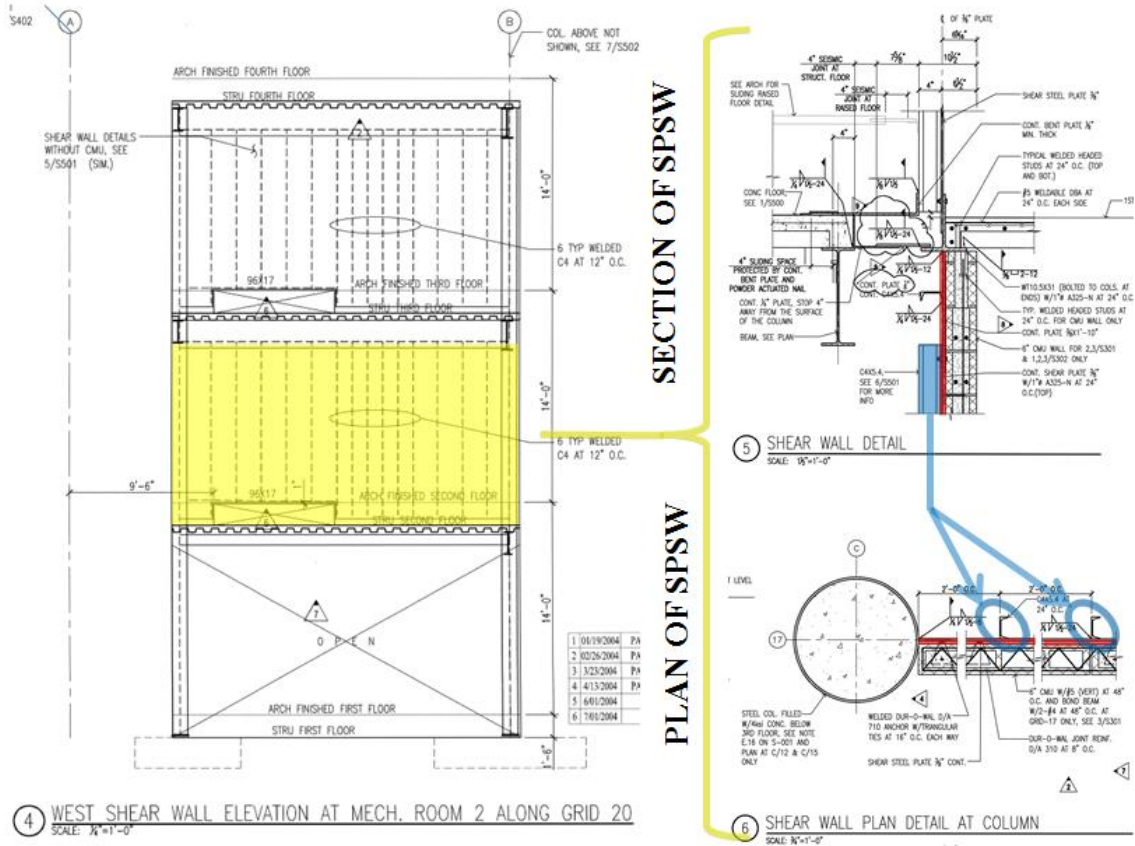
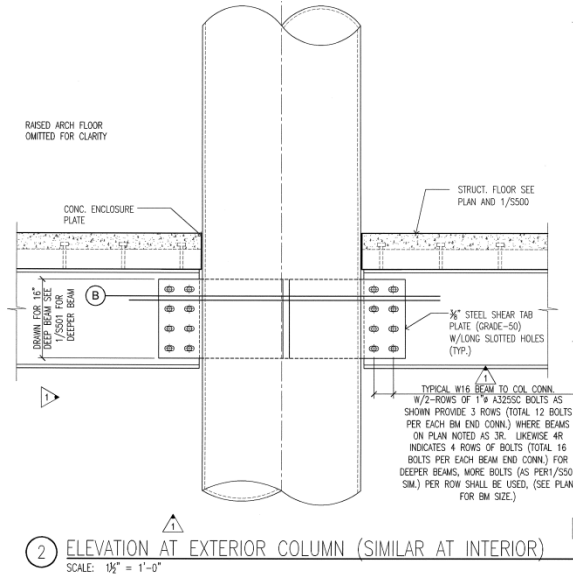


Figure 15 | Typical SPSW elevation, section and plan (Drawing 4/S302, 5/S501 and 6/S501)

## JOINT DETAILS

### Bolted Connections

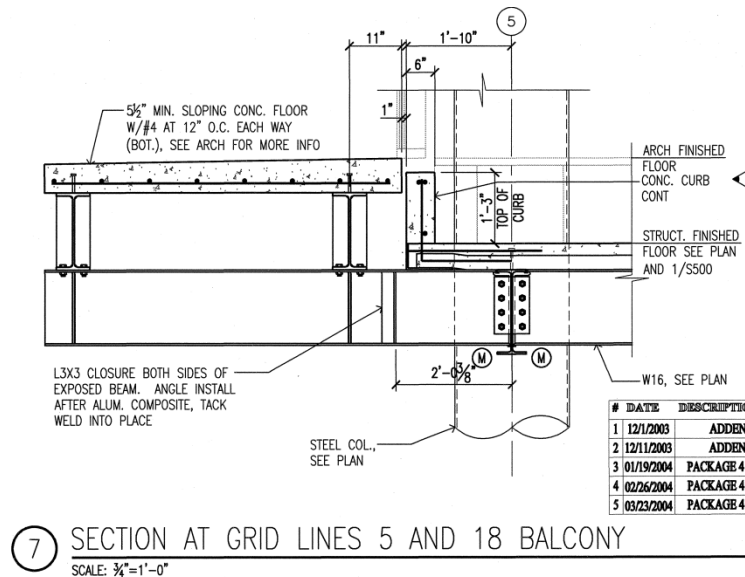
Most of the connections are shear connections in Heifer International Center, and are bolted in three or four rows. This is shown in [Figure 16](#) below.



[Figure 16](#) | Typical shear connection (Drawing 2/S500)

### Moment Connections

Small cantilevered balconies are anchored to the building using moment connections, which is shown in [Figure 17](#).



[Figure 17](#) | Typical moment connection supporting balconies located on each level (Drawing 7/S501)

### East and West End Balconies

Heifer International Center has large balconies on the east and west that use a shear connection to attach to the building. These balconies are also supported by tension members, HSS pipes. Figure 18 shows a detail section of how the balcony is supported by the shear connection and pipes.

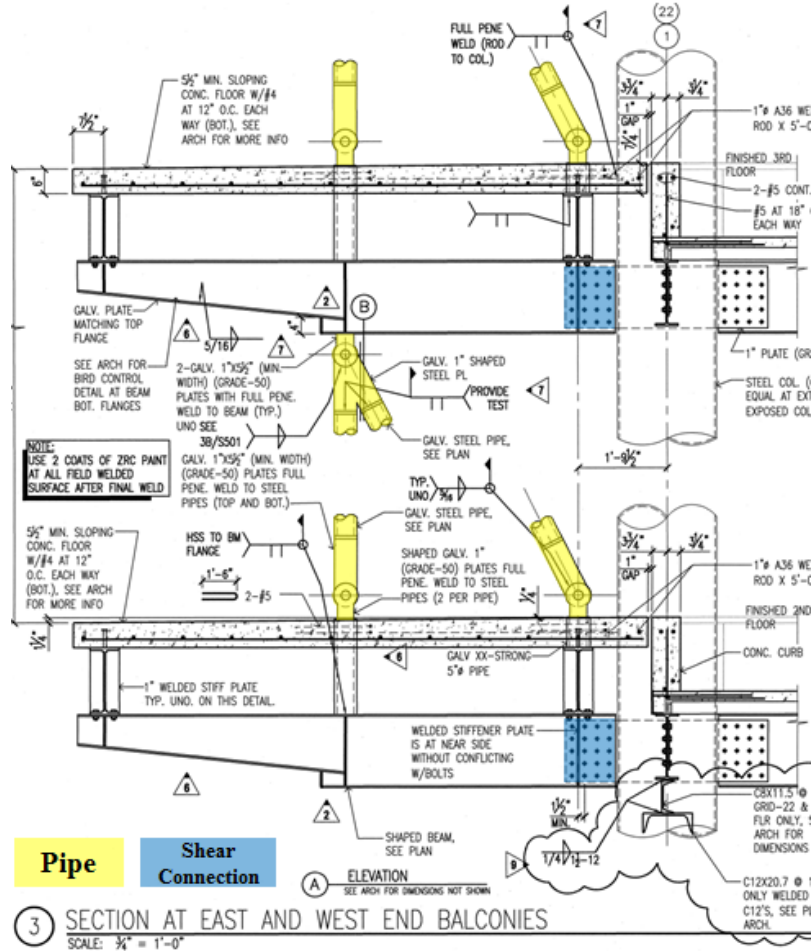
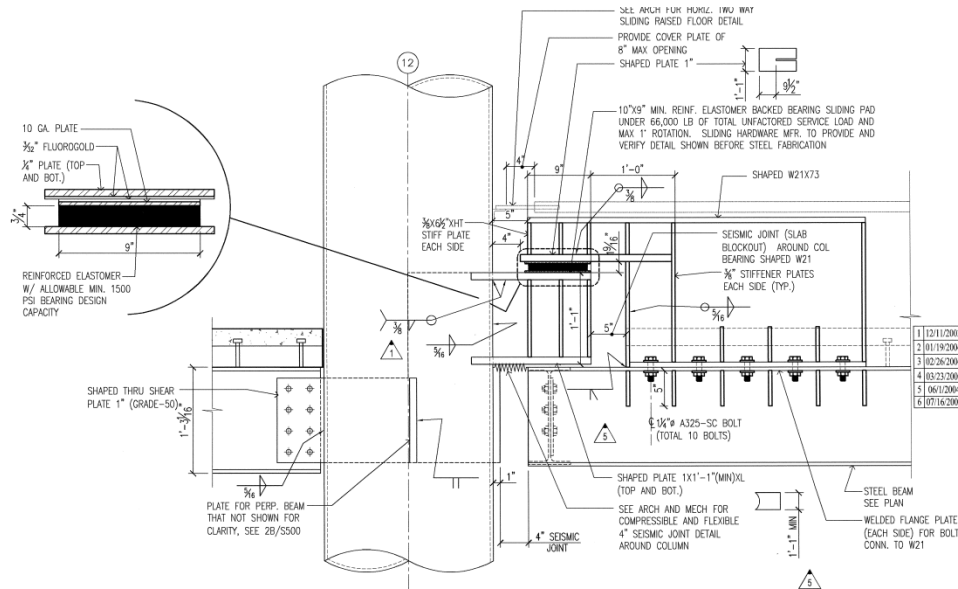


Figure 18 | Typical balcony section showing shear connection and pipes (Drawing 3/S501)

### Seismic Joint

Due to Heifer International Center’s semi-circular shape and the extreme length of the building, a seismic joint was installed at each level between the second and fourth stories. A seismic joint is placed between the abutment of the two halves of the building—in order to moderate damage during an earthquake. A seismic joint is similar to an expansion joint; however, it can accommodate movement in both perpendicular and parallel directions. The design for the seismic joint used at each level is shown in [Figure 19](#).



3 COLUMN TO BEAM CONNECTION AT SEISMIC JOINT  
SCALE: 1/2" = 1'-0"

**Figure 19** | Seismic Joint detail (above) and photograph (below)  
(Drawing 3/S500)







## DESIGN CODES AND STANDARDS

The following section lists the codes and design guides used in Heifer International Center, as well as local regulations that supplemented these codes and standards.

### International Code Council

International Building Code 2000 (with Little Rock, Arkansas local amendments)

### American Society of Civil Engineers

7-1998: Minimum Design Loads for Buildings and Other Structures

6-1999: Specifications for Masonry Structures

### American Concrete Institute

318-95 and ACI 318-99: Building Code Requirements for Structural Concrete

### American Institute of Steel Construction

Manual of Steel Construction: LRFD, 2<sup>nd</sup> Edition

### Arkansas Act 1100 of 1991

Earthquake Structural Requirements for Arkansas

### American Welding Society

D1.1-98, Structural Welding Code – Steel

D1.3-98, Structural Welding Code – Sheet Steel

D1.4-98, Structural Welding Code – Reinforcing Steel



## MATERIALS

Heifer International Center used the following materials. Their respective stress and strength properties are provided below.

### Concrete

	Minimum Strength (ksi)	Air Entraining	Water Reducing Admix Required
Reinforced Footing	3	None	Yes
Reinforced Walls, Grade Beams and Columns	4	5% AIR	Yes
Interior Slab on Grade	3	None	Yes
Typical Floor Slab	3	None	Yes
Walkway	3	5% AIR	Yes
Precast Column, Plank	5	5% AIR	Yes

### Steel

Shape	ASTM	Grade	Fy (ksi)
Beams and Girders	A992 or A572	50	50
Hollow Round Columns	A252	3	45
Columns	A992 or A572	50	50
Tube Members	A-500	B	46
Plates	A-36	5% AIR	36
Misc. Steel	A-36	None	36
Connection Bolts	A325-SC	-	-

### Other Material

Material	ASTM	Notes
Concrete Masonry Units	C-90	Lightweight, Type I Moisture Controlled $f'_m = 1500$ psi
Mortar	C-270	Type S $f'_m = 1800$ psi
Grout		$f'_c = 2500$ psi
Reinforcing Bars	A-615	Fy = 60



## DETERMINATION OF DESIGN LOADS

This piece of the report reviews the loads used in the design of Heifer International Center, and other local Arkansas laws that influenced the design and construction.

### NATIONAL CODE FOR LIVE LOAD AND LATERAL LOADS

Live Load	ASCE-7 1998 Chapter 4
Wind Load	ASCE-7 1998 Chapter 6

### GRAVITY LOADS

#### Live Loads

Live loads used in the design of Heifer International Center were referenced using ASCE-7 1998 Chapter 4.

#### Dead Loads

Dead load allowances were assumed for the typical floor at 95 PSF and roof at 30 PSF. The 95 PSF floor load takes into account the composite decking, potential ponding of concrete, computer technology, mechanical and sprinkler infrastructure.

### SNOW LOADS

Ground snow loads for Pulaski County Arkansas are 10 PSF, according to ASCE-7 1998 Chapter 7; however, the timber roof loads increased the design load to 30 PSF due to the high possibility of snow drift into the valley of the roof.

### RAIN LOADS

Rain loads were calculated for Heifer International Center using ASCE-7 1998 Chapter 8.

### LATERAL LOADS

#### Wind Loads

Loads due to wind were calculated using ASCE 7 1998 Chapter 6. The design team used an Exposure Category C (§ 6.5.6.1), with a 90mph wind speed.

#### Seismic Loads

The geotechnical report states that the "...site is located in Seismic Zone 1," according to the Pulaski County Arkansas State criteria—an "area of low anticipated seismic damage." The design team referenced ASCE-7 1998 Chapter 9 and the Arkansas Act 1100, Zone 1, of 1991.

### LOAD PATHS

#### Gravity Load Path

The composite deck will carry a load on a floor and transfer it to the beams and girders framing each level. As the floor system collects the load, the load is shifted to the framing system composed of large HSS pipes. This is transferred down to the ground level and is resolved onto piers, footings and grade beams.



The foundation system dissipates this load into the soil that has been engineered using Geopier™ technology.

Roof loads follow a similar path, except the roof diaphragm is composed of wood timber instead of a concrete composite deck. The timber transfers the loads to steel beams and girders, which in turn distribute the loads to tree-column connections. These intricate connections dissipate the energy down to the foundation using the large HSS pipes that compose the framing system.

### **Lateral Load Path**

The façade of the building picks up the distributed load of the wind and transfers this to the floor diaphragm. The steel plate shear wall collects this horizontal force from the diaphragm and generates a vertical force down, towards the foundation system. The foundation system is then allowed to dissipate the base shear generated by the lateral loads.

## CONCLUSION

The existing conditions of Heifer International Center were explored in this report. The foundation system, gravity systems and lateral systems were each summarized. It was found that an extensive foundation system involving a Rammed Aggregate Pier<sup>®</sup> System by Geopier Foundation Company, Inc. was used in conjunction with a slab-on-grade, piers, footings and grade beam system. A Mat Foundation was designed for the large water tower on the front façade of the building.

The gravity system was explored in more detail, for the floor and framing systems. A composite deck, with steel beams and girders, was utilized to support floor loads that were in turn transferred to large HSS pipe columns. The roof used a slightly different system of timber and steel framing. An exhaustive understanding of how the structural floor and framing system work will be needed for future Technical Assignments and design assignments.

The lateral system employed a Steel Plate Shear Wall at several locations throughout the building. This was used to transfer wind and seismic loads, encountered by the floor and roof diaphragms, to the foundation system. This will represent a large challenge in future Technical Assignments because this lateral system has not been discussed in previous structural classes and makes up a large portion of Heifer International Center.

Common joint details were discussed as well as the design codes and standards referenced in the design and construction. Computer modeling performed in future assignments will have to be meticulously completed in order to properly model the Heifer International Center as two separate structures with an abutment and seismic joint.

Loadings were based on the ASCE-7 1998 Code, while concrete and steel designs were governed by ACI and AISC, respectively. As a redesign and analysis are instituted on the building, the new ASCE-7 2010, IBC 2012, and most recent ACI and AISC manuals will be referenced. The most recent codes, new analysis methods, and requirements will have to be explored.

Heifer International Center will offer a strong educational challenge, due to its odd geometry and intricate structural systems.