

# Jackson Crossing

Alexandria, Virginia



## Proposal

Michael Bologna  
Structural Option

---

December 11, 2015  
Advisor: Dr. Linda Hanagan

## Table of Contents

Executive Summary .....	3
Introduction	
Purpose .....	4
Scope .....	4
General Building Description .....	4
Structural System	
Structural System Overview .....	6
Gravity System .....	6
Lateral System.....	11
Materials .....	14
Building and Design Codes .....	15
Design Loads	
Gravity Dead Load.....	16
Gravity Live Load.....	17
Gravity Roof Live Load .....	18
Lateral Loads.....	18
Details .....	19
Problem Statement.....	21
Proposed Solution .....	22
Solution Method .....	22
Breadth Topics	
Construction Management Breadth .....	23
Mechanical Breadth.....	23
M.A.E. Requirements .....	23
Tasks and Tools .....	24
Schedule .....	25
Closing Remarks .....	26
Appendix .....	27

## Executive Summary

Jackson Crossing is a development in Alexandria, Virginia by AHC, Inc. Offering one, two, and three-bedroom apartments, it is targeted at low-income residents with families. The structure is five floors and 107,740 square feet. Included in the building is an underground parking garage. The project will be completed by December 2015 and will come to a total project cost of sixteen million dollars.

The gravity system consists of four floors of wood floors with wood trusses and bearing walls. The wood members sit on two floors of concrete, one of which is below grade. The slab on the second floor is a reinforced two-way slab while the ground floor is a reinforced one-way slab with concrete beams.

The lateral system for the top four floors include masonry shear walls and wood shear walls with OSB sheathing. The wood shear walls are anchored into the second floor slab while the masonry shear walls are integrated into reinforced concrete shear walls that extend down into the foundation.

For next semester, the proposed design alternative is a concrete system with two-way reinforced flat plate floors and intermediate concrete moment frames. In addition, the transfer beams on the ground floor will be reevaluated considering the additional load from the alternative concrete system. If the beam needs to be deepened, the clearance below the beam on the garage level will be checked.

The two-way flat plate slab will be analyzed with finite analysis using RAM Concept to meet the requirements of Chapter 13 in ACI 318-11. The forces in the intermediate concrete moment frames will be found by modeling the frames in ETABS. The design of the frames will meet the requirements of Section 21.3 in ACI 318-11.

Breadth topics that will be researched include the cost of the material and formwork required for the alternative system. In addition, the impact of a much thinner structural system on the mechanical ducts will be investigated to provide possible solutions.

Graduate level course work will be met by using knowledge gained from courses in the Integrated B.A.E./M.A.E. program. Techniques gained from AE 530, Computer Modeling of Building Structures, and AE 538, Earthquake Resistant Design of Buildings, will be used to model the lateral system and design the frame.

## Introduction

### **Purpose**

To prepare for a redesign of Jackson Crossing, this report will examine the existing structure and identify how it was designed to find an alternate structural system.

### **Scope**

The first section will cover the general information on Jackson Crossing. Then the existing structural system will be described in detail including the gravity frame, lateral system, and the material properties that are used in these systems.

### **General Building Description**

Jackson Crossing is a five story above grade residential apartment for low income residents in Alexandria, Virginia just south of Washington D.C. The location of Jackson Crossing in relation to Washington D.C. is depicted in Figure 1. The apartment is ideally located across the street from the Potomac Yards shopping center for easy access to commercial shops and retail. Jackson Crossing will feature a community space for education programming, onsite management, and an underground parking garage. Also, public transit is easily accessible to residents as bus service is nearby and metro for the area is currently being planned.



Figure 1 (Courtesy of Google Maps) – Location of Jackson Crossing in relation to Washington D.C.

AHC, Inc. is the owner and contacted Harkins Builders, Inc. to handle the construction. Construction began in April 2014 and is scheduled to finish in December 2015. The project cost of the building came to a total of 16 million dollars. The architect of the project was Bonstra-Haresign Architects and the structural engineer was Rathgeber/Goss Associates.

The typical floor plan of Jackson Crossing is an L shape with a long dimension of 256' 11 5/8" and a short dimension of 63' 3 5/8" as in Figure 3. The east side of the floor plan has a slightly longer dimension of 74' 4 5/8" to form the L. The main corridor is located in the middle of the floor plan with the residential units lined around the perimeter. Vertical circulation is provided by two elevator and stairwell cores at each end of the building as highlighted in green in both Figure 2 and Figure 3 (on next page).

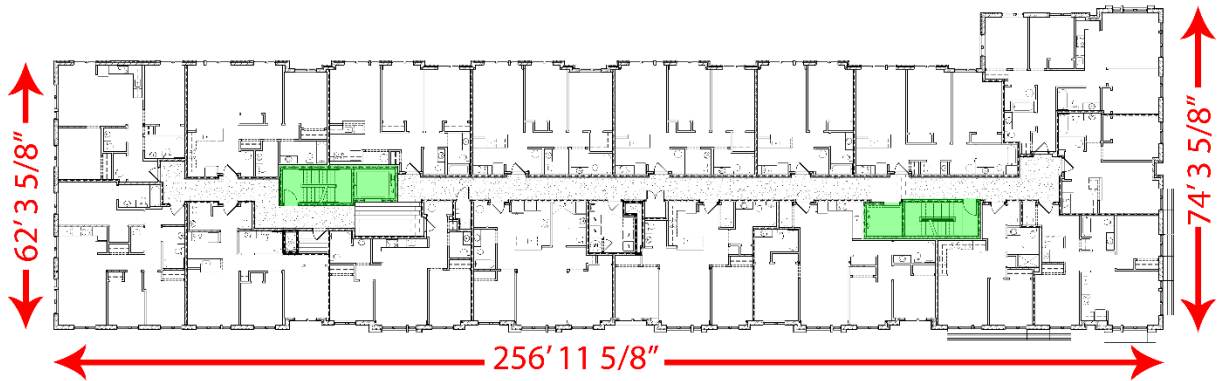

Figure 2 - Typical Floor Plan

The site of Jackson Crossing is on a slope that decreases in elevation from the east to the west as shown in Figure 3. The lower garage level starts below grade as in Figure 4 where a ramp elevates cars up to the next garage level. The residential levels begin at the first floor and up for the rest of the floors. The height of the building from the average grade to the top of the parapet is 55' 5".

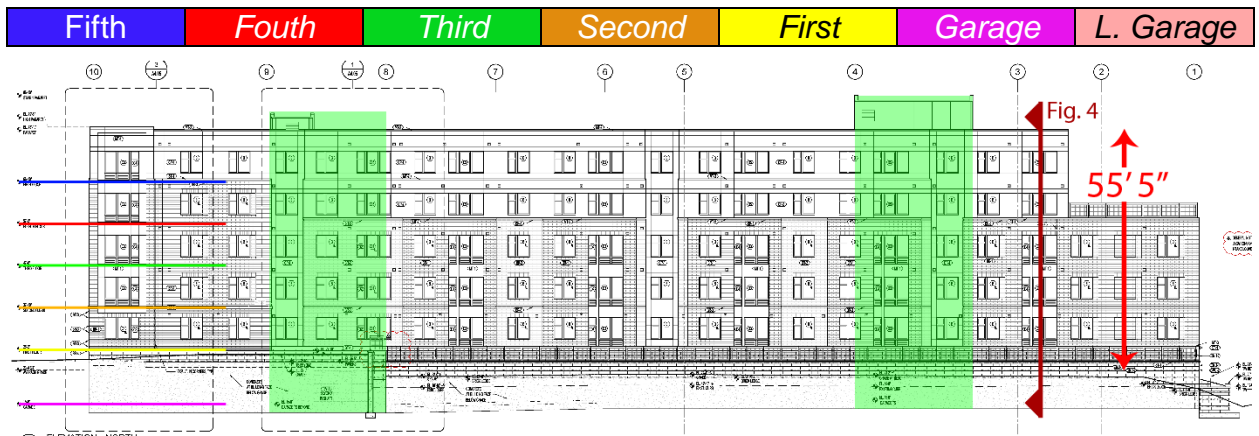

Figure 3 - North Elevation of Jackson Crossing

The building section in Figure 4 also shows the floor to floor height for the stories above the first floor. The typical residential floor has a floor to floor height of 9' 8".

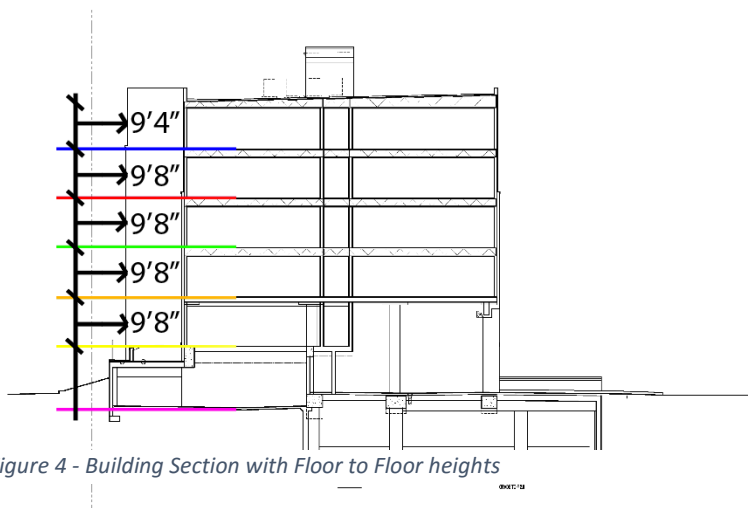

Figure 4 - Building Section with Floor to Floor heights

## Structural System

This section describes the structural system of Jackson Crossing including its gravity system and lateral system while providing an overview of the structure as a whole. The properties of the structural materials are also detailed.

### Structural System Overview

Rathgeber Goss Associates designed the structure of Jackson Crossing with concrete and wood members. Figure 4 depicts how the concrete and wood levels interact. From the second floor to the roof level the structure is a wood frame designed to handle residential units. The bearing walls, part of the wood frame, extend down to the second floor where they rest on a concrete slab.

The slab at the second floor is a two-way reinforced concrete slab while on the first floor there is a one-way reinforced slab. The parking garage levels are slabs on grade where concrete columns come down to a pile cap. These pile caps are generally two feet below the elevation of the slab on grade. The foundation system uses 12" diameter auger cast piles.

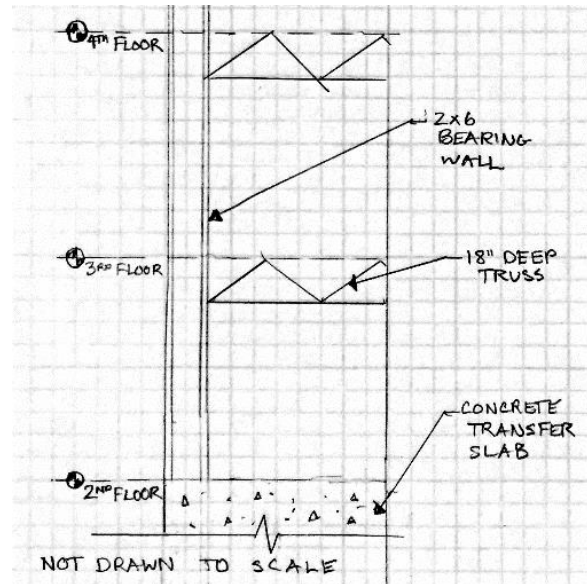

Figure 5 – Structural System Interaction

### Gravity System

#### Roof Level Framing

The framing at the roof level of Jackson Crossing consists of engineered wood trusses and wood bearing walls. In Figure 7 (on next page) the wood trusses are highlighted in blue while the wood bearing walls are outlined in green. The wood trusses are spaced at a maximum of 24" on center and are sloped on the top chord with a maximum depth of 29". The wood bearing walls typically have 2x6 studs spaced at 16" on center. The trusses are attached to the bearing wall with two rows of 12d nails spaced at 3" on center as shown in Figure 6.

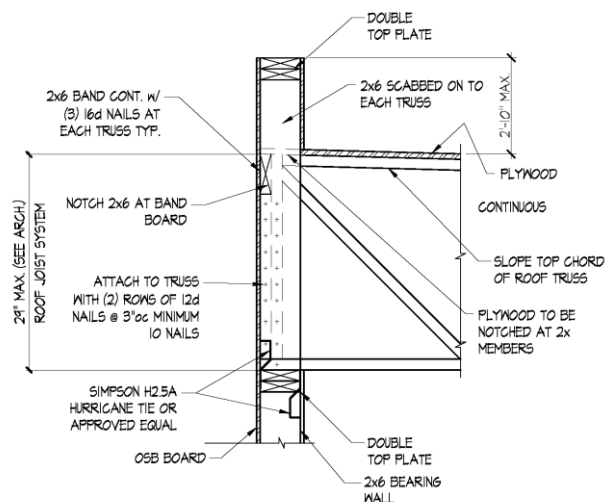

Figure 6 – Wood Truss to Bearing Wall Connection at Roof



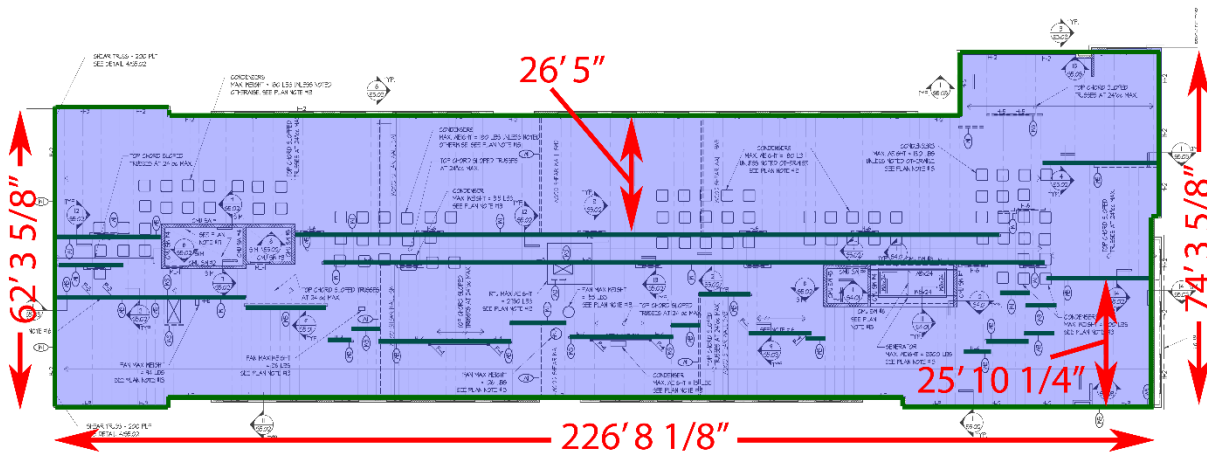

Figure 7 - Roof Level Framing ( BLUE: Wood Trusses | GREEN: Wood Bearing Walls )

### Fifth Level Framing

The framing at the fifth level is generally identical to the roof level as shown in Figure 7. The difference on the fifth level is that the wood trusses are 18" deep at a maximum of 24" on center. The wood bearing walls are still 2x6 wood studs spaced at 16" on center. The typical connection between the wood truss and bearing wall at the fifth level is shown in Figure 8. The wood trusses are connected to a 2x6 continuous band beam with three 16d nails at each truss.

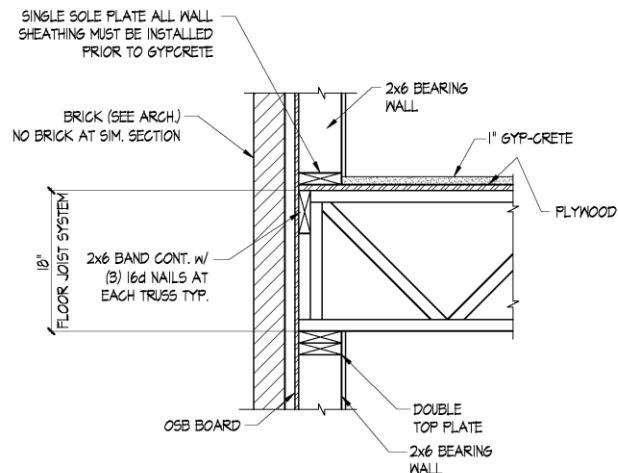

Figure 8 – Wood Truss to Bearing Wall Connection at Fifth Floor

### Fourth Level Framing

The framing at the fourth level is also wood trusses and bearing walls. The truss spacing is affected by a roof terrace located at this level. In Figure 9 (on the next page) the area shaded in yellow represents the wood trusses supporting the roof terrace. These wood trusses are 14" deep and are spaced at a maximum of 16" on center. The increased spacing is to account for the heavier weight of the roof terrace compared to the typical floor. The area shaded in blue in Figure 9 represents wood trusses that are 18" deep and spaced at a maximum of 24" on center. In addition the orange lines are locations of wood truss girders to allow for openings in the bearing walls. These wood bearing walls are outlined in green in Figure 9 and typically have 2x6 studs spaced at 16" on center. The connection between the wood truss and wood bearing wall are similar to the connection in Figure 8.

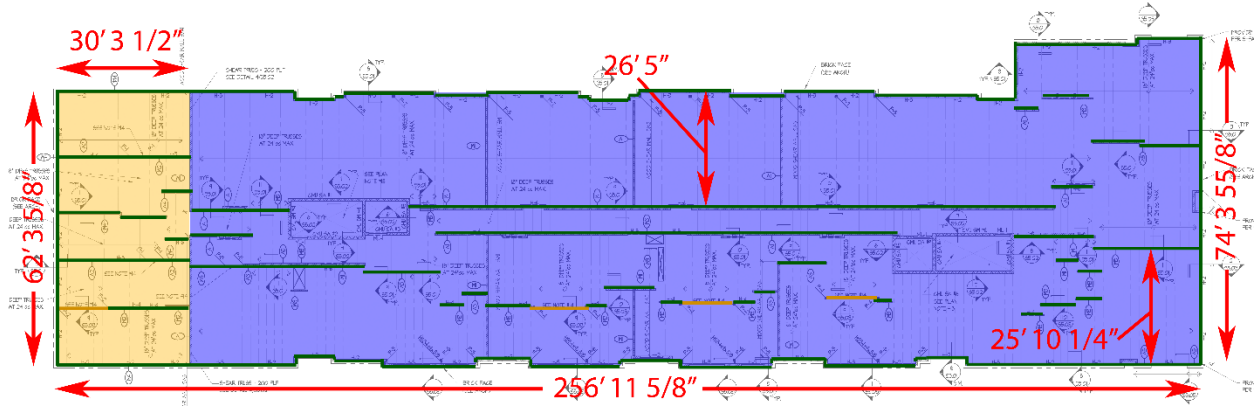

Figure 9 - Fourth Level Framing ( BLUE&YELLOW: Wood Trusses | GREEN: Wood Bearing Walls | ORANGE: Wood Truss Girders )

### Third Level Framing

Figure 10 is a floor plan of the third level framing. Similar to the fourth floor, 18" deep wood trusses are spaced at a maximum of 24" on center while wood truss girders are outlined in orange. For vertical distribution of forces, wood bearing walls outlined in green continue below the third level and typically have 2x6 studs spaced at 16" on center.

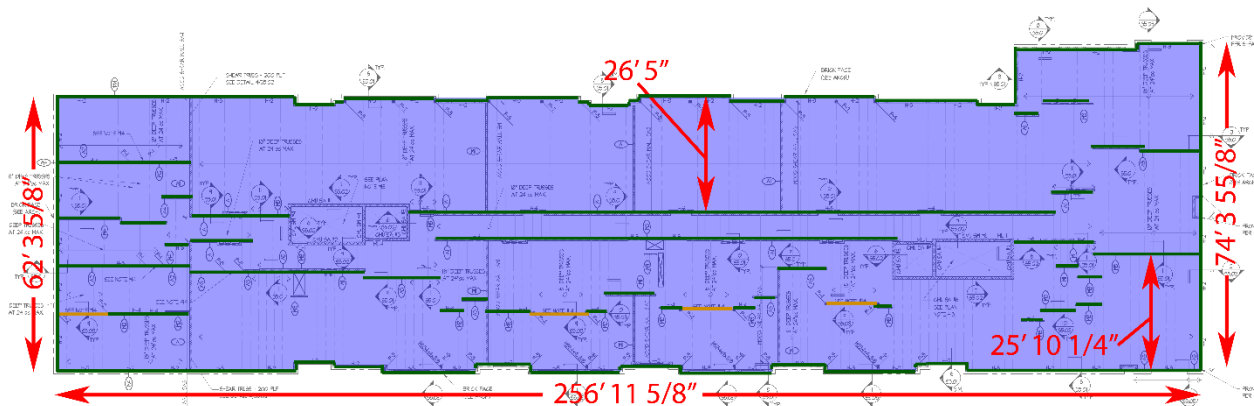

Figure 10 - Third Level Framing ( BLUE: Wood Trusses | GREEN: Wood Bearing Walls | ORANGE: Wood Truss Girders )



**Second Level Framing**

The structural floor system at the second level is a two-way reinforced concrete slab. The slab is 12" deep and has a bottom mat of #5 bars at 12" on center each way. The slab is support with concrete columns at locations shown with yellow icons in Figure 11. The columns are typically 16" by 24" and have a shear cap. In addition, the slab transfers loads from the wood bearing walls above the second level. The bearing walls are outlined in green in Figure 11.

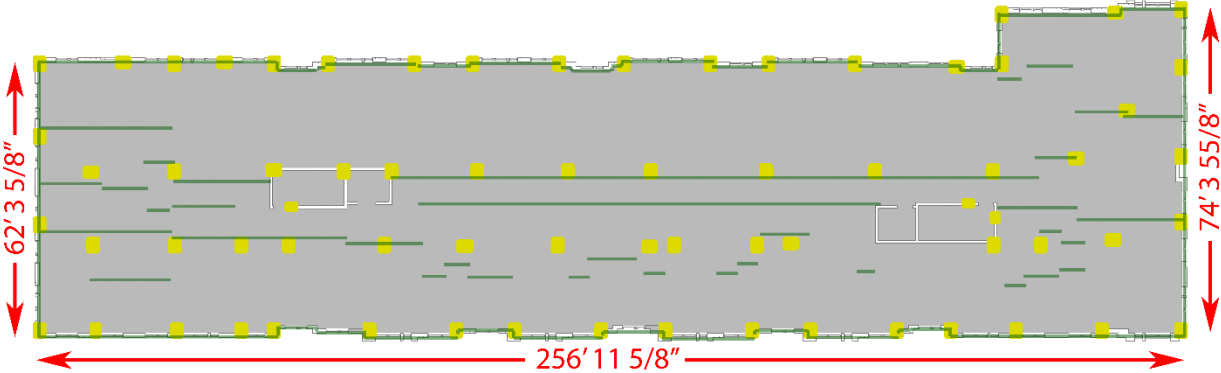

Figure 11 – Floor Plan of Second Level

**First Level Framing**

The first level is a 12" one-way reinforced concrete slab. The slab is reinforced with a bottom mat of #5 bars at 12" on center each way. It is supported by columns at locations shown in green and purple in Figure 12. The green columns support just the first level while the purple columns support both the first and second level. The yellow columns are transfer columns that are supported by the first level slab and concrete beams that are outlined in blue in Figure 12.

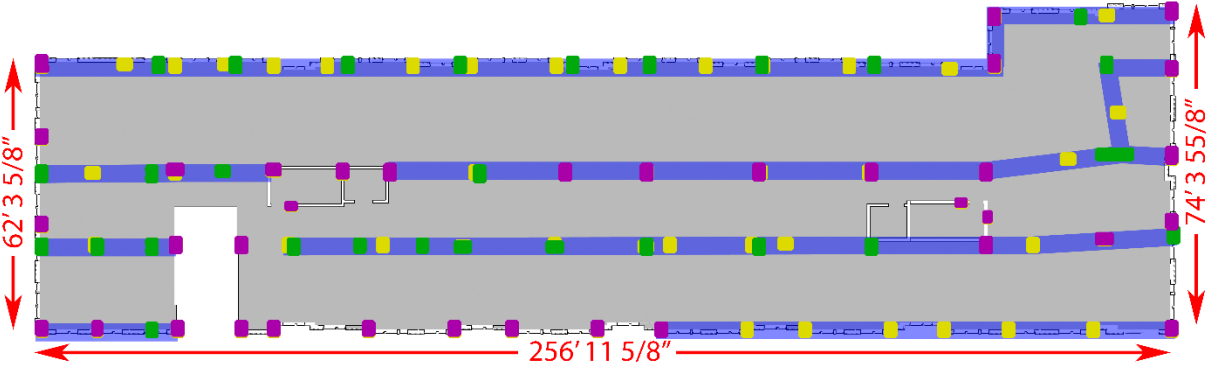

Figure 12 – Floor Plan of First Level

## Foundation Levels

The foundations of Jackson Crossing are located at the garage and lower garage level. The floor plan of the garage level is shown in Figure 14 while the lower garage level is shown in Figure 15. In both Figures 14 and 15 the shaded grey area represents a 5" slab on grade that is reinforced with 6x6 – W2.9xW2.9 welded wire fabric and is over a vapor barrier with a 6" gravel base. Grade beams are outlined in orange.

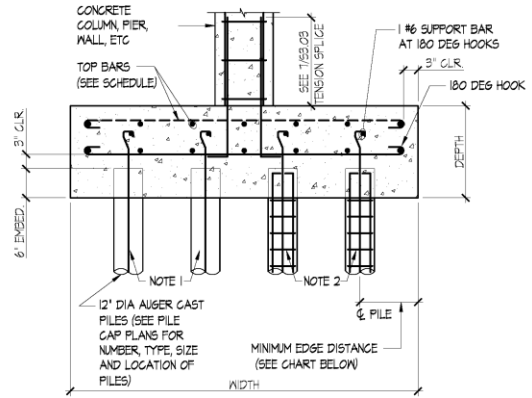

Figure 13 – Auger Cast Pile Detail

The green and blue icons in Figures 14 and 15 represent the locations of pile caps and auger cast piles supporting columns above them. The green icons are 12" diameter auger cast piles with a #8 center bar. The blue icons are similar 12" diameter auger cast piles but in addition to a #8 center bar they have #3 rebar cages. The connection of center bars into the pile cap is shown in Figure 13. The piles are developed into the pile cap by a #6 support bar with a 180 degree hook.

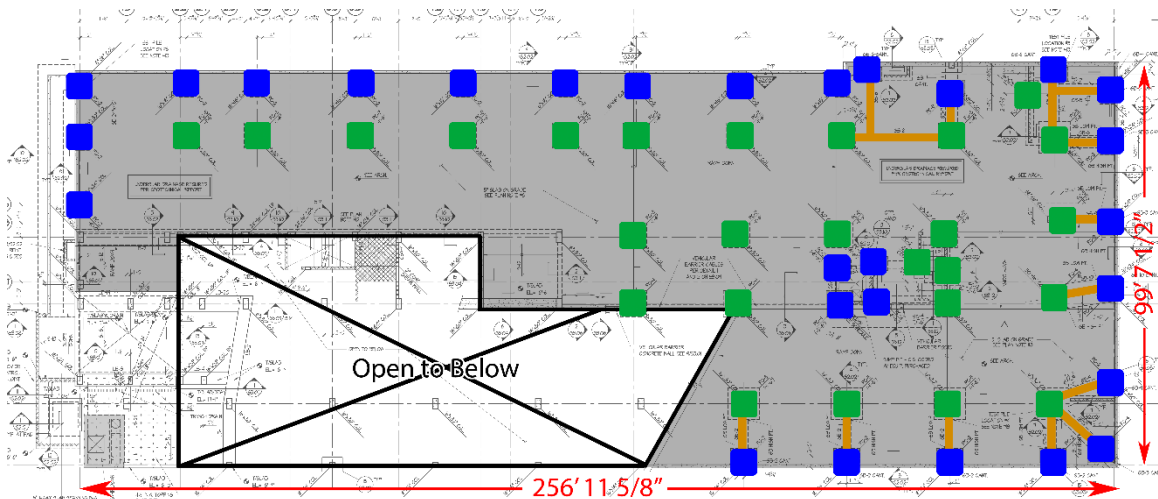

Figure 14– Foundation Plan of Garage Level

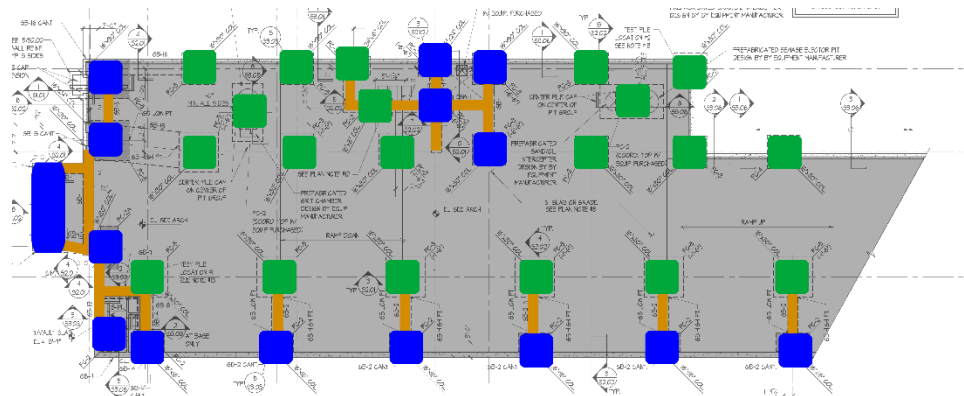

Figure 15 – Foundation Plan of Lower Garage Level

## Lateral System

Figure 16 is an overview of the lateral system in Jackson Crossing. From the foundations of Jackson Crossing to the second floor, the lateral system in both plan directions is concrete shear walls. Above the second floor, the lateral system transitions to masonry shear walls and wood shear walls.

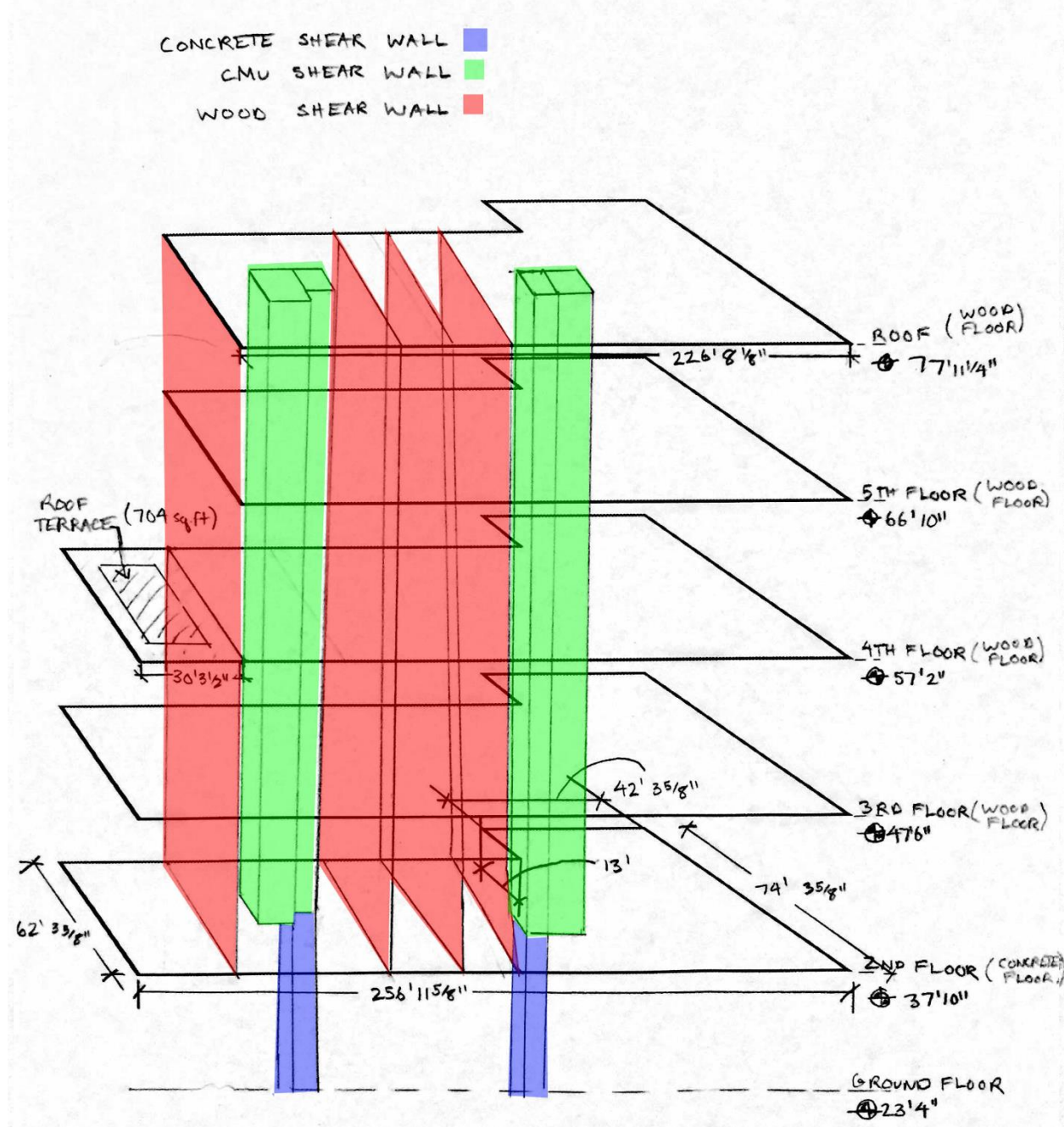

Figure 16 – Overview Diagram of the Lateral Systems

**Concrete Shear Walls**

The locations of the concrete shear walls on a ground floor plan are highlighted in blue in Figure 17. The concrete shear wall core on the left rest on grade beams and pile caps at the lower garage level as shown in Figure 15 while the shear wall core on the right rest on pile caps at the garage level as shown in Figure 14.

The shear walls are typically 8” thick with #4 bars at 12” on center for both longitudinal and latitudinal reinforcement with additional reinforcement around openings. In addition, the shear walls are developed into the pile caps with #4 dowels.

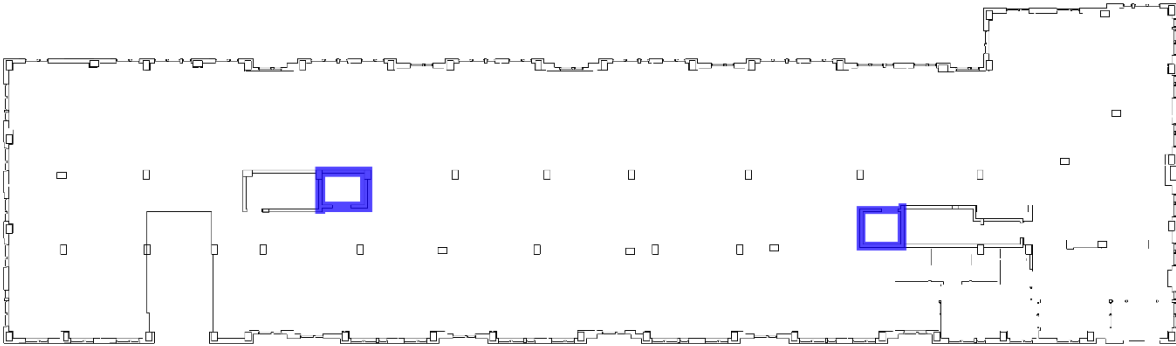

Figure 17 - Location of Concrete Shear Walls at Ground Floor

**CMU Shear Walls**

The CMU shear walls are highlighted in green for a typical floor plan in Figure 19 (on next page). The CMU walls that rest on the concrete shear walls at the second floor are connected to the concrete with dowels as shown in Figure 18.

The CMU are 8” solid grouted blocks typically reinforced with #6 bars at 16” on center or #5 bars at 24” on center.

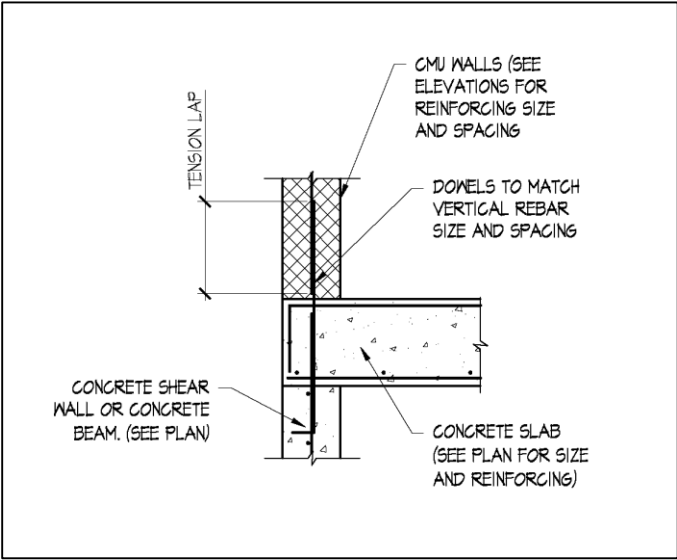

Figure 18 – CMU Shear Wall to Concrete Shear Wall Connection

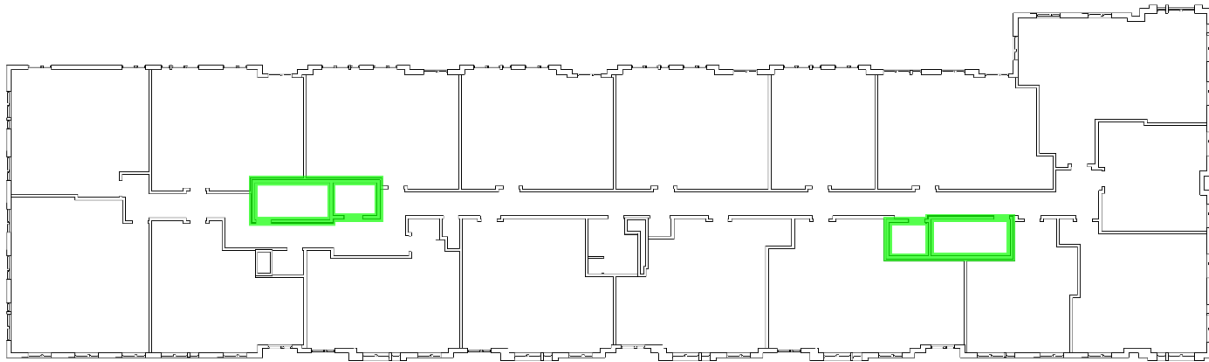

Figure 19 - Location of CMU Shear Walls on Typical Floor Plan

### Wood Shear Walls

The location of the wood shear walls on a typical floor plan are highlighted in red in Figure 20. The walls are anchored into the two way slab on the second floor with a bottom plate with  $\frac{1}{2}$ " diameter HILTI HAS rods at 4' on center. These rods are embedded into the slab 4".

The shear walls are typically sheathed with  $\frac{7}{16}$ " OSB wood structural panel sheathing on one side. The panels are connected with 8d common nails and are blocked on all panel edges.

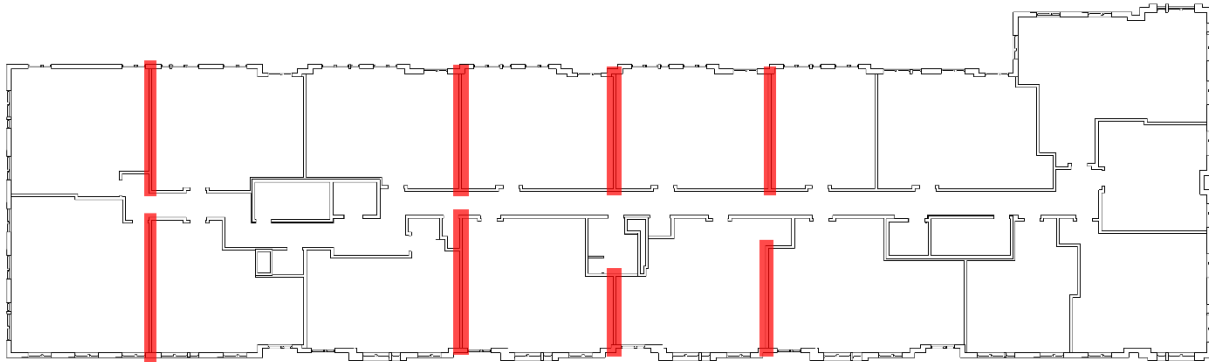

Figure 20 – Location of Wood Shear Walls on Typical Floor Plan

**Materials**

All of the sawn lumber structural members for Jackson Crossing are specified as spruce-pine-fir or hem fir with a maximum moisture content of 19%. The properties of the wood load bearing walls are listed in Table 1. The properties of the concrete specified for use in Jackson Crossing are listed in Table 2.

<b>Fb</b>	875 psi
<b>Fc (PAR)</b>	1150 psi
<b>Fc (PERP)</b>	425 psi
<b>Fv</b>	135 psi
<b>E</b>	1,400,000 psi

**Table 1 – Properties of Load Bearing Walls**

<b>Application</b>	<b>f'c @ 28 days (psi)</b>	<b>Weight (PCF)</b>	<b>W/C (Max)</b>
<b>Slabs-on-Grade (Interior)</b>	3000	145	0.50
<b>Slabs-on-Grade (Exterior)</b>	4500	145	0.45
<b>Reinforced Slabs</b>	5000	145	0.45
<b>Reinforced Beams</b>	5000	145	0.45
<b>Columns</b>	4000	145	0.50
<b>Walls</b>	4000	145	0.50
<b>Grade Beams</b>	3000	145	0.55
<b>Pile Caps</b>	3000	145	0.55
<b>Footings</b>	3000	145	0.55
<b>Parking Structure Concrete, Excluding Slabs-on-Grade</b>	5000	145	0.40
<b>Interior Topping Slab</b>	4500	115	0.45
<b>Exterior Topping Slab</b>	4500	145	0.45

**Table 2 – Properties of Concrete**



## Building and Design Codes

The general building codes and standards used for Jackson Crossing were IBC-2009, ASNI/ASCE 7-02-2005, and VIRGINIA UNIFORM STATEWIDE BUILDING CODE-2009. Additional codes are listed in Table 3.

Code Category	Applicable Code
<b>Concrete</b>	“Building Code Requirements For Reinforced Concrete, ACI 318”, American Concrete Institute “Specifications For Structural Concrete, ACI 301” “Manual of Standard Practice”, Concrete Reinforcing Steel Institute
<b>Masonry</b>	“Building Code Requirements For Masonry Structures, ACI 530/ASCE 5” And “Specifications For masonry Structures, ACI 530.1/ASCE 6”
<b>Wood</b>	“National Design Specification For Wood Construction” (With Supplement), National Forest And Paper Association “Performance Standard And Policies For Structural Use Panels”, PRP-108, American Plywood Association (APA) “American National Standard For Wood Products – Structural Glued Laminated Timber”, ANSI/AITC A190.1-A992, American Institute of Timber Construction
<b>Steel</b>	“Steel Construction Manual”, Latest Edition, American Institute of Steel Construction (Including Specifications For Structural Steel Buildings, Specification For Structural Joints Using ASTM A325 or A490 Bolts, And AISC Code of Standard Practice With Exception, If Any, As Indicated In the Specifications “Detailing for Steel Construction”, American Institute of Steel “Structural Welding Code ANSI/AWS D1.1”, American Welding Society
<b>Other Applicable Codes</b>	2009 Virginia Construction Code 2009 Virginia Plumbing Code 2009 Virginia Mechanical Code 2009 Virginia Energy Conservation Code 2008 National Electric Code (NFPA 70) 2003 ICC/ANSI A117.1

**Table 3 – General Building Codes and Standards**

## **Design Loads**

This section focuses on identifying what loads need to be considered for design and they will be determined for use in future analyses. These loads include both gravity and live loads.

### ***Gravity Dead Load***

Values for dead loads will be determined from the following references:

- Steel Construction Manual, 14<sup>th</sup> Edition
- Design of Wood Structures, 7<sup>th</sup> Edition

The following sections in this report discuss the different materials in the floor and wall system of Jackson Crossing that contribute to the dead load.

### ***Roof System***

The dead load for the roof system consists of the weight of the following material:

- Single Ply Roof Membrane
- 2" Rigid Insulation
- 23/32" Subfloor
- 9 1/2" Thermafiber Batt Sound Insulation
- 5/8" GWB
- Engineered Wood Truss

### ***Typical Wood Floor System***

The dead load for the typical wood floor system consists of the weight of the following material:

- 1" Gypcrete
- 1/4" Floor Mat
- 29/32" Subfloor
- 5/8" GWB
- 3 1/2" Batt Sound Insulation
- Floor Finish
- Mechanical Equipment
- Engineered Wood Truss

*Typical Concrete Floor System*

The dead load for the typical concrete floor system consists of the weight of the following material:

- Floor Finish
- 3 1/2" Batt Sound Insulation
- 5/8" GWB
- Concrete Slab
- Mechanical Equipment

*Typical Exterior Brick Wall*

The dead load for the typical exterior brick wall consists of the weight of the following material:

- 4" Face Brick
- 1/2" Plywood
- 1 1/4" Continuous Insulation
- 5/8" GWB
- 2x6 Stud
- 5 1/2" Cellulose Insulation

*Typical Exterior Cementitious Wall*

The dead load for the typical exterior cementitious wall consists of the weight of the following material:

- 5 1/2" Cellulose Insulation
- 1 1/4" Continuous Insulation
- 1/2" Plywood
- 2x6 Studs
- 5/8" GWB
- 1/2" Cementitious Panel

**Gravity Live Load**

The Live Loads from the IBC-2009 are listed in Table 6. Live Load Reduction will be used when applicable per code.

Area	Load
Living Units	40 PSF
Lobbies/Stairs/Exits	100 PSF
Corridors Above 1 <sup>st</sup> Floor	40 PSF
Parking Decks	40 PSF
Roof Terrace	100 PSF

**Table 4 – IBC-2009 Live Loads**

### ***Gravity Roof Live Loads***

The ground snow load for Jackson Crossing will be determined from Figure 1608.2 in the IBC-2009. Flat roof snow loads will be determined from section 7.3 of ASCE 7-05 while snow drifts will be determined from section 7.7 of ASCE 7-05.

### ***Lateral Loads***

Table 5 lists the sections from ASCE 7-05 that will be used to determine lateral loads for the lateral force resisting system of Jackson Crossing

<b>Lateral Force</b>	<b>Procedure</b>	<b>Source</b>
<b>Wind Load</b>	Analytical	Section 6.5 of ASCE 7-05
<b>Earthquake</b>	Equivalent Lateral Force	Section 12.8 of ASCE 7-05

**Table 5 – Determination of Lateral Loads**



**Typical Bearing at Exterior Trusses Parallel to Wall**

At an exterior wall for a floor level, 1" Gyp-Crete sits on plywood over the floor joist system. 2x4 flat braces are set at 4 feet o.c. and nailed to each bottom chord with two 10d nails. Also, 2x4 Kickers brace the joists and are connected with two 10d nail as Figure 10 depicts.

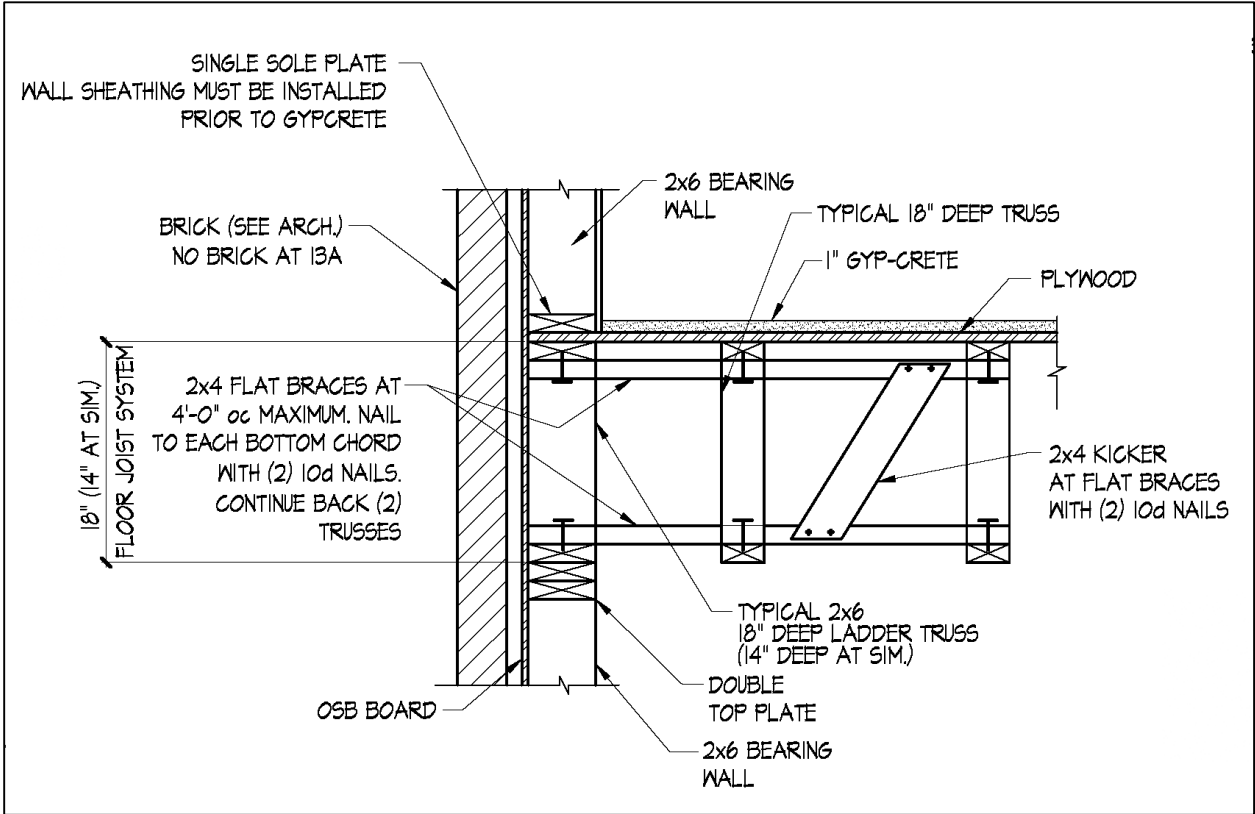

Figure 22



# Problem Statement

As previously mentioned the current structural design of Jackson Crossing uses a concrete base supporting a wood truss and bearing wall system. This system was found to be more than sufficient for the design loads determined through Submission A to Submission C.

For a design alternative, a complete concrete system will be investigated for both the gravity and lateral system. While the existing structural system of Jackson Crossing is a light and low cost solution, a concrete structure is worth considering as it is durable and provides a thin floor system. The design alternative will not increase the overall height of the building and will keep the same typical floor to floor height unless the alternative floor system decreases the floor to ceiling height.

One problem with the design alternative is how the added weight of a complete concrete system compared to the existing wood frame system will impact the transfer beams at the ground floor level. One of these critical beams is highlighted in red in Figure 23. In this figure the column transferring loads from the five floors above it is marked with a green circle and an arrow pointing to its location. The existing specifications of the highlighted transfer beam are 48” by 36” with 14 #10 bottom bars and 8 #9 top bars. The loads on this transfer beam from the alternative design will be analyzed to determine the impact of the revised dimensions on the garage level clearance below the beam.

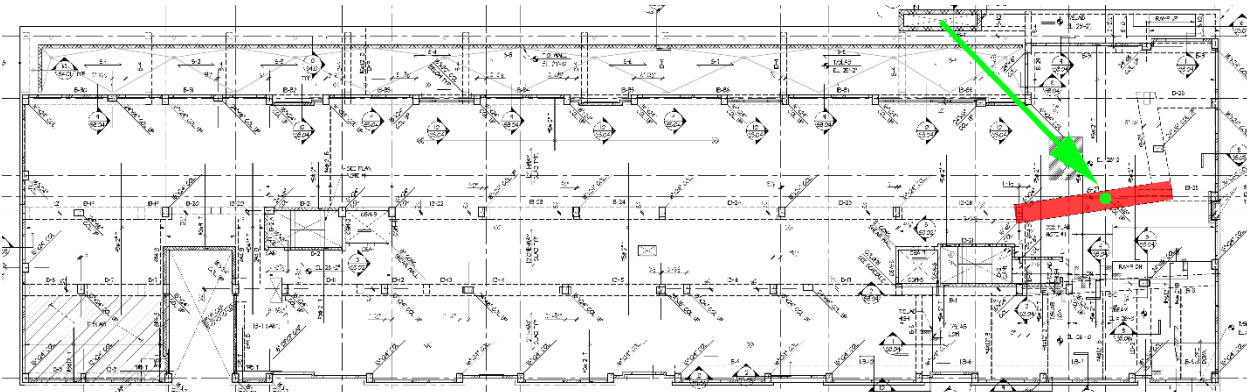

Figure 23 - Location of Critical Transfer Beam at Ground Floor

## Proposed Solution

The gravity system for the design alternative will be a reinforced two-way concrete flat plate system. The initial slab thickness will initially be based on the minimum thickness needed without considering deflection found in ACI Table 9.5 (c). Based on this table and a maximum span of 24' 6", the initial slab thickness will be considered to be 9". Further reductions in slab thickness will be investigated using deflection limits in ACI Table 9.5 (b). The dead load on the floor slab will include the self-weight of the slab in addition to other building systems supported by the structure. The live load will come from the required values previously listed in Table 4 from the IBC 2009.

To minimize impact on the floor plan, the layout of the columns supporting the flat plate slabs will match with the existing column layout of the ground floor shown in Figure 23. In this figure the columns are marked in red. Because the columns will continue from the ground floor, the second floor will not be a transfer slab as with the previous structural system.

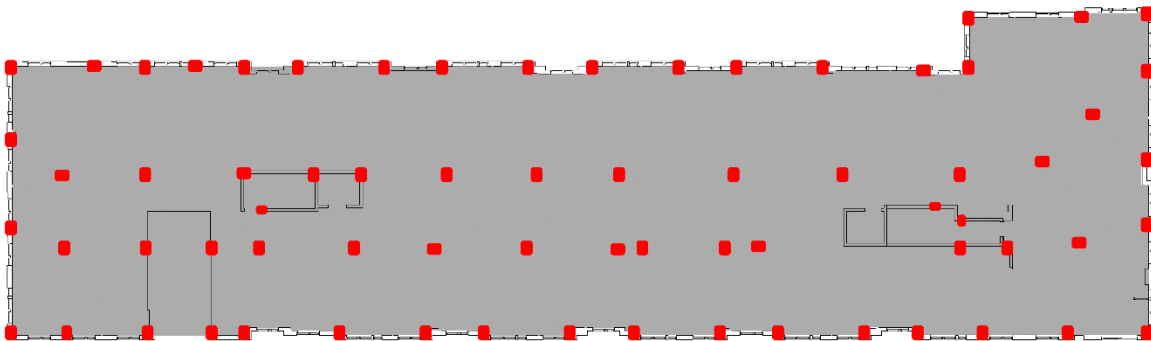

Figure 24 - Existing Column Layout of Ground Floor

The lateral system for the design alternative will integrate intermediate concrete moment frames into the two way flat plate system. By utilizing the moment frames, the CMU walls around the elevator and stairwell cores will not be part of the lateral force resisting system as is the case in the existing structural system. The earthquake loads will be evaluated again considering the alternative lateral system and ASCE 7-10.

## Solution Method

The reinforced two-way flat plate will be designed in RAM Concept using finite analysis and will meet the requirements for a two-way system in Chapter 13 of ACI 318-11. The intermediate concrete moment frames will be modelled in ETABS to find the forces on the frame from lateral loads. The design of the moment frames will meet the requirements specified in Section 21.3 of ACI 318-11.

## **Breadth Topics**

### ***Construction Management Breadth***

The focus of the construction breadth will be the difference in cost associated with a concrete system compared to the existing structural system that contributed to an overall project cost of \$16 million dollars. The analysis will consider the cost required for the formwork and material to pour the two-way reinforced flat plates and columns. In addition the cost of labor associated with the alternative design system will be studied.

### ***Mechanical Breadth***

The existing structural floor system in Jackson Crossing is 18" deep trusses. The mechanical ducts run through these trusses and are hidden by 5/8" ceiling drywall. The mechanical breadth will explore how the alternative structural system will interact with the mechanical ducts considering the depth of the flat plates will be much thinner than the trusses. This includes how the ducts will be supported below the two-way flat plates and how the ducts will be hidden from the view of the occupants.

## **M.A.E. Requirements**

To incorporate graduate level coursework, the alternative design will include skills and concepts learned from classes in the Integrated B.A.E./M.A.E. program. The modeling of the lateral system will require knowledge in lateral frame design acquired from AE 530, Computer Modeling of Building Structures. The design of intermediate reinforced concrete moment frames will use lessons learned in AE 538, Earthquake Resistant Design of Buildings.

## Tasks and Tools

- I. Reinforced Two-Way Flat Slab Alternative
  - a. Gravity System
    - i. Slab Design
      1. Determine IBC 2009 required live loads for each floor
      2. Model floor slabs in RAM Concept
      3. Iterate slab thickness based on ACI Table 9.5 (b)
      4. Finalize reinforcement
    - ii. Column Design
      1. Determine loads in columns at base level
      2. Design reinforcement
    - iii. Check transfer beams on ground floor
  - b. Lateral System
    - i. Determine ASCE 7-10 Wind and Earthquake Loads
    - ii. Model moment frames in ETABS
    - iii. Output frame forces from ETABS
    - iv. Design dimensions and reinforcement of columns and beams
- II. Breadths
  - a. Construction Management Breadth
  - b. Mechanical Breadth
- III. Final Report
  - a. Organize information to be included in final report
  - b. Draft final report
  - c. Revise final report
  - d. Adapt final report into presentation
  - e. Rehearse final presentation
  - f. Submit final report and present to the jury

# Proposed Thesis Semester Schedule

January 2016 - April 2016

Michael Bologna | Structures  
Faculty Advisor | Dr. Linda Hanagan

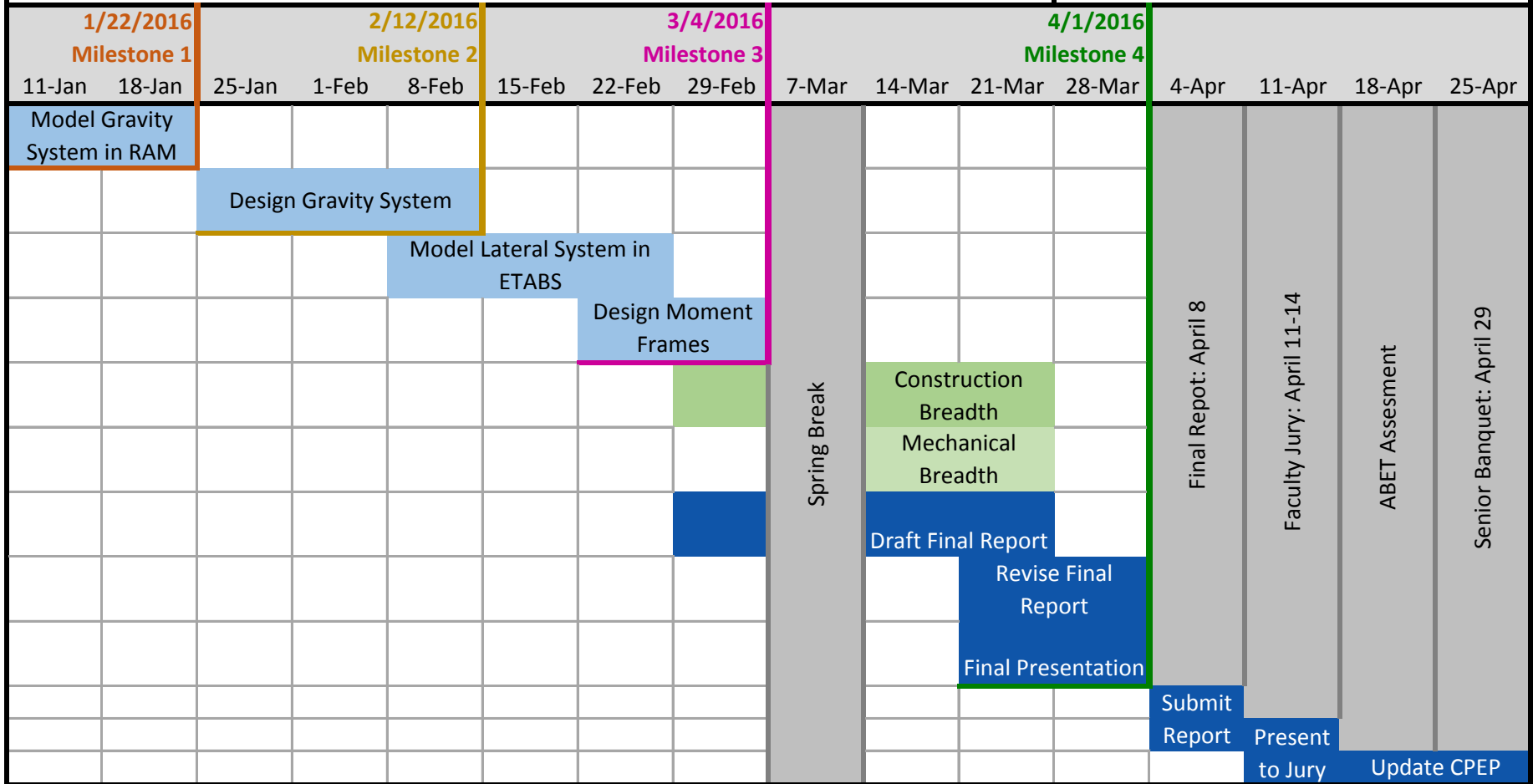

### Milestones

- 1 Complete RAM Concept Model
- 2 Finalize Gravity System
- 3 Finalize Lateral System
- 4 Complete Breadths and Final Report

### Key

- Structural Depth
- Construction Breadth
- Submission Tasks

## **Closing Remarks**

The alternative design of Jackson Crossing will explore designing the structure in concrete versus the existing concrete and wood frame system. The alternative concrete system will be designed with reinforced two-way flat plates for the gravity system and intermediate concrete moment frames for the lateral system. The breadth topics will cover the costs associated with the alternative system and the interaction with the mechanical ducts in the floor system. Graduate level requirements will be met with knowledge obtained from AE 530, Computer Modeling of Building Structures, and AE 538, Earthquake Resistant Design. The lessons from these classes will aid in the modeling and design of the lateral system.

While the current structural system of Jackson Crossing is effective, an alternative system is still worth evaluating especially in an academic setting.



# Appendix

## Elevations

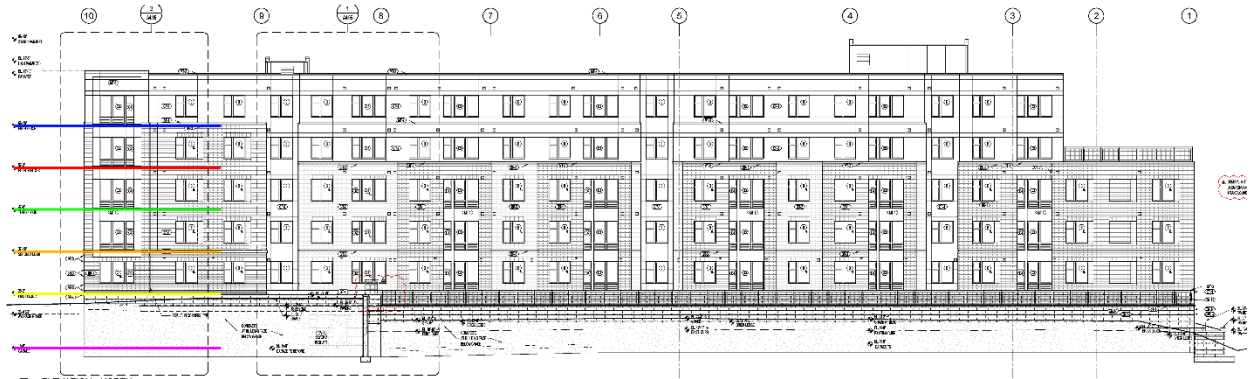

Figure 25 – North Elevation

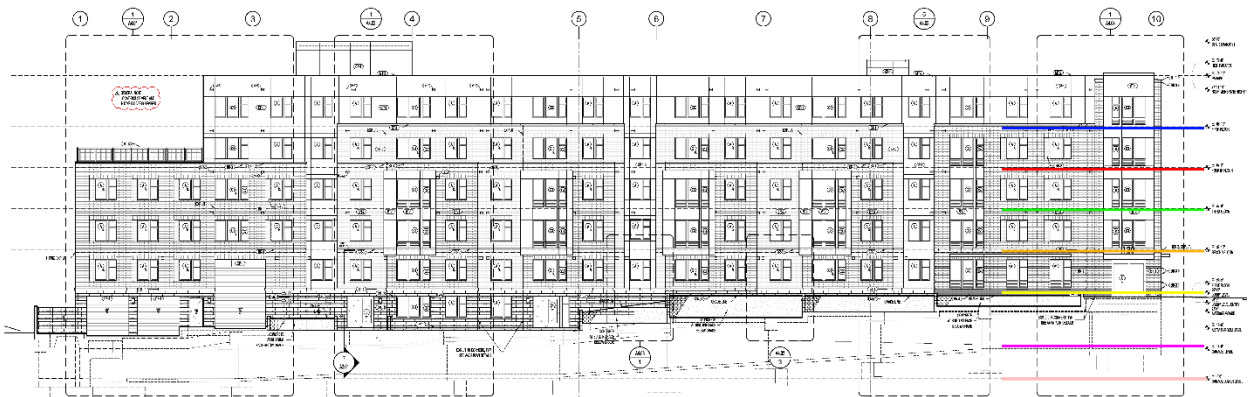

Figure 26 - South Elevation

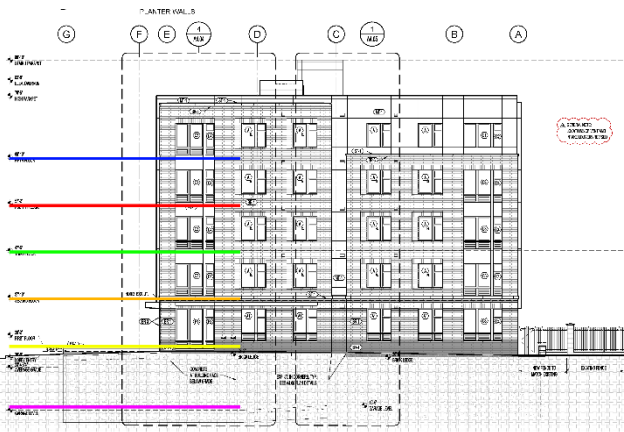

Figure 27 – East Elevation

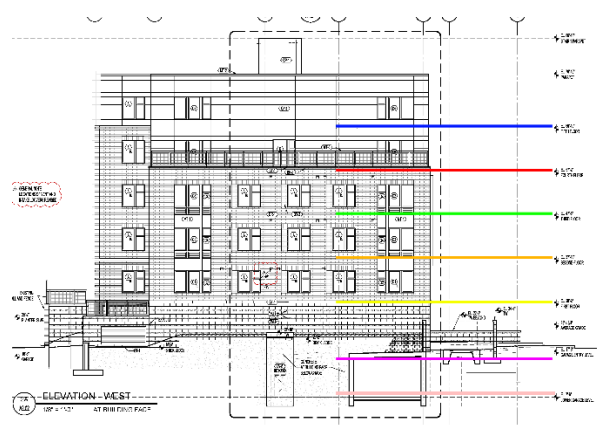

Figure 28 – West Elevation

# Floor Plans

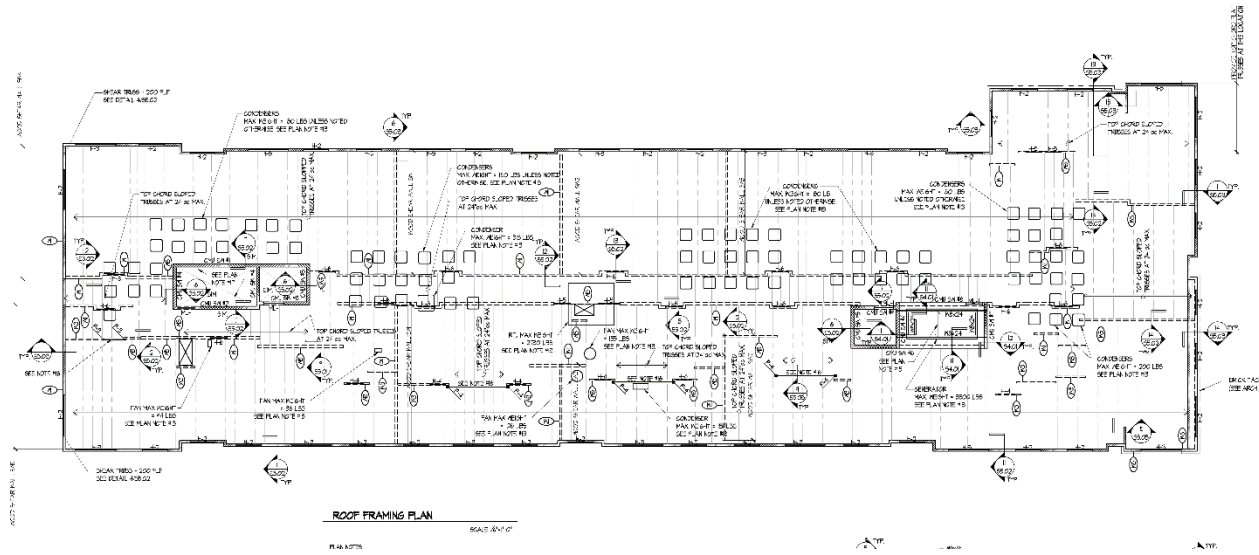

Figure 29 - Roof Framing Plan

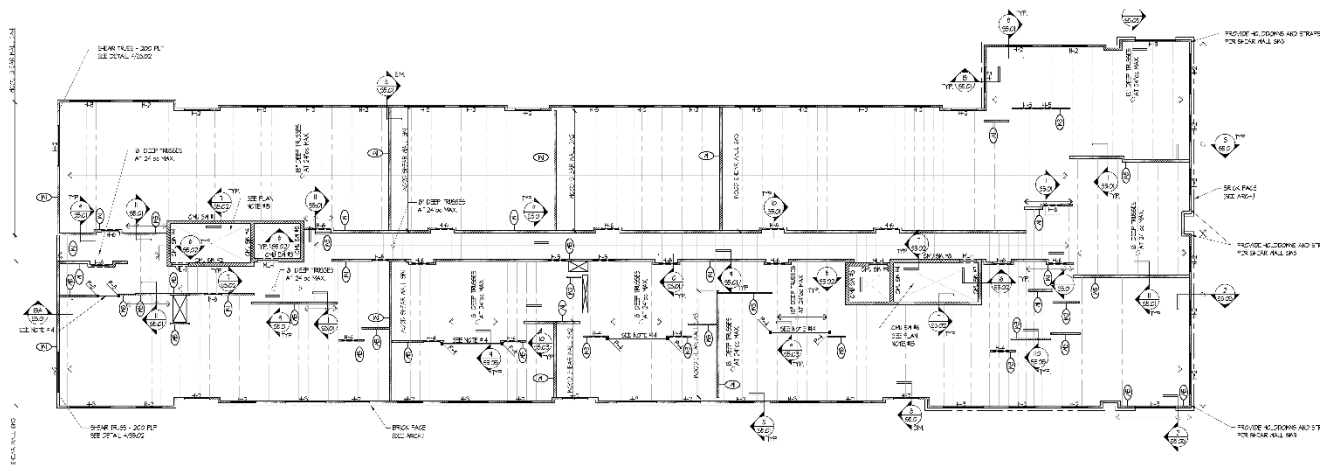

Figure 30 - Fifth Floor Plan

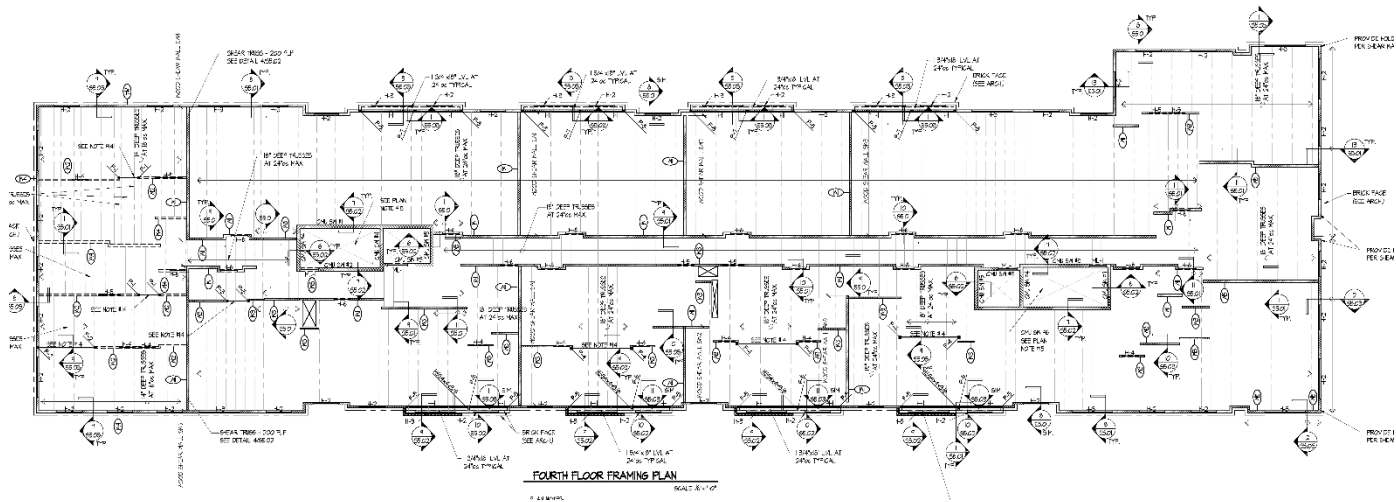

Figure 31 - Fourth Floor Plan

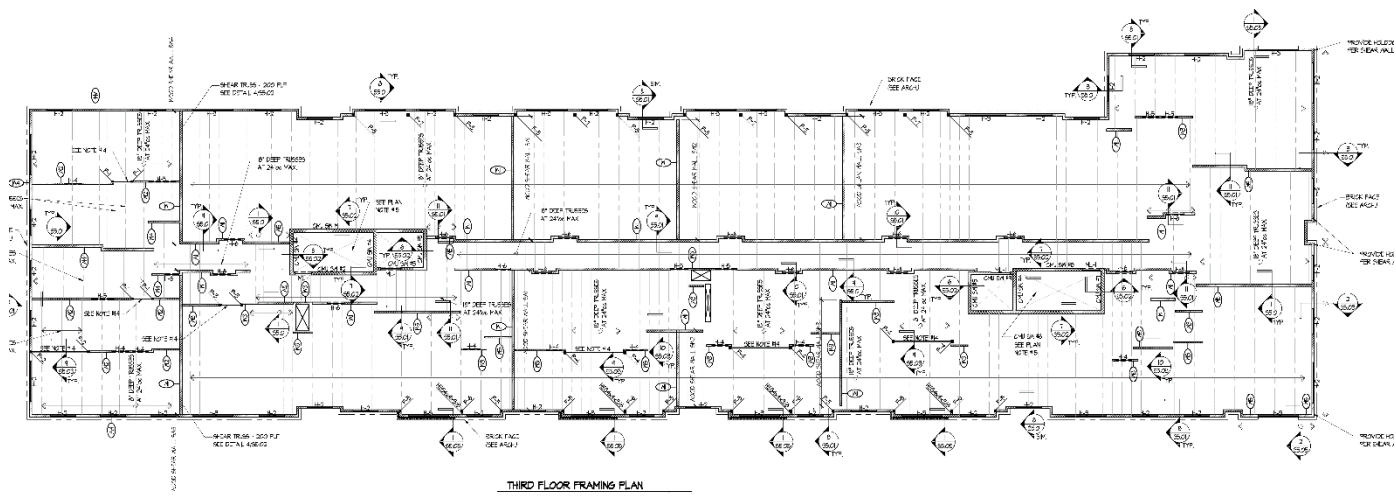

Figure 32 - Third Floor Plan

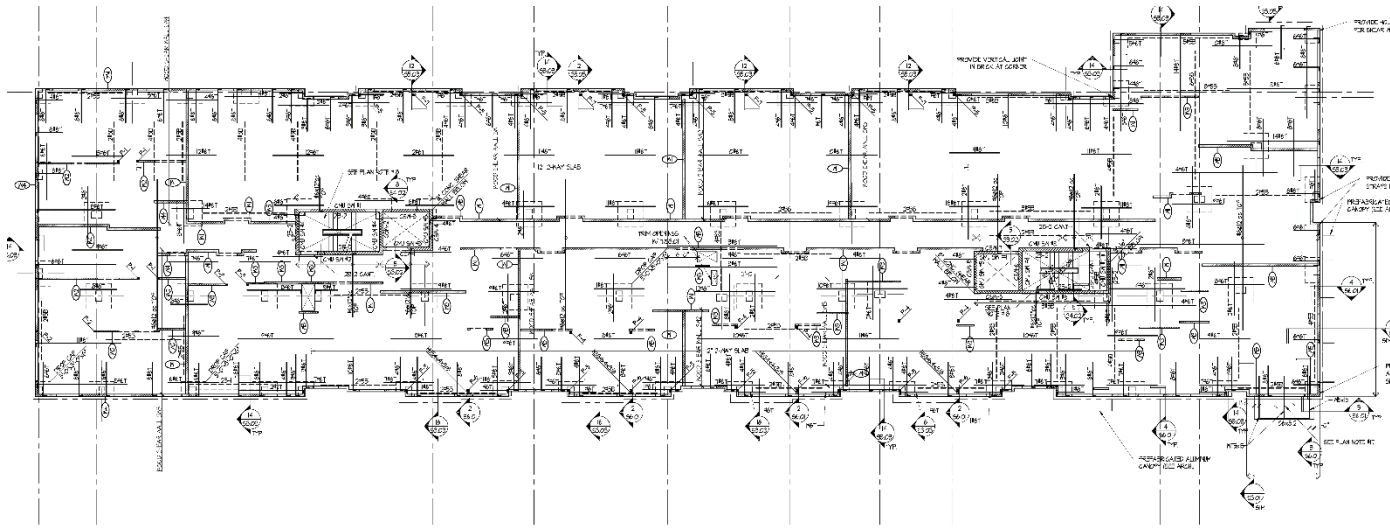

Figure 33 - Second Floor Plan

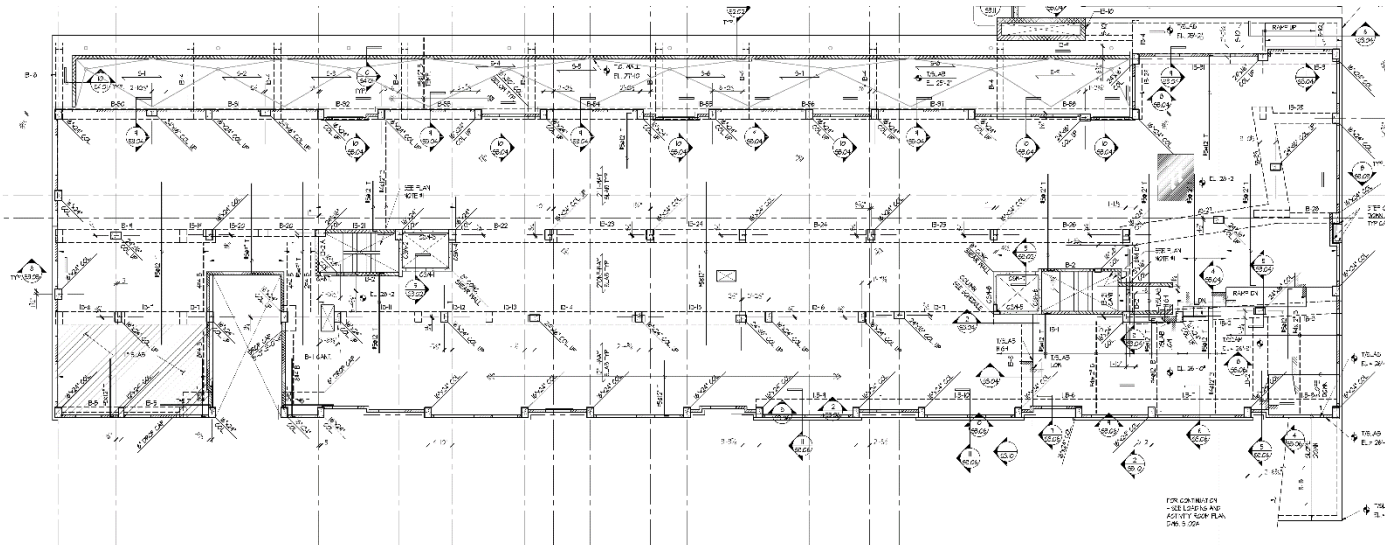

Figure 34- First Floor Plan

