

The Pennsylvania State University
Architectural Engineering Senior Thesis

**PENTAGON RENOVATION
WEDGE 3**

Arlington, VA



Julie Rankin
Construction Management

Advisor Dr. David Riley



Pentagon-Wedge 3 Renovation



Jefferson Davis Highway
Arlington, VA

GENERAL PROJECT INFORMATION

- **Type:** Demolition and Renovation
- **Building Purpose:** Office space / US department of defense operations
- **Estimated cost:** \$367 million
- **Contract:** Design Build, fast track
- **Start Date:** June, 2005
- **Finish Date:** February 2, 2007
- **LEED accredited:** Silver Rating

PRIMARY PROJECT TEAM

- **Owner:** PenRen—Pentagon Renovation
- **General Contractor:** Hensel Phelps Construction Co.
- **Architect:** Shalom Baranes Associates
- **Mechanical and Plumbing:** Southland Industries
- **Electrical:** M.C. Dean
- **Demolition:** LVI
- **Carpentry:** P&P Contractors
- **Masonry:** Masonry ARTs

ARCHITECTURE

- Unique five sided geometry with five concentric rings
- Approximately 1 million square feet—Wedge 3
- Five stories above grade, 77 feet tall
- Each side 921 feet long
- Universal Space Plan—open environment

STRUCTURAL SYSTEM

- Existing Building built in 1941
- CIP Concrete Columns
- CIP Concrete girders and beams—span 20' to 40'
- One-way Concrete Slabs—5" to 10" thickness
- Columns doubled at expansion joints

LIGHTING / ELECTRICAL

- Highly efficient fluorescent lighting
- High CCT—natural light look
- Utilizes daylight for 15% energy savings
- Telecommunication closets disperse local data and communication wiring in 4" conduit and overhead cable trays

MECHANICAL

- Air is conditioned off site from Wedge 3
- Overhead round duct delivery / no return ducts
- Induction units

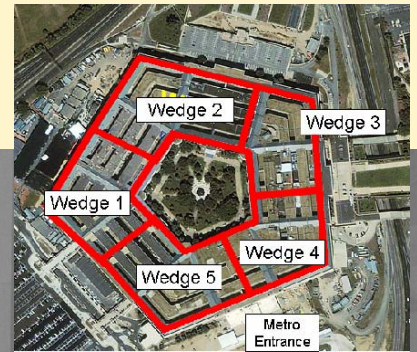

Julie Rankin
Construction Management

<http://www.arche.psu.edu/thesis/eportfolio/current/portfolios/jlr380/>



Executive Summary

This report summarizes a year's worth of research of the Pentagon Renovation Wedge 3. The *project background* section provides details about the buildings history, architecture and the current construction project. *Pentagon 101* is a brief tutorial to orient a stranger with the layout of Wedge 3.

The three analyses that were performed involved construction management and other breadth research topics.

A green roof system was designed to place on the roof of the Pentagon, including a structural breadth with loading calculations. It also explores the extensive type of roofing required and the growth mediums ideal for the climate in Arlington, VA. This requires durable plants that withstand drought, saturation and both hot and cold temperature.

A second topic evaluates placing a raised access floor in a large portion of the office and control room spaces. In addition, a mechanical breadth explores the existing air circulation patterns and suggest an improvement by placing the return and supply air in different locations.

A third evaluation looks at the demolition plan and proposes an alternative way to remove debris during the summer demolition process.

Brief Table of Contents

Project Background.....	ii
Pentagon 101.....	iii
Green Roof.....	1
Structural Breadth	
Access Floor.....	2
Mechanical Breadth	
Demolition Plan.....	3
Project Teams Research.....	4
Acknowledgements	



Project Background

Building History	ii.2
Client Information	ii.3
<i>Cost</i>	ii.4
<i>Quality</i>	ii.4
<i>Schedule</i>	ii.5
<i>Safety</i>	ii.6
<i>Occupancy</i>	ii.6
Project Delivery System	ii.7

Pentagon Renovation Wedge 3



Arlington, VA

Building History

The well-known Pentagon structure owes much of its appearance to the political and social climate during the time of its construction. It was built during World War II, and in an effort to not exhaust the supply of metals needed for war machines, the structure was designed as fully cast in place poured concrete. The only structural steel originally found in the Pentagon was reinforcement in the concrete. Now in the renovated area, there are steel reinforcing beams to support penetrations cut for utility risers and people moving systems.

The Pentagon Reservation is a massive plot of land along the Potomac River near the Arlington Cemetery, directly across from Washington. The reservation is an astounding 296 government owned and usable acres, of which 29 acres are consumed by the actual structure, and with 67 acres of parking space. With such a vast area, there was ample space for lay down area, and on site parking. For Wedge 3, the existing Pentagon employee parking lot in front of wedge 3 and the mall terrace entrance has been closed and is off limits for their parking to serve construction trailers and lay down. Many of the daily construction employees and craftsmen park at the Pentagon's south parking lot across a pedestrian walkway, or at off site parking garages.





The land where the Pentagon was built was originally a swampy marshland on the banks of the Potomac River. Though drained, it is susceptible to soggy ground conditions. The foundation of the original concrete structure has settled, and the ground below it has compressed, unevenly at times, over the years under the immense weight of the building, but the structure is still sound.

As this building renovation project strives for LEED certification, it naturally involves recycling in the construction process. Old materials are sorted and recycled after their demolition, and new materials for the rebuilding are recycled as well. The Pentagon reservation also is located near an alternative fuel station with higher efficiency fuel, which helps to, giving another credit to the building for LEED certification.

Client Information

The owner of the project is a government program known as the Pentagon Renovation Program, commonly referred to as PenRen. Wedge 3 is only one part of a large renovation plan to rebuild the entire reservation, including not only the immediate structure, but also a new metro entrance, and a remote deliveries facility. PenRen was formed out of necessity to have a team of people leading the renovation project.



This construction project is crucial because the building is now nearly sixty four years old, and many of its' major systems have yet to be updated. Tenants have repeatedly enclosed areas for personal office space, reducing efficiency for flow of the old air supply. Old pipes suffer from leaks, rust and corrosion. Asbestos materials were common in construction in the 1940's, and over 23 million pounds of asbestos material are found throughout the Pentagon, including floor and ceiling tiles and various insulation. PCB's were visible in the ballasts of lighting systems and lead paints still coat much of the space. In total, the building's systems were outdated, inefficient, hazardous, and ironically often times failing building codes. In recognition of this,

Pentagon Renovation Wedge 3



Arlington, VA

PenRen initially developed guidelines and standards, for quality, cost and safety.

One of the prominent goals of PenRen was to achieve an economical, aesthetic, and most importantly uniform new look for the Pentagon. Another expectation was that the updates would last for at least fifty years before another major renovation was necessary, prompting them to set the specifications in construction contracts for a fifty year design.

Cost

The major cost concern that PenRen had during the developmental stages of Wedges 2 through 5 was keeping the project on the predetermined budget. Wedge 3 is comprised mostly of office space, with repetitive systems and floor plans. Therefore, if a part of the design specified equipment or material that was less cost efficient than an alternative, the price is multiplied throughout the entire floor plan, making the costs for inefficiency substantial. To avoid this, the architect, general contractor and PenRen worked closely through the design process, creating mock ups in an attempt to alleviate issues during construction.

Quality

PenRen has established extremely high expectations for a quality product. To ensure that work is performed to the fifty year specification plan, the owner has implemented their own quality control team. This quality control team works closely with the general contractor's quality control team. They have developed a method of four phases



of quality control. Daily inspections are a large part of this plan. Some of these inspections include the Initial, In-house, Pre-final, and Final. All items are listed and tracked through a system called Prolog, which ensures that punch list items are not overlooked.

Pentagon Renovation Wedge 3



Arlington, VA

A system of tagging is used during inspections. The tags are color coded, so that various subcontractors recognize the tags hanging from objects and identify the color as their own to know if they are involved in addressing the issue. The color coding works as follows:

- Blue – Drywall / Carpentry
- Red – Mechanical
- Green – Electrical
- Orange – Caulk
- Purple – Other / Miscellaneous

All tagged items are entered into prolog by the QC administrators and tracked daily by PenRen and Hensel Phelps inspectors.

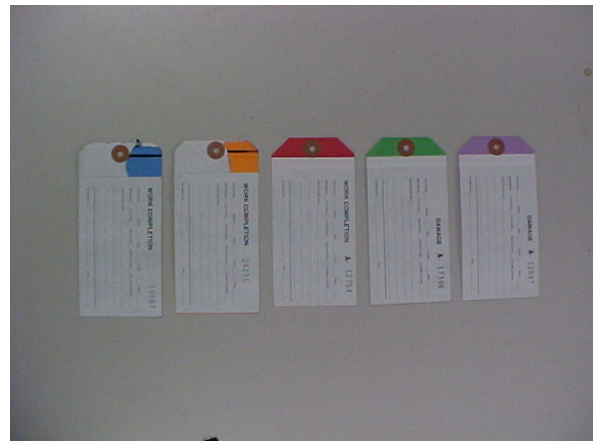

Schedule

When dealing with a renovation project of such magnitude, schedule is inherently a critical issue. Wedge 3 is only one wedge of five at the Pentagon, and with each one having a size of approximately one million square feet, it was important to the owner that each wedge was completed quickly, or else the space would be losing a lot of potential office space, and hence efficiency of its operations.

Initially, the entire Pentagon Master Plan Renovation was projected to be complete in 2014, with the finishing of the fifth wedge. This placed Wedge 3 at a completion date of 2009 or 2010. However, combining some unique acceleration ideas and SIPS, or short interval production schedules, the general contractor was able to develop a fast track schedule that calls for completion of the fifth wedge by 2010, setting Wedge 3 for full completion in 2007. This is one of the reasons that PenRen chose Hensel Phelps as the major general contractor for Wedges 2 through 5. The first phase of Wedge 3 will turn over to the owner in January of 2007, while the second phase will be turned over in October of the same year.



Safety

The owner, in conjunction with the general contractors, has set an extremely high standard for safety on the construction site. A major concern is keeping civilians and military personnel away from construction. The solution is to fully isolate all construction areas. Only individuals with a proper construction badge may enter the site at any time, and under no circumstances may escorted visitors enter. Properly trained Pentagon Police officers patrol the site daily to enforce this regulation.

Another example of the safety standard is the barrier wall. A metal framed, fire rated wall must separate usable Pentagon space from the construction zone. All penetrations must be caulked and fireproofed, leaving no gaps. Metal doors are installed for fire escape purposes, but they have plentiful signage discouraging any non-construction traffic.

It is necessary for anyone who is given a construction badge to undergo a safety training seminar, lead by a safety expert from the general contractor, Hensel Phelps. The class is offered in both English and Spanish, and is an approximately four hour session reviewing

A final example of the safety precautions is the enforcement of PPE, or personal protective equipment. Any individual entering the site must wear three articles of PPE, which are hardhat, a brightly colored construction vest, and safety glasses. The hardhat must face forward, and the safety glasses must not be darkly shaded or worn over glasses unless they are the proper design for that purpose.

Occupancy

Over 23,000 people work at the Pentagon everyday, some military and others civilians and civil servants. While this is not considered anywhere near the full capacity of the building, it is still a major concern of the owner that daily operations not be disturbed or productivity decreased as a result of the construction. Though tenants must be relocated during renovation, PenRen desires that the tenants are



accommodated. Tenants are notified months ahead of time as to the date that they will need to move their offices.

It is also important to the owner that each division of the military operating inside the Pentagon has the opportunity to be involved in the design phase of their new area. Involvement in the tenant fit out process ensures that the office spaces are comfortable and have efficiencies not possible in the section not yet renovated.

Project Delivery System

The Pentagon Wedge 3 is a contract that is separate from all other wedges' contracts. It is a design build project, with a fast track delivery. This was initially used for Wedge 2 construction and was successful, and will most likely be implemented throughout the remainder of the Pentagon Renovation.

The owner, PenRen, has a lump sum contract with the main general contractor, Hensel Phelps, who in turn has lump sum contracts with each of its' subcontractors. It is written into the contract between PenRen and Hensel Phelps that if the work is not completed on time and to the expected specifications, the general contractor must cover the cost. Also, the general contractor is reviewed on a quarterly basis and is eligible for bonuses depending on how their work is being performed.

The following organizational chart makes visible the contractual bonds between the owner, the general contractor and architect, and the subcontractors involved.

Pentagon Renovation Wedge 3



Arlington, VA

Project Delivery System – Primary Contractors

*Design Build
Fast Track*

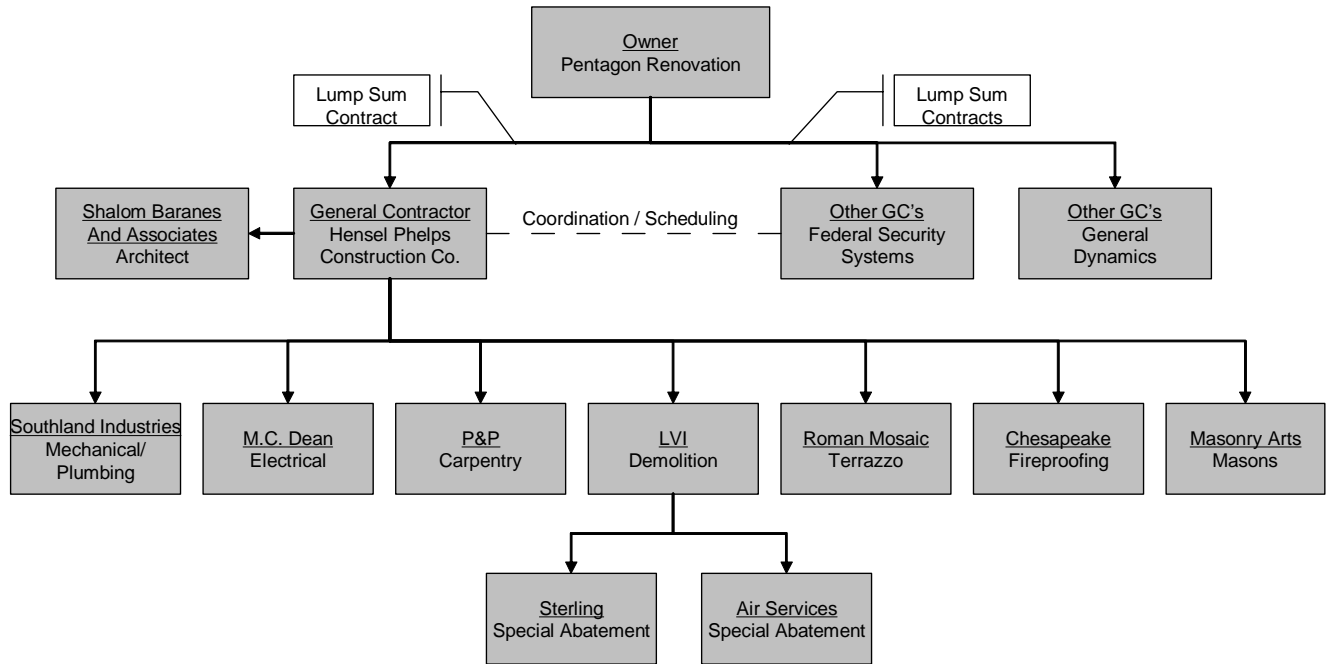



Pentagon 101

This section was added to rid some of the confusion about the Pentagon. Through this report, various regions will be referred to and this tutorial will help one understand the areas being discussed.

The Pentagon is organized into ten bays, and for the purpose of construction was divided into five wedges. Since September the 11th, a common question is, "Where exactly did the plane contact the building?" This occurred in what is called Wedge 1, and is shown below.

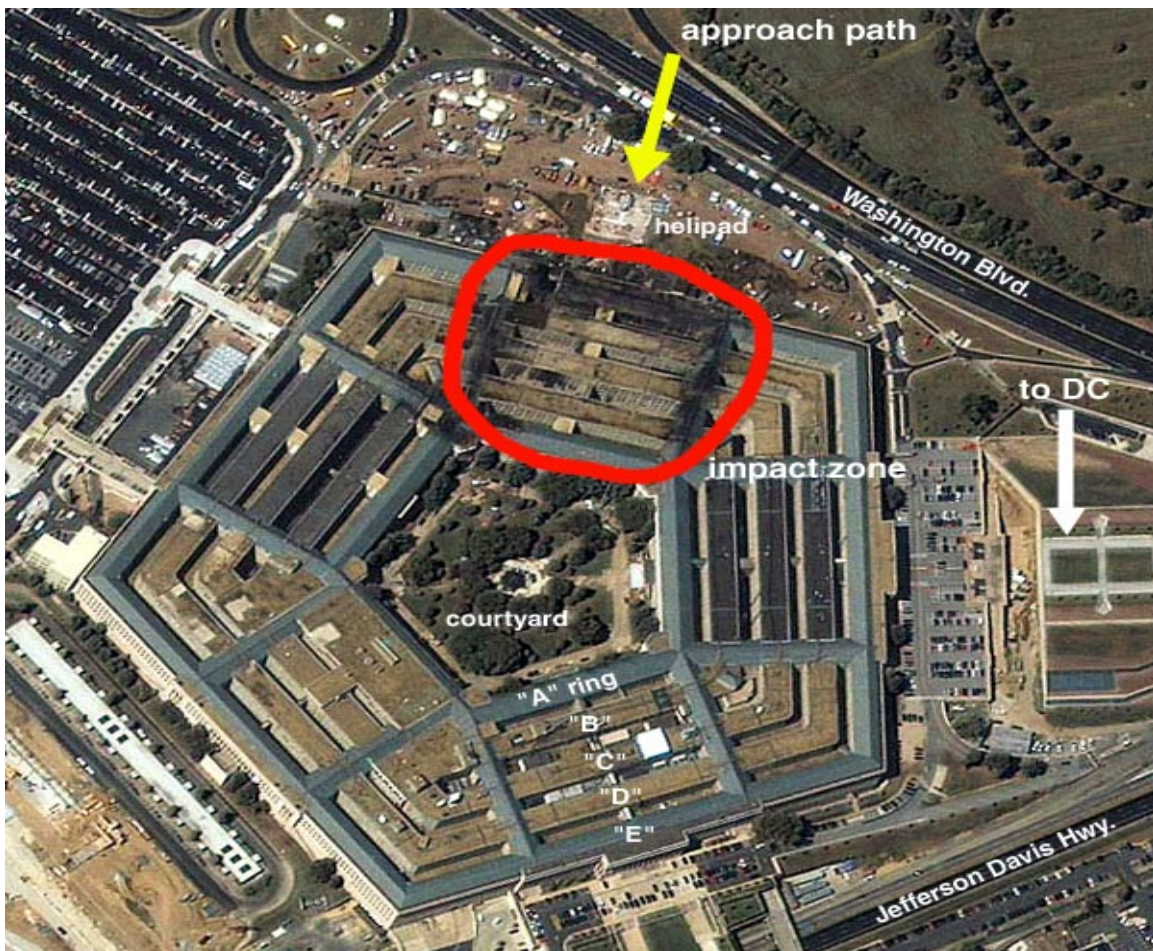

Pentagon Renovation Wedge 3



Arlington, VA

At the center of the complex is a five acres courtyard. There are five concentric rings, meaning each ring is inside another which radiate from here. The first ring in the center is called "A-Ring", then "B-Ring", etc., ending with "E-Ring" which is the outer most. Adding to the magic number five, there exist also five stories above ground.

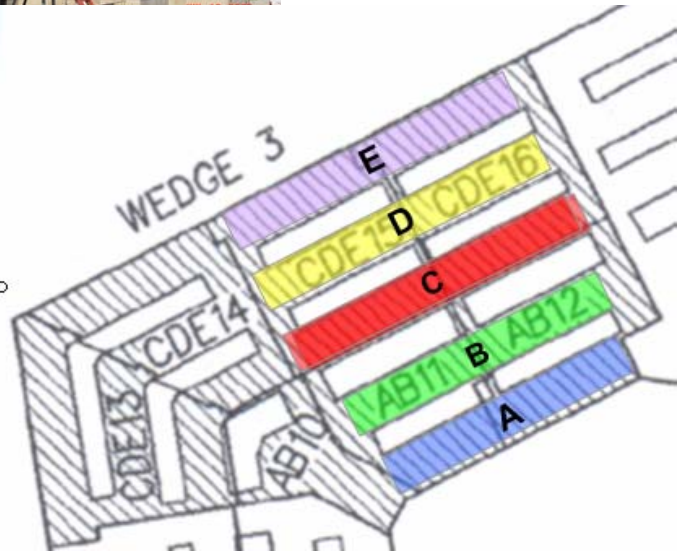

Wedge 3 is shown below on an aerial photo.



Pentagon Renovation Wedge 3



Arlington, VA

The construction plan separates Wedge 3, into two phases, shown below. The construction scope of Wedge 3 includes all five above ground levels and all five rings.

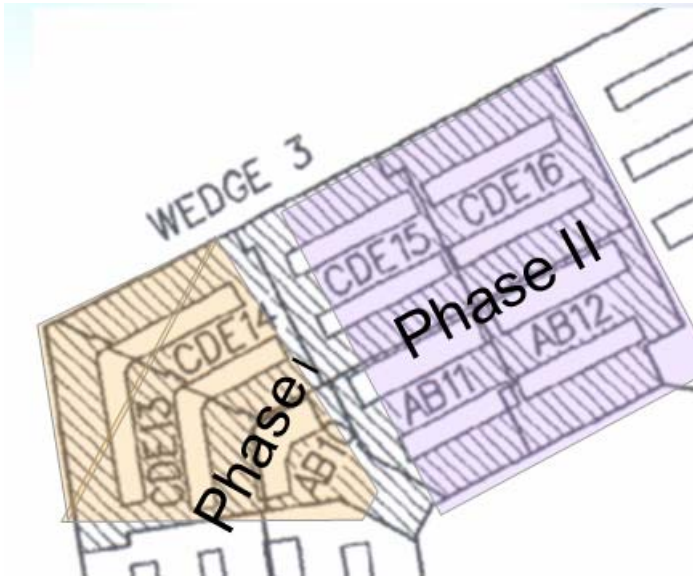

Corridors seven and eight will be discussed throughout the report, Corridor seven is along the left side of phase I, will Corridor 8 is between Phase I and Phase II.

The ten bays are shown to the right, labeled "bays 100", "bays 200", etc, until the last "bay 1000". Wedge 3 belongs to the 700, 800 and a section of the 900 bays.

Now, the reader should be generally oriented to the regions discussed.

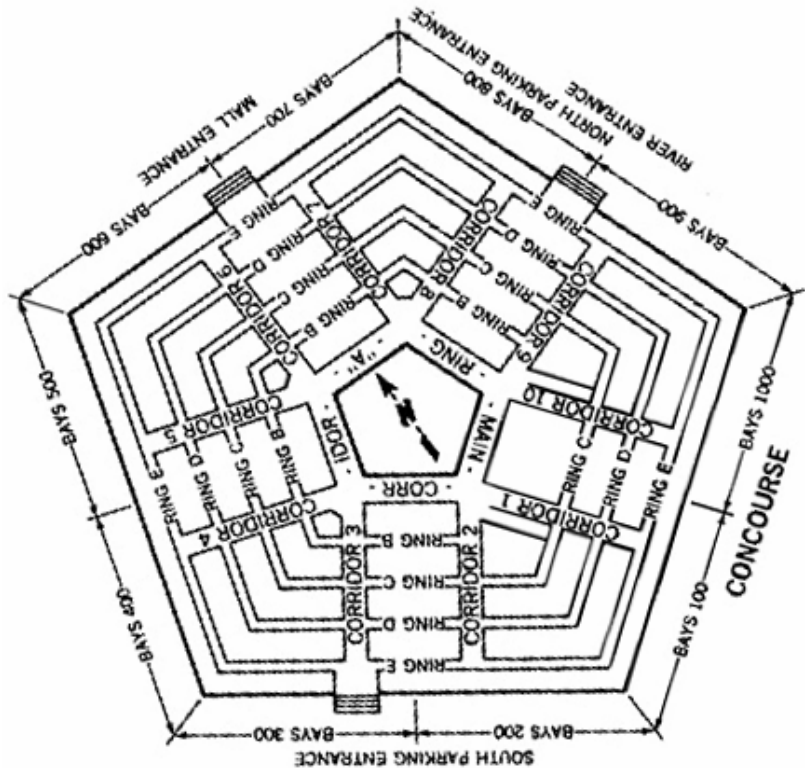



Analysis 1 Table of Contents

Introduction	1.2
Environmental Problems	
<i>Heat Island.....</i>	<i>1.2</i>
<i>Energy Costs.....</i>	<i>1.3</i>
<i>Water table and Watersheds.....</i>	<i>1.3</i>
<i>The Green Roof Solution.....</i>	<i>1.4</i>
Design Considerations	
<i>Green Roof Types.....</i>	<i>1.4</i>
<i>Extensive Green Roof on the Pentagons</i>	<i>1.4</i>
<i>Design Details</i>	<i>1.5</i>
Final Design	
<i>Details</i>	<i>1.6</i>
<i>Drainage.....</i>	<i>1.10</i>
<i>LEED Points.....</i>	<i>1.11</i>
<i>Size Estimate</i>	<i>1.12</i>
Structural Breadth	
<i>Roof Slab Calculations.....</i>	<i>1.13</i>
Costs	
<i>Green Roof Cost Summary Table</i>	<i>1.16</i>
Conclusions	1.16



Green Roofing

This analysis determines the feasibility of implementing a green roof system at the Pentagon, namely for Wedge 3 which is currently under construction. This system would be placed on top of the existing roof.

Introduction

As the world becomes more cluttered with evidence of human civilization, the effects of buildings and energy consumption on the environment become blatantly more obvious. Issues such as suffering water tables, exhaustion of natural resources and energy sources, and heat island effects plague urban areas in an upsetting foreshadow of a bleak future. However, the health of our environment is not destined for disaster; ecologists, engineers and others are not only aware that changes must be made, but many of these changes are already in implementation.

One earth-friendly solution is the implementation of green roof systems. The following problem section will discuss three important environmental issues, the way in which the Pentagon structure contributes to the negative effects, and ways in which implementing a green roof could reduce the impact

Problems

Heat Island

A heat island occurs in urban areas, and the phenomenon causes average temperatures to be up to six to eight degrees hotter in the city than in the surrounding suburbs and rural regions. This occurs because of heat absorbed by pavement, concrete and other dark building materials replaces the natural water and vegetations.

The Pentagon Reservation is 583 acre complex. The 6.5 million square foot structure covers twenty-nine acres with a five acre courtyard in the center. The reservation itself and its' infrastructures are expansive enough to cause a serious heat island effects including smog in Arlington, VA.

Pentagon Renovation Wedge 3



Arlington, VA

Some factors contributing to this heat island effect at the Pentagon Reservation are:

Parking	67 acres
Highway access	31 miles
Overpasses and bridges	21 miles
Sewage plant	1 acre
Heating and refrigeration plant	1 acre

Energy Costs

The interior volume of the Pentagon is equivalent to three empire state buildings. The massive amount of air requires heating, cooling and circulation just as any other building, all of which results in excessive energy consumption. The electric bill alone for the pentagon is an astounding \$1.1 million per month. The renovation currently underway inside the building includes centralized heating and cooling systems with zonal control that may reduce this energy consumption by up to 40%, yet more can still be done.

Though the technology is relatively new and limited long-term cost saving data is unavailable, it is still estimated that green roofs may reduce energy costs up to 30%.

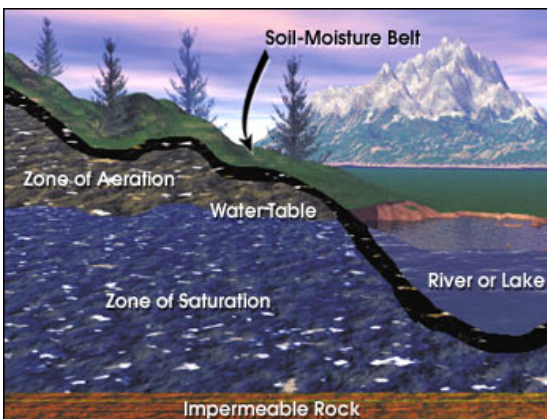

Water tables and water sheds

A water table is the upper limit of abundant ground water (http://en.wikipedia.org/wiki/Water_table), or more simply, the area underground that is saturated with water. The diagram gives a visual of a water table. A water shed is the area drained by a stream and all of its tributaries. Pollution in one stream or

underground water system may affect all areas downstream from the site of the pollution. The Pentagon lies near the end of the Chesapeake Bay watershed, one of the largest and most vulnerable watershed regions.

Advisor: Dr. Riley

Julie Rankin
Construction Management



When a large area such as the Pentagon reservation sprawls over the earth with impermeable surfaces like concrete and asphalt, rainwater and runoff water cannot penetrate into the ground to refresh the water table below. This in turn affects the entire watershed.

The Green Roof Solution

It is possible to add a green roof to any existing structure, if the proper steps are taken to ensure the structural soundness of the roof and the availability of drainage and the other necessities for the roof. There are environmental, economical and aesthetic benefits to this type of construction.

Green roofs allow heat to be pulled from the building in the summer to reduce cooling bills, and serve to insulate a building during winter months. According to emerging studies, these costs may be cut by up to twenty five percent. Green roofs also serve to elongate the life of the roof by up to fifty percent. Rainwater is used for the vegetation on the roof, thus reducing runoff in improper areas. The water can also be collected and drained from the green roof and reused for watering other gardens or returned to the earth naturally.

Design Considerations

Green Roof Types

Often green roofs are categorized into two types, intensive and extensive. An *intensive* green roof often doubles as a public space for people to enjoy. These roofs will have grass, shrubs and trees and may sustain loads of about 80 – 150 pounds per square foot. However, *extensive* green roofs are not commonly intended for public access, but aim to achieve purely ecological advantages. They use much lighter vegetation and are designed to require minimum maintenance. Even sod and grasses are often considered time-intensive for maintenance, causing plugs of vegetation to be the most common.

The design of the green roof will be dictated by the limitations of the existing roof. The green design should have a relatively light load and will not be used as an



outdoor recreation space for people, thus a thin ecological cover. Because of this and other factors that would prohibit pedestrians and employees at the Pentagon from enjoying roof gardens, this roof would be an extensive design.

Extensive green roof on the Pentagon

Extensive roofs may be placed on flat roofs, though the ideal system has at least a five percent slope for natural drainage, (the maximum practical slope is a forty five degree angle). The inner and outer-most rings, A and E, have a pitched slate roof, a material that can not support a green roof and must remain for aesthetic reasons. For this reason and also to protect the neo-classical aesthetic of the Pentagons design when viewed from both the outside and from the central courtyard, A and E will not be considered in the plan. Yet rings B, C, and D are flat tar and gravel roofs. Also, to create the most practical design, only the concentric rings, the areas between the lightwells of B, C and D, will be considered for the green roof, and not the radial corridors. These radial corridors also have the pitched slate roof. The existing roof slabs are approximately five to six inches thick.



It is more practical to exclude areas AB10, CDE13 and CDE14 (known as Phase I) because of the radial slate roof that runs through the center of it. Therefore, the roof will be designed for Phase II, shown here darkened. Rings B.C. D are shaded a transparent green  to show where the green roof would be.

Pentagon Renovation Wedge 3



Arlington, VA

Final Design

Details

The minimum components of a green roof are waterproofing, drainage, growth media and plants, but insulation though optional is highly recommended with the system. The section view below shows the layers to the extensive green roof design that selected for this application.

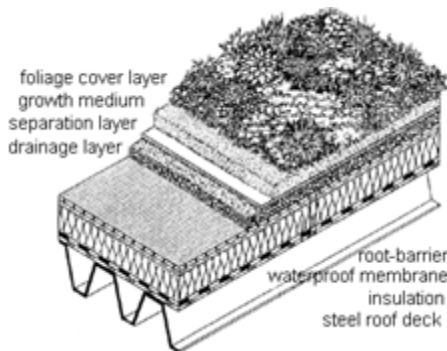

While there is always typical drainage layer, it will be necessary to add a filtration layer as well because the roof here is flat.

Extensive Green Roofs

1. Roof deck, Insulation, Waterproofing
2. Protection and Storage Layer
3. Drainage and Capillarity Layer
4. Root permeable Filter Layer
5. Extensive Growing Media
6. Plants, Vegetation

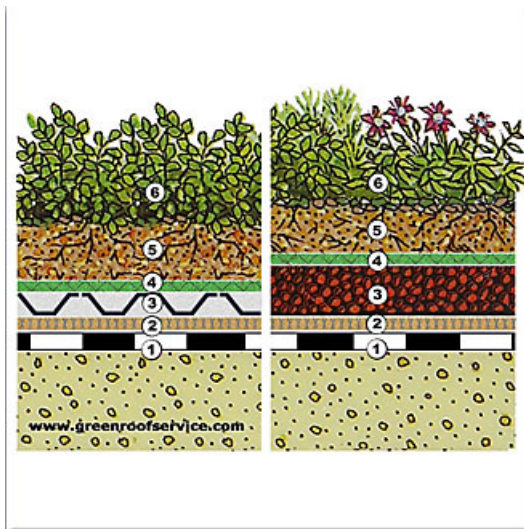

The proposed design includes an ecological green cover, without the necessity of public access. The existing vaults would remain as the primary access to the roof for maintenance.

Advisor: Dr. Riley

1. 6

Julie Rankin
Construction Management

Pentagon Renovation Wedge 3



Arlington, VA

The selected plants are *Sedum acre* "Aureum" and *Sedum spurium* "John Creech". Both plants are hardy, and tolerant of winter weather, as well as drought conditions. These plants will likely need little maintenance to thrive.

Sedum acre "Aureum"

- **Botanical Name:** *Sedum acre* 'Aureum'
- **Hardiness Zone:** 4
- **Heat Zone:**
- **Flower Color:** Yellow
- **Bloom Time:** May-June
- **Winter Interest:** Yes
- **Height:** 3"
- **Spread:** 10"
- **Drought Tolerance:** Very High
- **Moisture Tolerance:** High
- **Shade Tolerance:** Very High



Sedum spurium "John Creech"

- **Botanical Name:** *Sedum spurium* 'John Creech'
- **Hardiness Zone:** 5
- **Heat Zone:** 3-7
- **Flower Color:** Pink
- **Bloom Time:** July-August
- **Foliage Color:** Green
- **Winter Interest:** No
- **Height:** 4"
- **Spread:** 10"
- **Drought Tolerance:** Very High
- **Moisture Tolerance:** Yes
- **Shade Tolerance:** Yes
- **N. American Native:** No

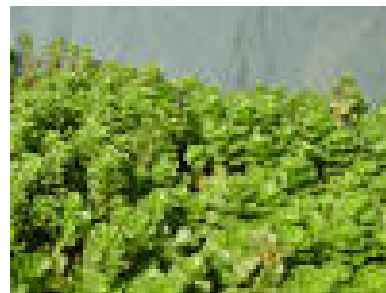
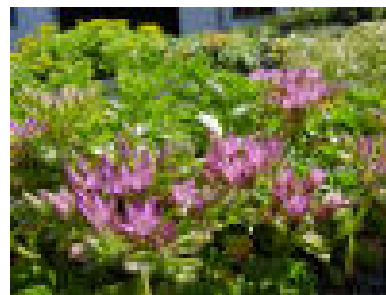

Pentagon Renovation Wedge 3



Arlington, VA

There are four typical types of systems with drainage plates, which is necessary to compensate for the flat roof. The selected one here is labeled P2, which will have a load of 23 lbs/ sf dry and 37 lbs/sf saturated.

SYSTEMS WITH DRAINAGE PLATES			
P1	P2	P3	P4
sedum herbs	sedum herbs perennials	perennials grasses shrubs	grasses shrubs trees
3"	5"	-	-
-	-	8"	12"
1/8"	1/8"	1/8"	1/8"
-	-	-	-
1"	1-1/2"	1-1/2"	2-1/2"
-	-	-	-
1/4"	1/4"	1/4"	1/4"
4"	7"	10"	15"
14 lbs/ft ²	23 lbs/ft ²	34 lbs/ft ²	52 lbs/ft ²
23 lbs/ft ²	37 lbs/ft ²	57 lbs/ft ²	85 lbs/ft ²
1/4:12	1/4:12	1/4:12	1/4:12
1:12	1:12	1:12	1:12
50%	60%	70%	80%
-	-	surface	surface

(800) 477-7724



system designation	P2
typical plants	sedum herbs perennials
extensive soil mix	5"
intensive soil mix	-
separation fabric	1/8"
granular drainage	-
drainage plate	1-1/2"
drainage mat	-
protection mat	1/4"
nominal thickness	7"
dry weight	23 lbs/ft ²
saturated weight	37 lbs/ft ²
minimum slope	1/4:12
maximum slope	1:12
water retention	60%
irrigation system	-



Adding the layers of a green roof will add considerable load to the roof. Therefore, the existing roof system must be structurally analyzed to determine its maximum weight loads. Snow loads must also be considered with these calculations. The roof is a one-way slab system resting on the columns beneath it. Beams connect the columns in both the lateral and transverse directions. If the existing roof is not sufficient to support a green roof, methods to reinforce the slab for extra strength will be designed.

The first critical issue is determining the structural loads of the existing roof and determining the maximum possible loads the structure can hold. From this, it can be determined the maximum possible weight the roof system, including the water weight it will retain in a saturated state. If the load is too high, or even at an unsafe level, solutions for adding strength to the system will be researched.

One way to assist in the loading of a green roof is known as point loading, where the heaviest parts of the green roof are placed over existing beams and points where the roof is most sound. Another possibility is the addition of a steel reinforcement underneath the roof slab.

Drainage from the roof is also a problem which must be researched. Fortunately, the scope of Wedge 3 involves replacing the gutter and roof drainage systems already; therefore it should be of little effort to resolve this issue.

Another area of interest is the cost and time of initial setup versus the potential long-term benefits that a green roof might offer.

Pentagon Renovation Wedge 3



Arlington, VA

Drainage

The roof drains water through piping that runs vertically down the sides of the building. These pipes are hidden behind the limestone masonry and concrete facades.

The roof already has a built-in gutter system in the plan that is large enough to sustain drainage from the green roof. During heavy rains, the plant growth and drainage layers will actually slow the flow of rainwater in the gutters, preventing overflow and serious runoff issues.

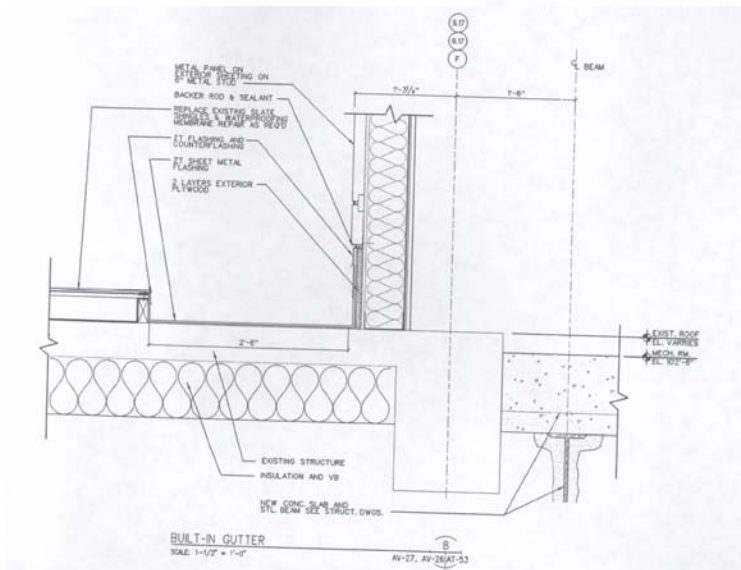
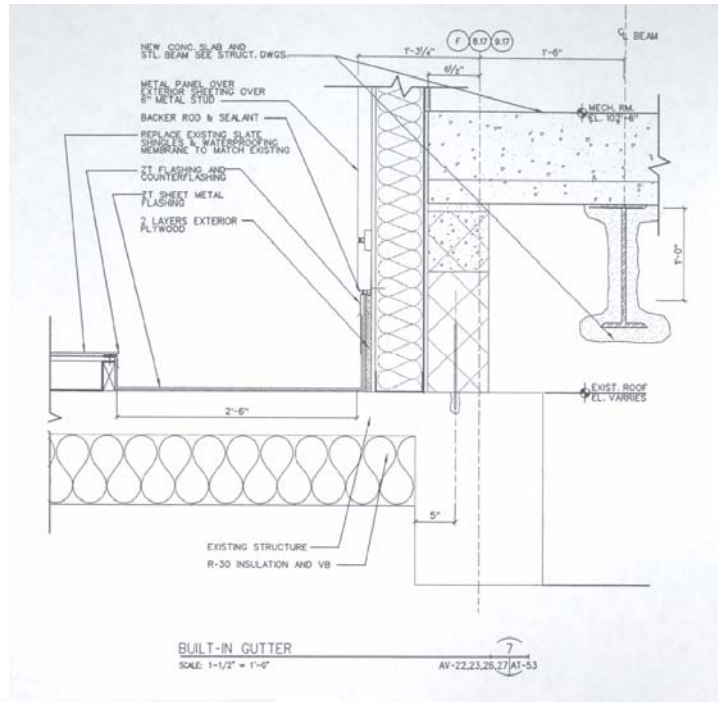

These images are details for the built-in gutter system, which is a 2.5' trough around the roof edges.

Pentagon Renovation Wedge 3



Arlington, VA

In the event that there would be an extensive amount of rainfall, the roof has overflow scuppers already in existence. Installing new scuppers as detailed below is already included in the scope of work for Wedge 3.

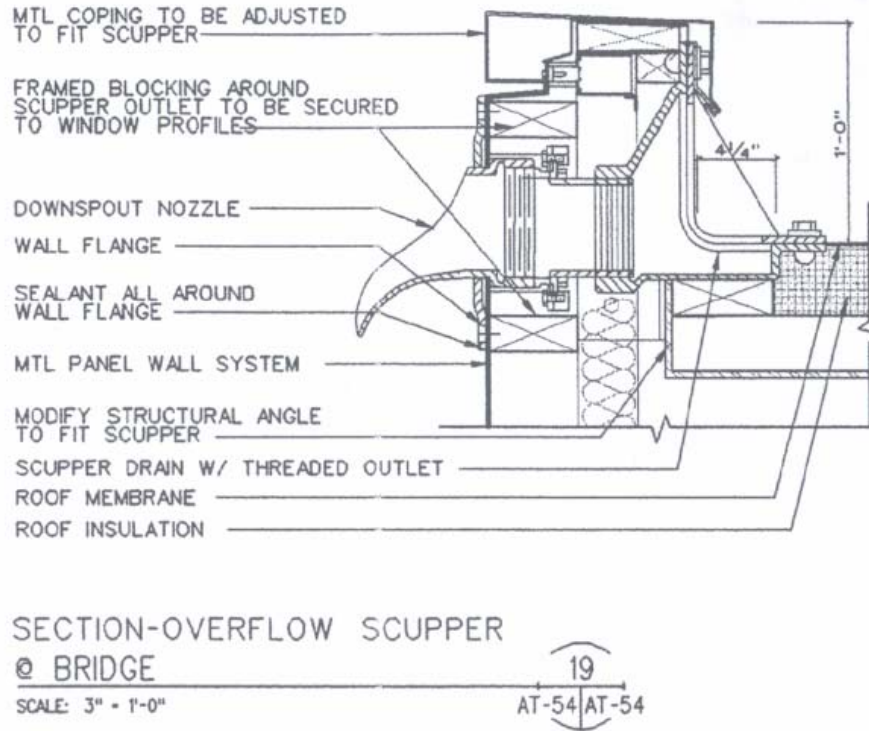

Article I.

Article II. LEED

This roof would contribute to several LEED points to assist in achieving a higher rating. One point is awarded for each of the following:

- Sustainable Sites (SS) credit 7.2 Urban Heat Island Reduction
- Storm water Management (SS) credit 6.1
- Storm water Treatment (SS) credit 6.2

Pentagon Renovation Wedge 3



Arlington, VA

Section 2.01 Size Estimate

When designing the green spaces on the roof, there was a two foot walkway left around the edges of the roof, as well as at expansion joints. These will serve as walkways. Also, stepping-stones pavers may be placed on other parts for maintenance walkway space. The green roof was divided into nine sections because of the location of expansion joints. The following images show each section and the square footage.

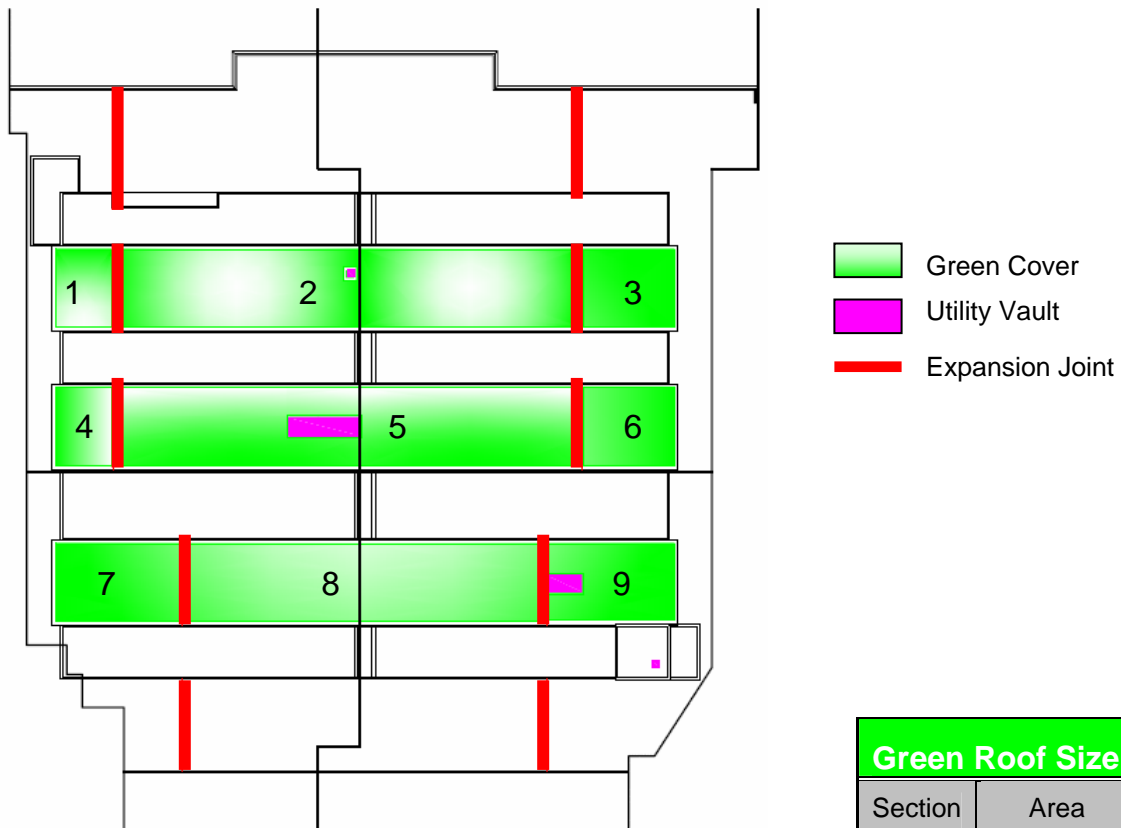

Green Roof Size	
Section #	Area (sf)
1	1462.5
2	11996.0
3	2362.5
4	1462.5
5	11501.0
6	2362.5
7	3262.3
8	9360.0
9	2950.0
Totals	46719.3



Solution Method

To analyze the structural loads, the typical calculations for the dead load on the existing roof will be performed. Then various roof weights for the load of the green roof will be added to see if the structure is still sound. Included in the load calculations will be the addition of the water weight. This maximum water weight varies depending upon the type of green roof soil layer chosen.

From these loads, it can be determined if the existing roof is strong enough, or if additional support must be added.

Structural Calculations

- Design for minimum reinforcement ($\rho \geq 0.0018bh$)
- 5" slab
- #4 @ 12" o.c. bottom
- #6 @ 12" o.c. top
- $f'_c = 3,000$ psi
- Span = 20'

End span



Interior Span



Expansion Joint – Treat as 2 End Spans

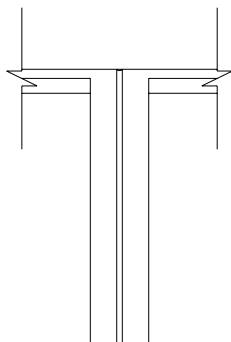



Load capacity for typical end span

Flexure

$$\Phi M_n = \Phi A_s f_y (d - a/2)$$

$$A_s = (12''/12'') * (0.2 \text{ in}^2) = 0.2 \text{ in}^2$$

$$a = \Phi A_s f_y / (0.85 f_c' b) = (0.2 \text{ in}^2 * 60) / (0.85 * 3 \text{ ksi} * 12'') = 0.39 \text{ in}$$

$$d = 5'' - 0.5 \text{ in} / 2 - 1'' = 3.75''$$

$$\Phi M_n = \Phi A_s f_y (d - a/2)$$

$$= 0.9 * 0.2 \text{ in}^2 * 60 (3.75'' - 0.39''/2) = 38.39 \text{ ft-kips/ft}$$

$$M_U = (w_U \ell_U^2) / 11$$

$$(w_U \ell_U^2) / 11 = 38.39 \text{ ft-kips/ft}$$

$$w_U = (38.39 \text{ ft-kips/ft}) / ((20')^2 / 11) = 1.056 \text{ klf}$$

Positive ΦM_n governs flexural capacity, $w_U = 1,056 \text{ psf}$

Shear

$$\text{Design Shear Strength} = \Phi V_c = 2\Phi (\sqrt{f_c'}) b_w d$$

$$= 2(0.85) (\sqrt{3000 \text{ psi}}) (14'')(20'') / 1000 = 26.07 \text{ kips/ft}$$

$$V_u = \Phi V_c$$

$$V_u = 1.5 w_U (\ell_n / 2 - d)$$

$$= 1.5 w_U (20/2 - 3.75'') = 26.07 \text{ kips/ft}$$

$$w_U = 2.78 \text{ klf} = 2,780 \text{ psf}$$

END SPAN : FLEXURAL CAPACITY OF ROOF GOVERNS

LOAD CAPACITY = 1,056 psf

Load capacity for typical interior span

Flexure

$$\Phi M_n = \Phi A_s f_y (d - a/2)$$

$$A_s = (12''/12'') * (0.2 \text{ in}^2) = 0.2 \text{ in}^2$$

$$a = \Phi A_s f_y / (0.85 f_c' b) = (0.2 \text{ in}^2 * 60) / (0.85 * 3 \text{ ksi} * 12'') = 0.39 \text{ in}$$

$$d = 5'' - 0.5 \text{ in} / 2 - 1'' = 3.75''$$

Pentagon Renovation Wedge 3



Arlington, VA

$$\begin{aligned}\Phi M_n &= \Phi A_s f_y (d - a/2) \\ &= 0.9 * 0.2 \text{ in}^2 * 60 (3.75'' - 0.39''/2) = 38.39 \text{ ft-kips/ft}\end{aligned}$$

$$M_U = (w_U \ell_U^2)/11$$

$$(w_U \ell_U^2)/11 = 38.39 \text{ ft-kips/ft}$$

$$w_U = (38.39 \text{ ft-kips/ft}) / ((20')^2/11) = 1.056 \text{ klf}$$

Top bars

$$M_U = \Phi M_n$$

$$= 0.9 * 0.528 \text{ in}^2 * 60 (3.75'' - 0.39''/2) = 101.36 \text{ ft-kips/ft}$$

$$M_U = (w_U \ell_U^2)/11$$

$$(w_U \ell_U^2)/11 = 101.36 \text{ ft-kips/ft}$$

$$w_U = 2.787 \text{ klf}$$

Negative ΦM_n governs flexural capacity, $w_U = 1,056$ psf

Shear

$$\text{Design Shear Strength} = \Phi V_c = 2\Phi (\sqrt{f_c'}) b_w d$$

$$= 2(0.85) (\sqrt{3000 \text{ psi}}) (14'')(20'') / 1000 = 26.07 \text{ kips/ft}$$

$$V_u = \Phi V_c$$

$$V_u = 1.5 w_U (\ell_n/2 - d)$$

$$= 1.5 w_U (20/2 - 3.75'') = 26.07 \text{ kips/ft}$$

$$w_U = 2.78 \text{ klf} = 2,780 \text{ psf}$$

INTERIOR SPAN : FLEXURAL CAPACITY OF ROOF GOVERNS

$$\text{LOAD CAPACITY} = 1,056 \text{ psf}$$

With the weight of the roof and the 37 lbs/sf saturated weight of the green roof, the slab is sufficient to hold the weight.

With 30 psf added for snow load, the roof is still sufficiently strong.



Cost

Another problem with green roof systems is that they tend to be costly, at about three times the cost of building a typical roof. In a scope where the roof of Wedge 3 needs only repair, it will greatly extend the cost of the project to install this roof.

Cost Summary Table			
Section #	Perimeter (lf)	Area (sf)	Cost (US Dollar)
1	155.0	1462.5	19,743.75
2	626.0	11996.0	161,946.00
3	195.0	2362.5	31,893.75
4	155.0	1462.5	19,743.75
5	627.5	11501.0	155,263.50
6	195.0	2362.5	31,893.75
7	235.0	3262.3	44,041.05
8	506.0	9360.0	126,360.00
9	273.0	2950.0	39,825.00
Totals	2967.5	46719.3	\$630,710.55

Conclusions

After structural and design analysis, it has been concluded that it is feasible to construct a green roof along the flat roofs of Wedge 3. At \$630,710.55 initial cost, the 46719.3 sf green roof will assist in reducing heating and cooling loads over time in the building. Also all three LEED points may be attained with this implementation.



Analysis 2 Table of Contents

Access Floor

<i>Universal Space Plan</i>	2.2
<i>Expansion Joints</i>	2.3

Design

<i>Access Floor Selection Criteria</i>	2.4
<i>ConCore Panels</i>	2.4
<i>Ceiling Clearance</i>	2.9
<i>Square Foot Calculations</i>	2.10

Mechanical Breadth

<i>Problem Statement</i>	2.15
<i>Air Handling Requirements</i>	2.18
<i>Duct Plan</i>	2.19
<i>Existing Duct</i>	2.20
<i>Riser Alterations</i>	2.21
<i>Section</i>	2.24

Costs

<i>Access Floor Cost Summary Table</i>	2.25
--	------

Schedule Impact

<i>SIPS Schedule- Existing</i>	2.26
<i>SIPS Schedule- Revised</i>	2.27

Conclusions	2.30
--------------------------	------



Access Floor

Universal Space Plan

One major issue at the Pentagon is that there is often a need to renovate interior spaces after only a few years of use. Therefore, the more flexible general office spaces are, the easier and cheaper the adaptations will be.

The major function of rooms in Wedge 3 is general office space, and there are some areas with equipment and serving room functions. The universal space plan was designed to maximize daylight and reduce lighting costs. It involved running the mechanical and electrical systems through an overhead bulkhead in the center on the ceiling of each ring, with the window areas on either side being illuminated by outdoor light. The areas near windows had higher ceilings for more daylight.



The areas near windows had higher ceilings for more daylight.

It was assumed that reducing the space to an even more open plan would

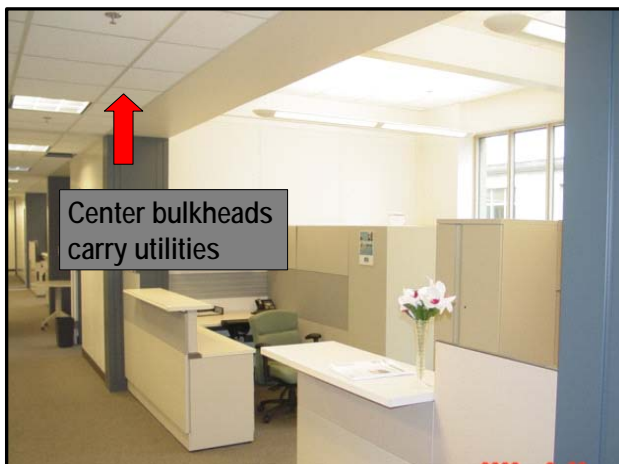

increase the flexibility further. This involves removing the overhead bulkhead in the center of each ring and keeping the ceiling open. This could be achieved by using access panel flooring and running all utilities below.

Pentagon Renovation Wedge 3



Arlington, VA

Expansion Joints

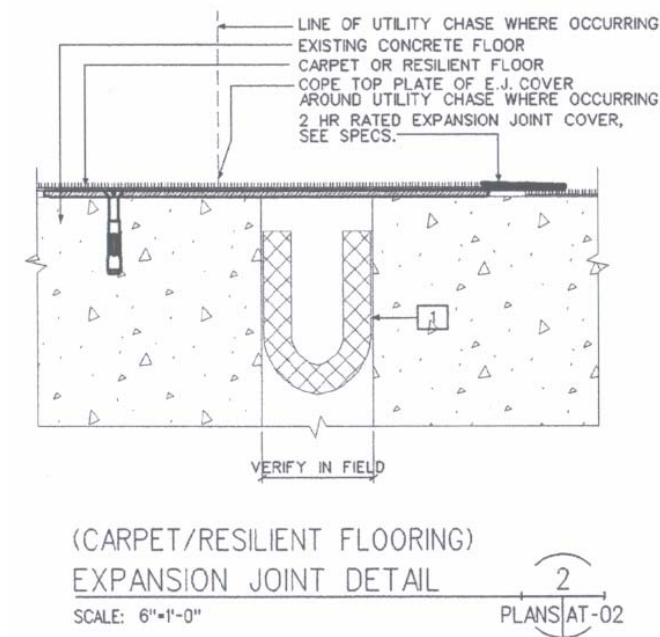

Another problem with the existing carpeted floor that could be solved by access panels is based around the expansion joints. During the renovation of Wedge 2, the carpet around several expansion joints "bubbled", or rose because of shifts in the building after the carpet was laid. In these situations, the carpet was removed and re-glued to the floor, yet over time, settling will guarantee that the carpets will again have problems at expansion joints.

These details compensate for the expansion joints' movement, but not for the carpet over it.

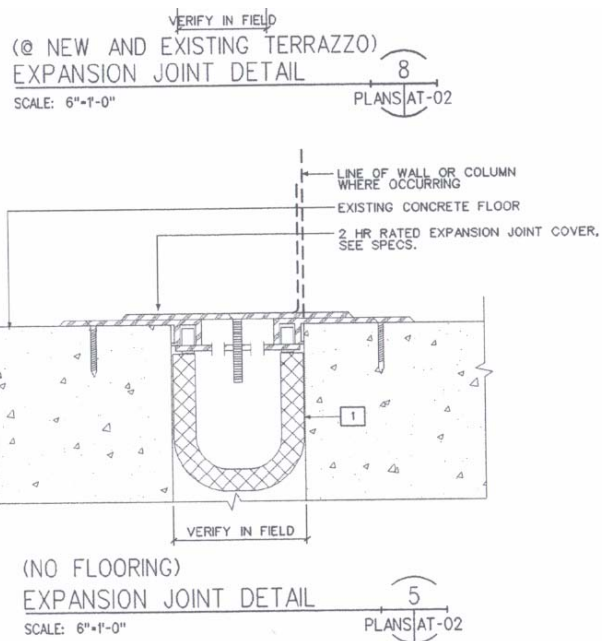



Design

Access Floor Selection Criteria

The floor types were determined based on the following criteria:

General Office Space

- Wall To Wall Floor Required
- Server racks, desks and PC's (< 1,000 pounds)
- Rolling Loads (> 1,000 pounds)
- Moderate Under Floor Wiring: large cables, telephone, electrical boxes

Design Selection: **ConCore1000**

Computer Room

- Wall To Wall Floor Required
- Large Computer Systems (< 1,250 pounds)
- Rolling Loads (> 1,000 pounds)
- Heavy Under Floor Usage : Serious cables and cable trays, junction boxes

Design Selection: **ConCore1250**

Control Room

- Wall To Wall Floor Required
- Industrial and Large Mainframes(> 1500 pounds)
- Rolling Loads (> 1,000 pounds)
- Heavy Under Floor Usage : Serious cables and cable trays, junction boxes

Design Selection: **ConCore1500**

ConCore Panels

ConCore panels were chosen for their excellent properties. They are fabricated from steel and filled with controlled mixtures of cement. They offer extremely high load tolerances, and create a solid floor system. The floor is also free from noises occurring in the plenum space.

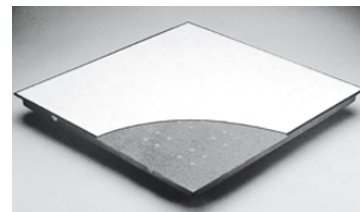



This chart summarizes the most commonly available ConCore access panels. It shows maximum static, rolling and impact loads, as well as the system total weight. This is the chart that was used to select the most appropriate panels for general office, control room and computer room spaces.

ConCore® Performance Selection Chart

SYSTEM TYPE		SYSTEM WEIGHT	STATIC LOADS			ROLLING LOADS		IMPACT LOADS
Panel	Understructure		Concentrated Loads	Uniform Loads	Ultimate Loads	10 passes	10,000 passes	
ConCore 1000	Bolted Stringer	9.5 lbs/ft ² 46 kg/m ²	1000 lbs 454 kg	250 lbs 113 kg	3300 lbs 1497 kg	800 lbs 363 kgs	600 lbs 272 kgs	150 lbs 68 kg
	Posilock	8.5 lbs/ft ² 41 kg/m ²	1000 lbs 454 kg	250 lbs 113 kg	3200 lbs 1452 kg	800 lbs 363 kg	600 lbs 272 kg	100 lbs 45 kg
ConCore 1250	Bolted Stringer	10.5 lbs/ft ² 51 kg/m ²	1250 lbs 567 kg	300 lbs 136 kg	3850 lbs 1746 kg	1000 lbs 454 kg	800 lbs 363 kg	150 lbs 68 kg
	Posilock	9.5 lbs/ft ² 46 kg/m ²	1250 lbs 567 kg	300 lbs 136 kg	3750 lbs 1701 kg	1000 lbs 454 kg	800 lbs 363 kg	100 lbs 45 kg
ConCore 1500	Bolted Stringer	11.5 lbs/ft ² 56 kg/m ²	1500 lbs 680 kg	375 lbs 170 kg	5100 lbs 2313 kg	1250 lbs 567 kg	1000 lbs 454 kg	150 lbs 68 kg
	Posilock	10.5 lbs/ft ² 51 kg/m ²	1500 lbs 680 kg	375 lbs 170 kg	4600 lbs 2087 kg	1250 lbs 567 kg	1000 lbs 454 kg	100 lbs 45 kg
ConCore 2000	Bolted Stringer	12.5 lbs/ft ² 61 kg/m ²	2000 lbs 907 kg	500 lbs 227 kg	6100 lbs 2767 kg	1500 lbs 680 kg	1250 lbs 567 kg	150 lbs 68 kg
ConCore 2500	Bolted Stringer	13.5 lbs/ft ² 66 kg/m ²	2500 lbs 1134 kg	625 lbs 284 kg	6900 lbs 3130 kg	1500 lbs 680 kg	2000 lbs 907 kg	150 lbs 68 kg

Note: Loads applied on a one square inch area. Results above indicate weakest point of panel.

Pentagon Renovation Wedge 3



Arlington, VA



ConCore® : CC1000 Panel-24"

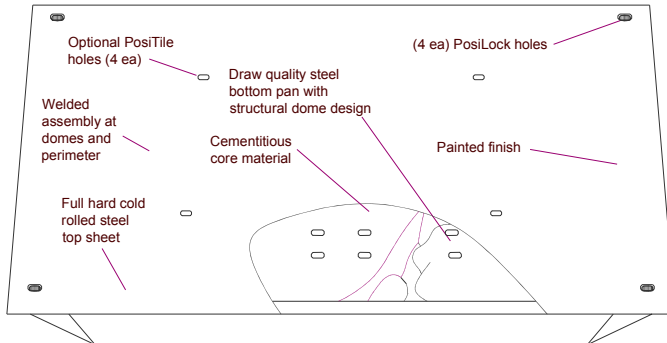

TOP VIEW

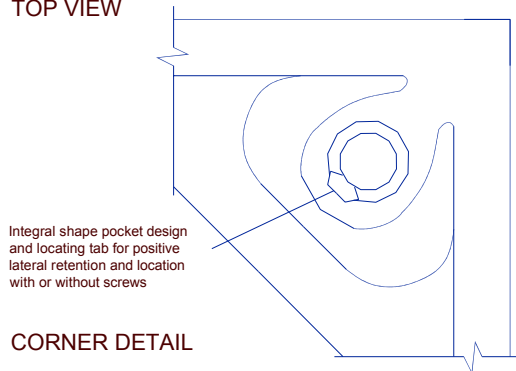

CORNER DETAIL



Tile w/ Top Set Trim



Tile w/ Integral Trim

SPECIFICATIONS

General information

- Panel weight : 7.5 lbs./ft² bare.
- 1-3/8 inches deep with no covering.
- All steel welded construction filled internally with a cementitious core material.
- Protected from corrosion by an epoxy paint finish.
- Class A flame spread rating.
- Non-combustible material.

UNDERSTRUCTURE OPTIONS

- Freestanding Posilock
 2' Bolted Stringer 4' Bolted Stringer

COVERING OPTIONS

Tile factory laminated with top set trim edge

- 1/16" HPL _____ (Color) _____
 1/16" Conductive HPL _____ (Color) _____
 1/8" HPL _____ (Color) _____
 1/8" Conductive HPL _____ (Color) _____
 1/8" VCT _____ (Color) _____
 1/8" Conductive Vinyl _____ (Color) _____
 1/8" Static Dissipative Vinyl _____ (Color) _____

Tile factory laminated with integral trim edge

- 1/8" HPL _____ (Color) _____
 1/16" HPL _____ (Color) _____
 1/8" Conductive HPL _____ (Color) _____
 1/16" Conductive HPL _____ (Color) _____

Bare Painted Panel Options

- Bare Painted Finish to accept carpet tile application
 Bare Painted Finish to accept PosiTile application

Performance Selection Chart

System Type	Understructure	SYSTEM WEIGHT	STATIC LOADS				ROLLING LOADS		IMPACT LOADS
			Concentrated Loads	Top Surface Deflection	Uniform Loads	Ultimate Loads	10 Passes	10,000 Passes	
ConCore CC1000-24"	Posilock	7.5 lbs / ft ² 37 kg / m ²	1000 lbs 454 kg	0.100" 2.54 mm	250 lbs / ft ² 11.9 kPa	3250 lbs	800 lbs 363 kg	600 lbs 272 kg	150 lbs 68 kg
	Bolted Stringer	9.0 lbs / ft ² 37 kg / m ²	1000 lbs 454 kg	0.100" 2.54 mm	250 lbs / ft ² 11.9 kPa	3000 lbs	800 lbs 363 kg	600 lbs 272 kg	150 lbs 68 kg

Concentrated, ultimate, and impact load capacities are tested by imposing loads on a one square inch area. Results indicate weakest point of panel.
 Permanent set after application of concentrated load shall be <0.010". Local and overall deformation after application of rolling loads shall be <0.040"

Tate Access Floors, Inc.
 7510 Montevideo Road
 Jessup, MD 20794
 Tel (410) 799-4200 Fax (410) 799-4207

© 2003 Tate Access Floors, Inc.

Pentagon Renovation Wedge 3



Arlington, VA



ConCore® : CC1250 Panel-24"

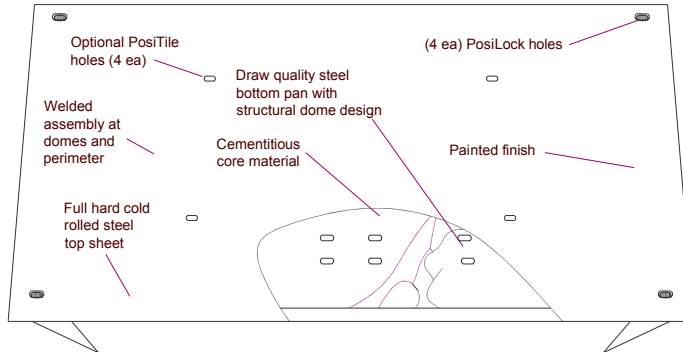

TOP VIEW

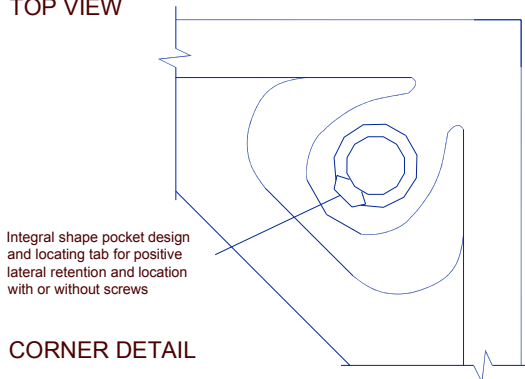

CORNER DETAIL



Tile w/ Top Set Trim



Tile w/ Integral Trim

SPECIFICATIONS

General information

- Panel weight : 8.0 lbs./ft² bare.
- 1-3/8 inches deep with no covering.
- All steel welded construction filled internally with a cementitious core material.
- Protected from corrosion by an epoxy paint finish.
- Class A flame spread rating.
- Non-combustible material.

UNDERSTRUCTURE OPTIONS

- Freestanding
- Posilock
- 2' Bolted Stringer
- 4' Bolted Stringer

COVERING OPTIONS

Tile factory laminated with top set trim edge

- 1/16" HPL _____ (Color) _____
- 1/16" Conductive HPL _____ (Color) _____
- 1/8" HPL _____ (Color) _____
- 1/8" Conductive HPL _____ (Color) _____
- 1/8" VCT _____ (Color) _____
- 1/8" Conductive Vinyl _____ (Color) _____
- 1/8" Static Dissapative Vinyl _____ (Color) _____

Tile factory laminated with integral trim edge

- 1/8" HPL _____ (Color) _____
- 1/16" HPL _____ (Color) _____
- 1/8" Conductive HPL _____ (Color) _____
- 1/16" Conductive HPL _____ (Color) _____

Bare Painted Panel Options

- Bare Painted Finish to accept carpet tile application
- Bare Painted Finish to accept PosiTile application

Performance Selection Chart

System Type	Understructure	SYSTEM WEIGHT	STATIC LOADS				ROLLING LOADS		IMPACT LOADS
			Concentrated Loads	Top Surface Deflection	Uniform Loads	Ultimate Loads	10 Passes	10,000 Passes	
ConCore CC1250-24"	Posilock	8.5 lbs / ft ² 41 kg / m ²	1250 lbs 567 kg	0.100" 2.54 mm	300 lbs / ft ² 14.3 kPa	3750 lbs	1000 lbs 454 kg	800 lbs 363 kg	150 lbs 68 kg
	Bolted Stringer	10.0 lbs / ft ² 49 kg / m ²	1250 lbs 567 kg	0.100" 2.54 mm	300 lbs / ft ² 14.3 kPa	3500 lbs	1000 lbs 454 kg	800 lbs 363 kg	150 lbs 68 kg

Concentrated, ultimate, and impact load capacities are tested by imposing loads on a one square inch area. Results indicate weakest point of panel.

Permanent set after application of concentrated load shall be <0.010". Local and overall deformation after application of rolling loads shall be <0.040"

Tate Access Floors, Inc.
7510 Montevideo Road
Jessup, MD 20794
Tel (410) 799-4200 Fax (410) 799-4207

© 2003 Tate Access Floors, Inc.

Pentagon Renovation Wedge 3



Arlington, VA



ConCore® : CC1500 Panel-24"

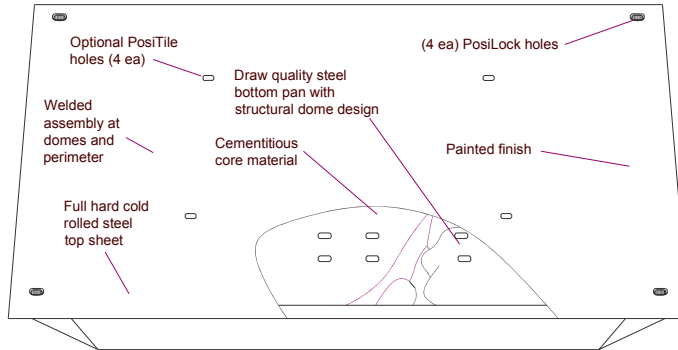

TOP VIEW

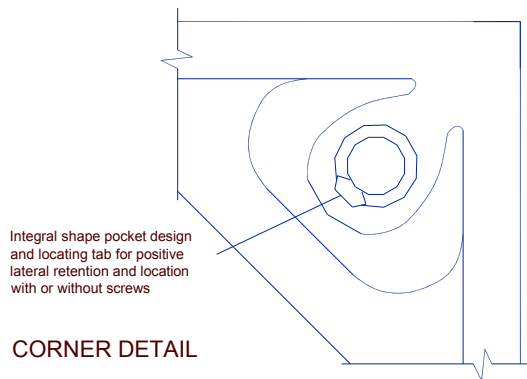

CORNER DETAIL



Tile w/ Top Set Trim

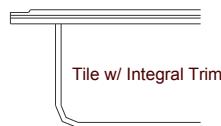

Tile w/ Integral Trim

SPECIFICATIONS

General information

- Panel weight : 9.0 lbs./ft² bare.
- 1-3/8 inches deep with no covering.
- All steel welded construction filled internally with a cementitious core material.
- Protected from corrosion by an epoxy paint finish.
- Class A flame spread rating.
- Non-combustible material.

UNDERSTRUCTURE OPTIONS

- 4' Heavy Duty Bolted Stringer
- 2' Heavy Duty Bolted Stringer

COVERING OPTIONS

Tile factory laminated with top set trim edge

- 1/16" HPL _____ (Color) _____
- 1/16" Conductive HPL _____ (Color) _____
- 1/8" HPL _____ (Color) _____
- 1/8" Conductive HPL _____ (Color) _____
- 1/8" VCT _____ (Color) _____
- 1/8" Conductive Vinyl _____ (Color) _____
- 1/8" Static Dissapative Vinyl _____ (Color) _____

Tile factory laminated with integral trim edge

- 1/8" HPL _____ (Color) _____
- 1/16" HPL _____ (Color) _____
- 1/8" Conductive HPL _____ (Color) _____
- 1/16" Conductive HPL _____ (Color) _____

Bare Painted Panel Options

- Bare Painted Finish to accept carpet tile application
- Bare Painted Finish to accept PosiTile application

Performance Selection Chart

System Type	Understructure	SYSTEM WEIGHT	STATIC LOADS				ROLLING LOADS		IMPACT LOADS
			Concentrated Loads	Top Surface Deflection	Uniform Loads	Ultimate Loads	10 Passes	10,000 Passes	
ConCore CC1500-24"	Bolted Stringer	10.5 lbs / ft² 52 kg / m²	1500 lbs 680 kg	0.100" 2.54 mm	375 lbs / ft² 17.9 kPa	5000 lbs	1250 lbs 567 kg	1000 lbs 454 kg	150 lbs 68 kg

Concentrated, ultimate, and impact load capacities are tested by imposing loads on a one square inch area. Results indicate weakest point of panel.

Permanent set after application of concentrated load shall be <0.010". Local and overall deformation after application of rolling loads shall be <0.040"

Tate Access Floors, Inc.
7510 Montevideo Road
Jessup, MD 20794
Tel (410) 799-4200 Fax (410) 799-4207

© 2003 Tate Access Floors, Inc.



Ceiling Clearance

Because the concrete work was done quickly, and with little attention to detail compared to today's standards, many of the floor-to-ceiling heights vary throughout the building. However, for stories two through four, the typical ceiling height is about 11'-6".

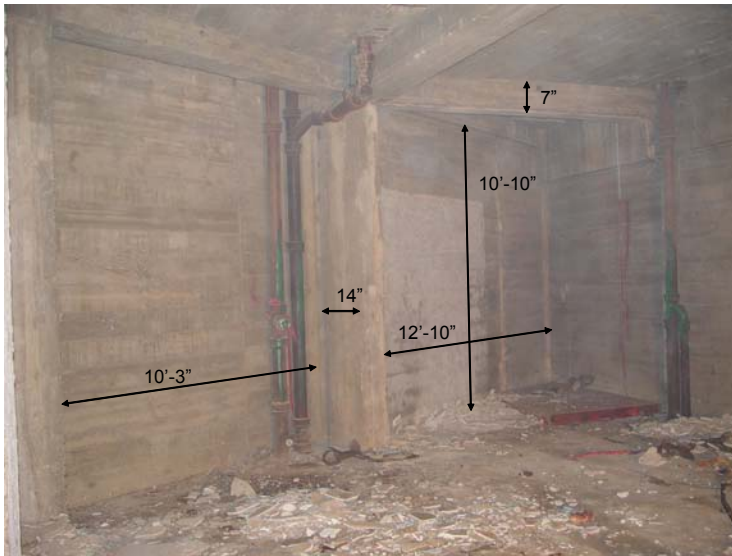

As shown in the figure, a seven inch beam from the ceiling offers a 10'-10" space beneath. If the panels are set 18" off the ground and a gypsum board ceiling or other ceiling type is installed flush with the under-slung beams, there is still a clearance of 9'-2", more than ample for the office spaces and computer rooms. If the air is returned

through an overhead plenum in drop ceiling, this ceiling height may still be very shallow. If it were 8", there is still over 8' clearance for usable space, and plenty of room in the overhead plenum for the plumbing.

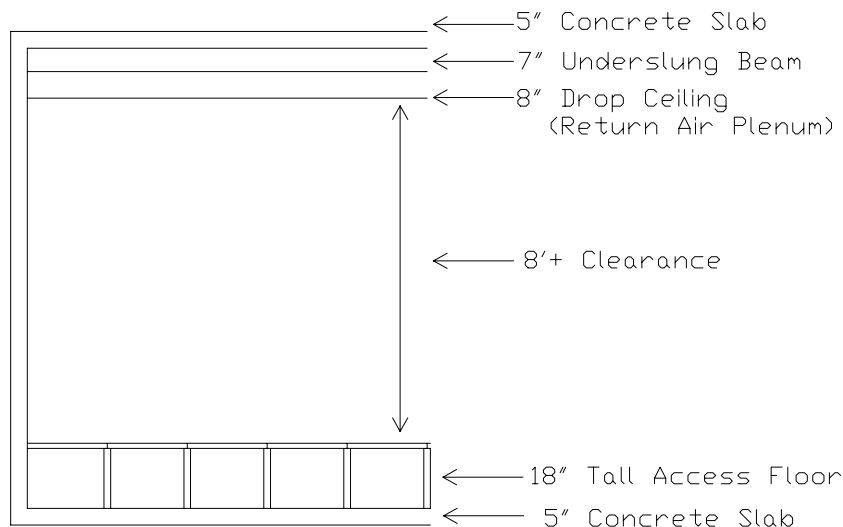

Pentagon Renovation Wedge 3



Arlington, VA

Square Feet Calculations

3rd Floor

AREA		AB11 - 3rd Floor	
Gross		16,830	sf
Subtractions	Perimeter	554	
	Columns	108	
	Shafts	172	
	Interior Walls	207	
	Stairs	220	
	Control Room		
Room	Telecommunications	345	
	Electrical Closets	200	
	Mechanical Closets	74	
Total	General Office	11,960	sf
		2,990	sf
		619	sf

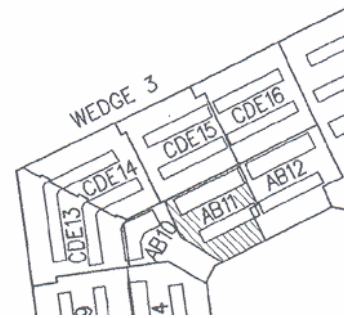

AREA		AB12 - 3rd Floor		
Total		18,020	sf	
Subtractions	Perimeter	588		
	Columns	108		
	Shafts	363		
	Interior Walls	90		
	Stairs	0		
	Telecommunications	364		
	Electrical Closets	200		
	Mechanical Closets	207		
	Unspecified	720		
	Total	General Office	12,304	sf
		Computer Room	3,076	sf
Control Room		1,491	sf	

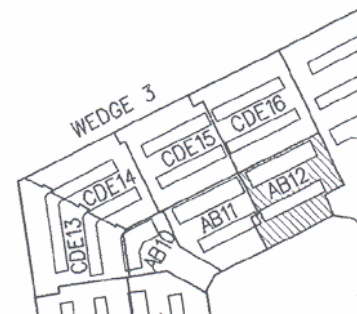

AREA		CDE15 - 3rd Floor	
Total		17,210	sf
Subtractions	Perimeter	630	
	Columns	216	
	Shafts	156	
	Interior Walls	0	
	Stairs	520	
	Telecommunications	756	
	Electrical Closets	320	
	Mechanical Closets	170	
	Unspecified	255	
	Total	General Office	11,350
Computer Room		2,837	sf
Control Room		1,501	sf

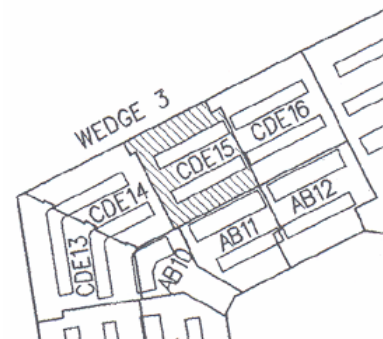

Pentagon Renovation Wedge 3



Arlington, VA

3rd Floor Continued

AREA		CDE16 - 3rd Floor	
Total		9,500	sf
Subtractions	Perimeter	960	
	Columns	216	
	Shafts	304	
	Interior Walls	0	
	Stairs	0	
	Telecommunications	744	
	Electrical Closets	340	
	Mechanical Closets	509	
	Unspecified	400	
	Total	General Office	4,822
Computer Room		1,205	sf
Control Room		1,993	sf

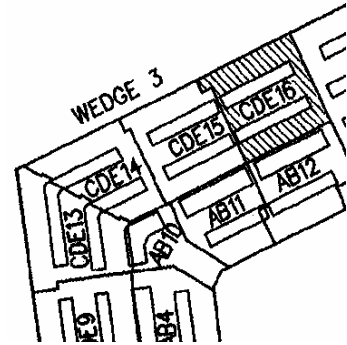

4th Floor

AREA		AB11 - 4th Floor	
Total		10,540	sf
Subtractions	Perimeter	410	
	Columns	108	
	Shafts	40	
	Interior Walls	0	
	Stairs	220	
	Telecommunications	345	
	Electrical Closets	200	
	Mechanical Closets	74	
Total	General Office	7,642	sf
	Computer Room	1,911	sf
	Control Room	619	sf

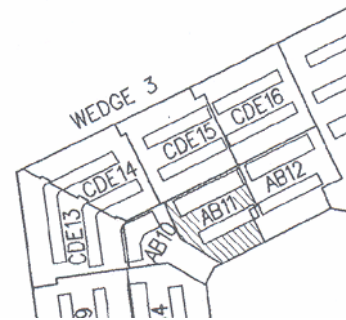

AREA		AB12 - 4th Floor	
Total		10,200	sf
Subtractions	Perimeter	508	
	Columns	108	
	Shafts	90	
	Interior Walls	90	
	Stairs	0	
	Telecommunications	364	
	Electrical Closets	200	
	Mechanical Closets	207	
	Unspecified	720	
	Total	General Office	6,330
Computer Room		1,583	sf
Control Room		1,491	sf

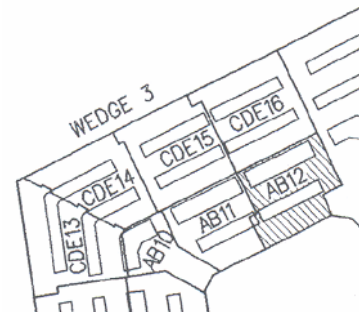

Pentagon Renovation Wedge 3



Arlington, VA

4th Floor Continued

AREA		CDE15 - 4th Floor	
Total		17,210	sf
Subtractions	Perimeter	630	
	Columns	216	
	Shafts	156	
	Interior Walls	0	
	Stairs	520	
	Telecommunications	756	
	Electrical Closets	320	
	Mechanical Closets	170	
	Unspecified	255	
	Total	General Office	11,350
Computer Room		2,837	sf
Control Room		1,501	sf

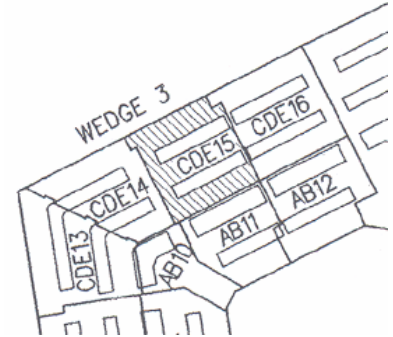

AREA		CDE16 - 4th Floor	
Total		9,500	sf
Subtractions	Perimeter	960	
	Columns	216	
	Shafts	304	
	Interior Walls	0	
	Stairs	0	
	Telecommunications	744	
	Electrical Closets	340	
	Mechanical Closets	509	
	Unspecified	400	
	Total	General Office	4,822
Computer Room		1,205	sf
Control Room		1,993	sf

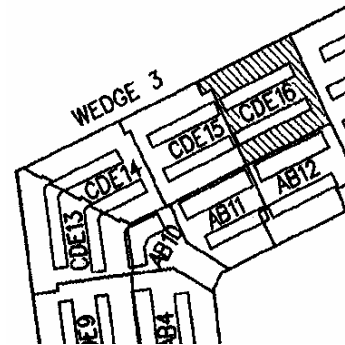

5th Floor

AREA		AB11 - 5th Floor	
Total		10,540	sf
Subtractions	Perimeter	410	
	Columns	108	
	Shafts	40	
	Interior Walls	0	
	Stairs	220	
	Telecommunications	345	
	Electrical Closets	200	
	Mechanical Closets	74	
Total	General Office	7,642	sf
	Computer Room	1,911	sf
	Control Room	619	sf

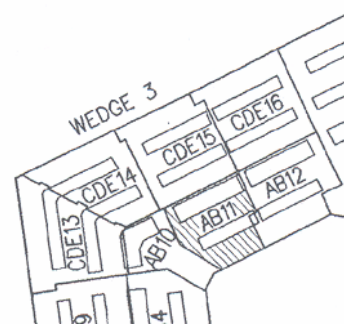

Pentagon Renovation Wedge 3



Arlington, VA

5th Floor Continued

AREA		AB12 - 5th Floor	
Total		10,200	sf
Subtractions	Perimeter	508	
	Columns	108	
	Shafts	90	
	Interior Walls	90	
	Stairs	0	
	Telecommunications	364	
	Electrical Closets	200	
	Mechanical Closets	207	
	Unspecified	720	
	Total	General Office	6,330
Computer Room		1,583	sf
Control Room		1,491	sf

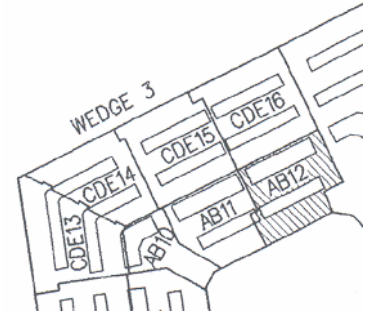

AREA		CDE15 - 5th Floor	
Total		17,210	sf
Subtractions	Perimeter	630	
	Columns	216	
	Shafts	156	
	Interior Walls	0	
	Stairs	520	
	Telecommunications	756	
	Electrical Closets	320	
	Mechanical Closets	170	
	Unspecified	255	
	Total	General Office	11,350
Computer Room		2,837	sf
Control Room		1,501	sf

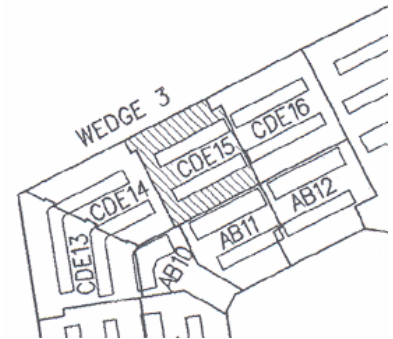

AREA		CDE16 - 5th Floor	
Total		9,500	sf
Subtractions	Perimeter	960	
	Columns	216	
	Shafts	304	
	Interior Walls	0	
	Stairs	0	
	Telecommunications	744	
	Electrical Closets	340	
	Mechanical Closets	509	
	Unspecified	400	
	Total	General Office	4,822
Computer Room		1,205	sf
Control Room		1,993	sf

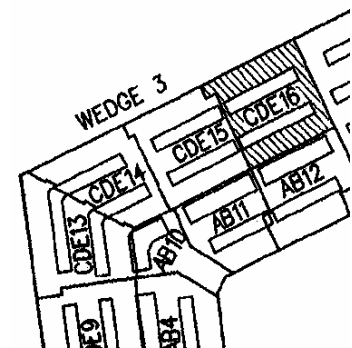

Pentagon Renovation Wedge 3



Arlington, VA

Total Square Footages

WEDGE 3		TOTALS
Subdivisions	General Office	100,723
	Computer Room	25,181
	Control Room	16,812
Total		142,716 sf



Mechanical Breadth

Problem Statement

As shown in the beginning of this section, the utilities including the treated air are delivered through an overhead bulkhead in several of the office areas. The air is delivered overhead, and the return grills are also located overhead in the same ceiling. There are some problems associated with this. If the air is supplied and returned from the ceiling, there may not be optimal circulation. This is especially so in the winter, when the warm treated air will stay near the ceiling, potentially causing drafts or less than optimal comfort.

I think that with a raised floor, it would be more efficient to deliver the air from the floor near the windows and have the return air go through the ceiling in the center.

The following diagram demonstrates the logic of the analysis by showing the probable air circulation from each system.

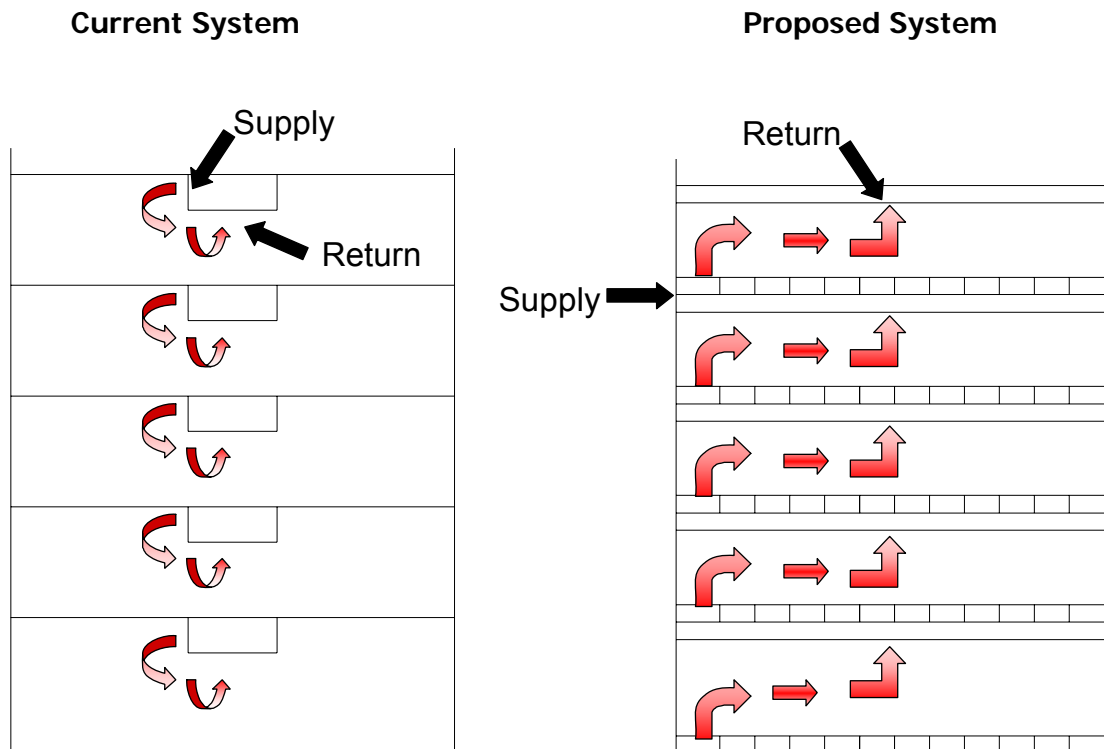

Pentagon Renovation Wedge 3



Arlington, VA

Another issue associated with supplying air from the center of the rings is that cold air will seep through the windows. Even though the glass is double-paned it will be colder near the windows.

This diagram demonstrates that during winter months, cold air attempts to seep in through the windows. If a curtain of warm air blows straight up against the window, it will lessen the cold effect drastically.

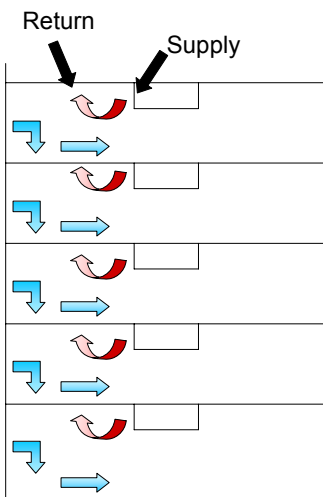
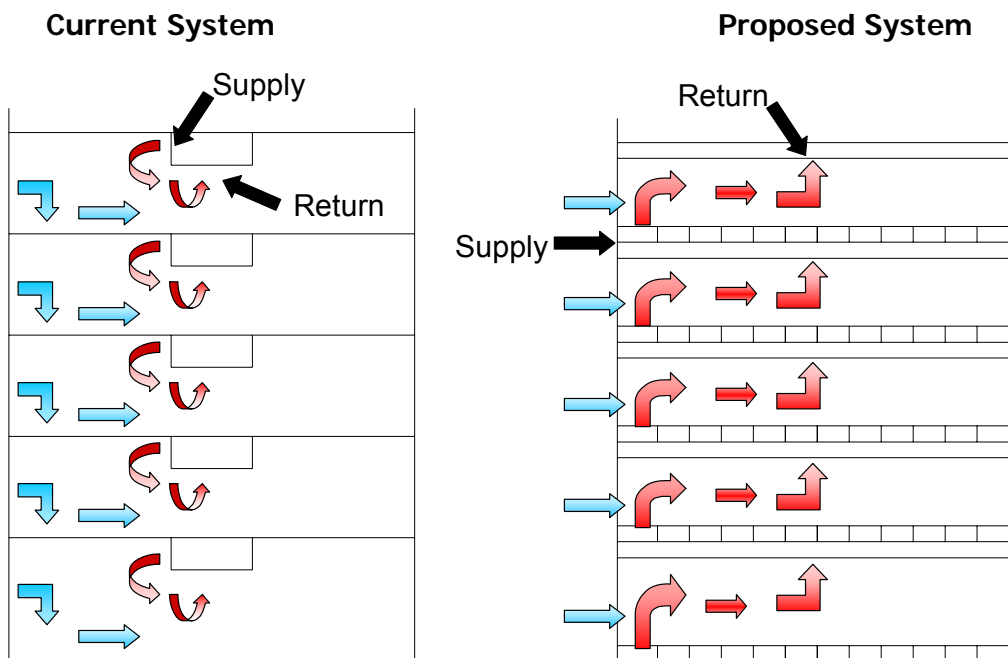

Furthermore, a second system in these areas has a return air plenum in the ceiling near the supply. The diagram to the left shows why this may still be problematic.

This analysis proposes delivering air through the floor, along the exterior walls of the rings. The return air will be returned through grills in the ceiling near the center of the ring. As a case study, we will focus on **Ring C, third floor**.

Pentagon Renovation Wedge 3



Arlington, VA

During summer months, the warm air will also be stopped at the window and mixed with the cool air rising from the floor.

Current System

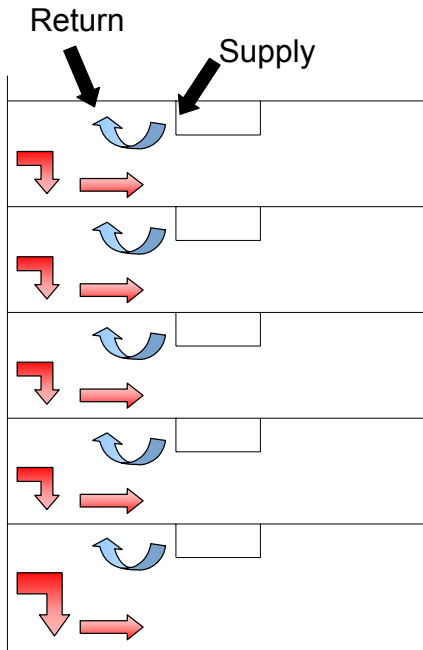

Proposed System

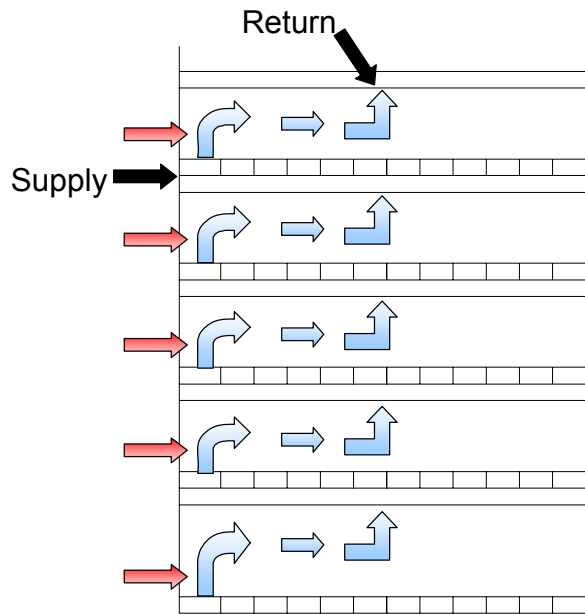

Pentagon Renovation Wedge 3



Arlington, VA

Air Handling Requirements

Wedge 3 has 17 new Air Handling Units supplying approximately one million square feet of habitable space. A typical one delivers about 16,000 cfm, while the largest delivers 25,690 cfm.

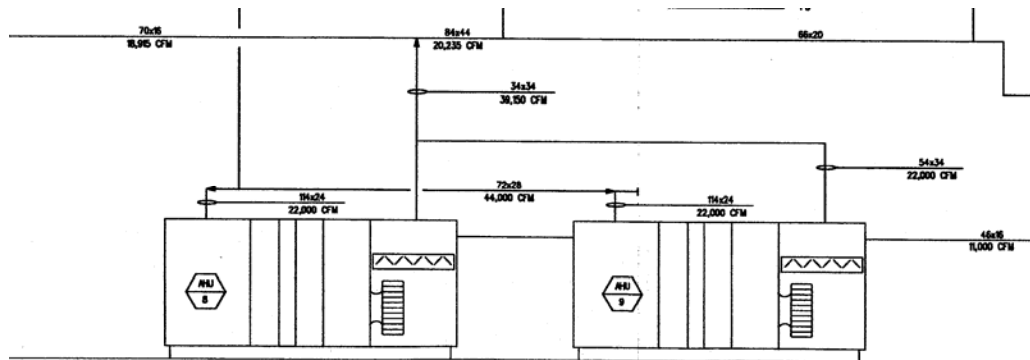

DUCT RISERS FOR "C" RING SERVED BY AHU-8 & 9 IN MECHANICAL ROOM 1C913

AHU 3, AHU 4 and AHU 5 remove a total of 11,993 cfm from Ring C.

These are:

- Ring C – Area 15 : (3) **Returns** of 670 cfm

AHU 8 and AHU 9 supply Ring C with a total of 39,150 cfm.

These are:

- Ring C – Area 15 : **Supply** 4545 cfm
- Ring C – Area 16 : **Supply** 4565 cfm
- Ring C – Area 16 : **Supply** 1400 cfm
- Ring C – Area 15 : (2) **Return** 1820 cfm
- Ring C – Area 16 : (2) **Return** 2345 cfm

Pentagon Renovation Wedge 3



Arlington, VA

The universal space plan is quite efficient in that it uses minimal duct work. A quick summary of the take-offs show that there is a total of 1,830 lf of duct work on third floor, C Ring, of which 410 lf is flexible 10" diameter duct work. A major goal for this analysis is to attempt the new delivery system without using any more duct.

C - 15	
Size	lf
Flex 10Φ	210
10Φ	469
12Φ	135
12x10	15
16x10	20
24x12	6
Total	855

C - 16	
Size	lf
Flex 10Φ	210
6Φ	16
8Φ	22
10Φ	330
12Φ	305
12x10	92
Total	975

Total Wedge 3	1830 lf
----------------------	----------------

Pentagon Renovation Wedge 3



Arlington, VA

Duct Plan

Existing Duct

This is a copy of the HVAC design for a small section of Ring C third floor. It depicts the supply ducts, diffusers and the return ducts for a general office space. It shows flexible duct work that delivers air from the supply ducts to each diffuser.

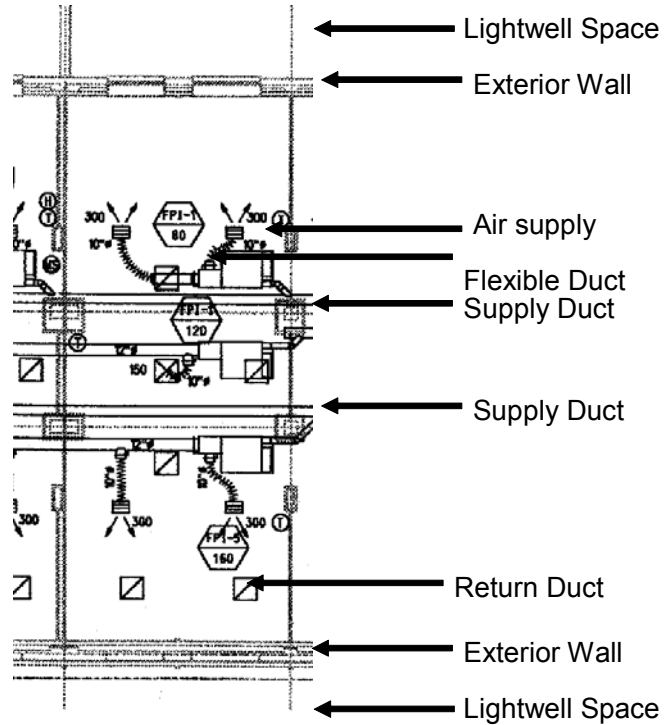

Changes

In the new plan all flexible duct is removed, because the metal duct delivers the air directly to the diffusers under the windows. This saves 410 lf of flexible 10" diameter duct. In these places, there is no additional rectangular duct required either. This figure shows how the flexible duct is eliminated and the rectangular duct is rerouted.

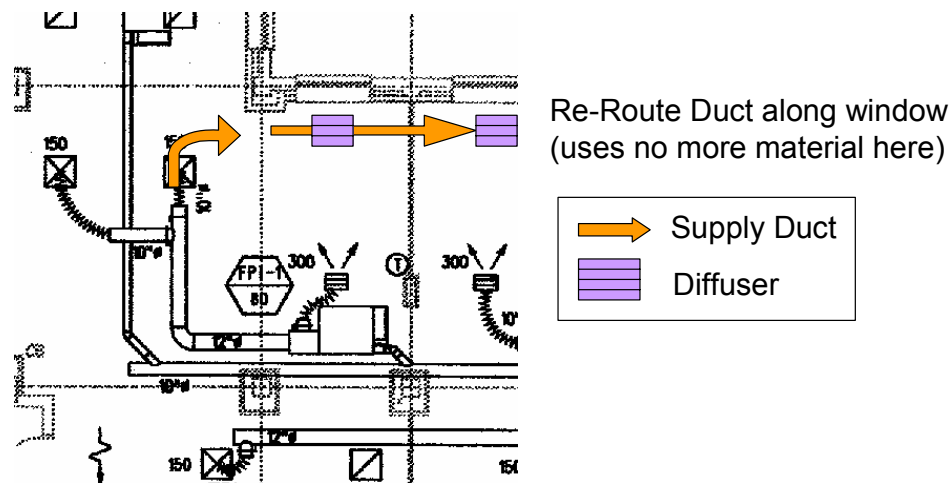

Pentagon Renovation Wedge 3



Arlington, VA

Riser Alterations

The two drawings below show an example of the existing riser diagrams. These will all need to be redesigned so that the return and supply air are in the right place.

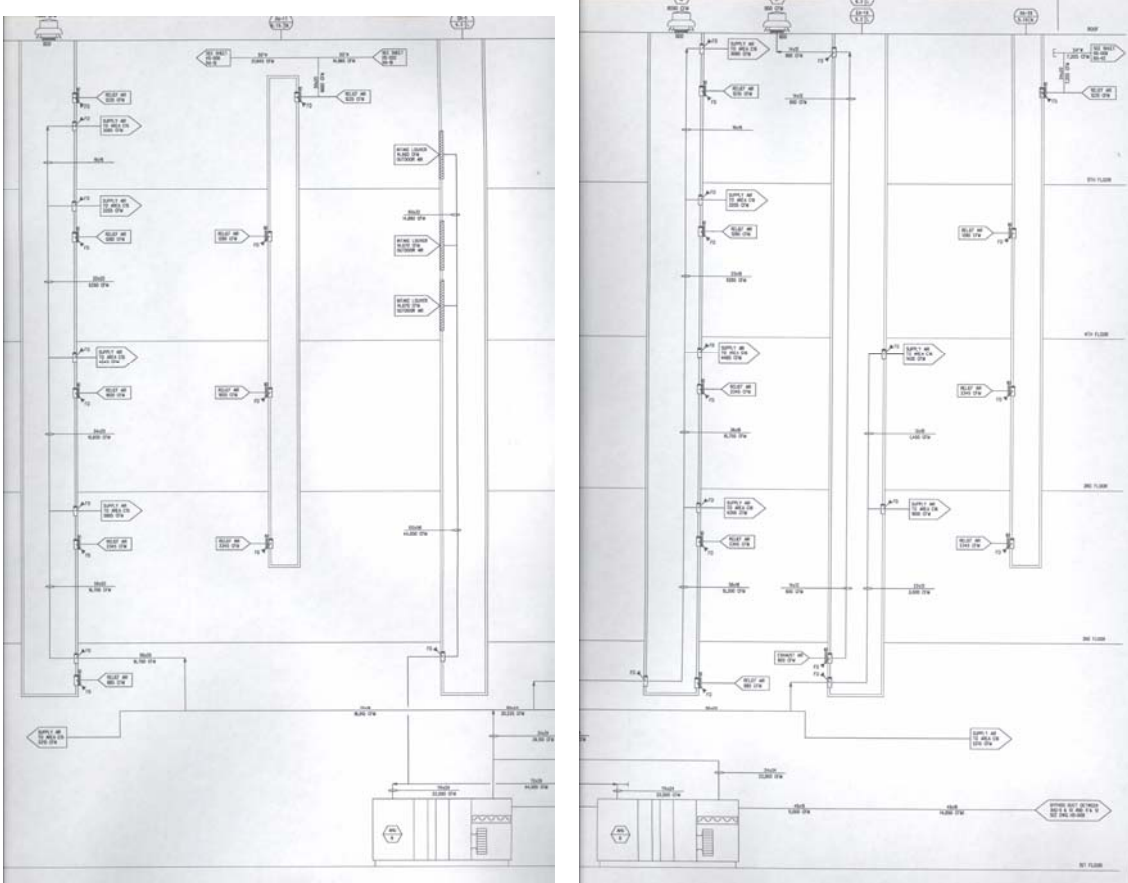

The following two pages show the existing riser diagram for this area and the proposed new one, where the supply vents are in different locations.

Original Riser Diagram

This diagram shows the supply and relief flow in cfm for an existing section of Ring C.

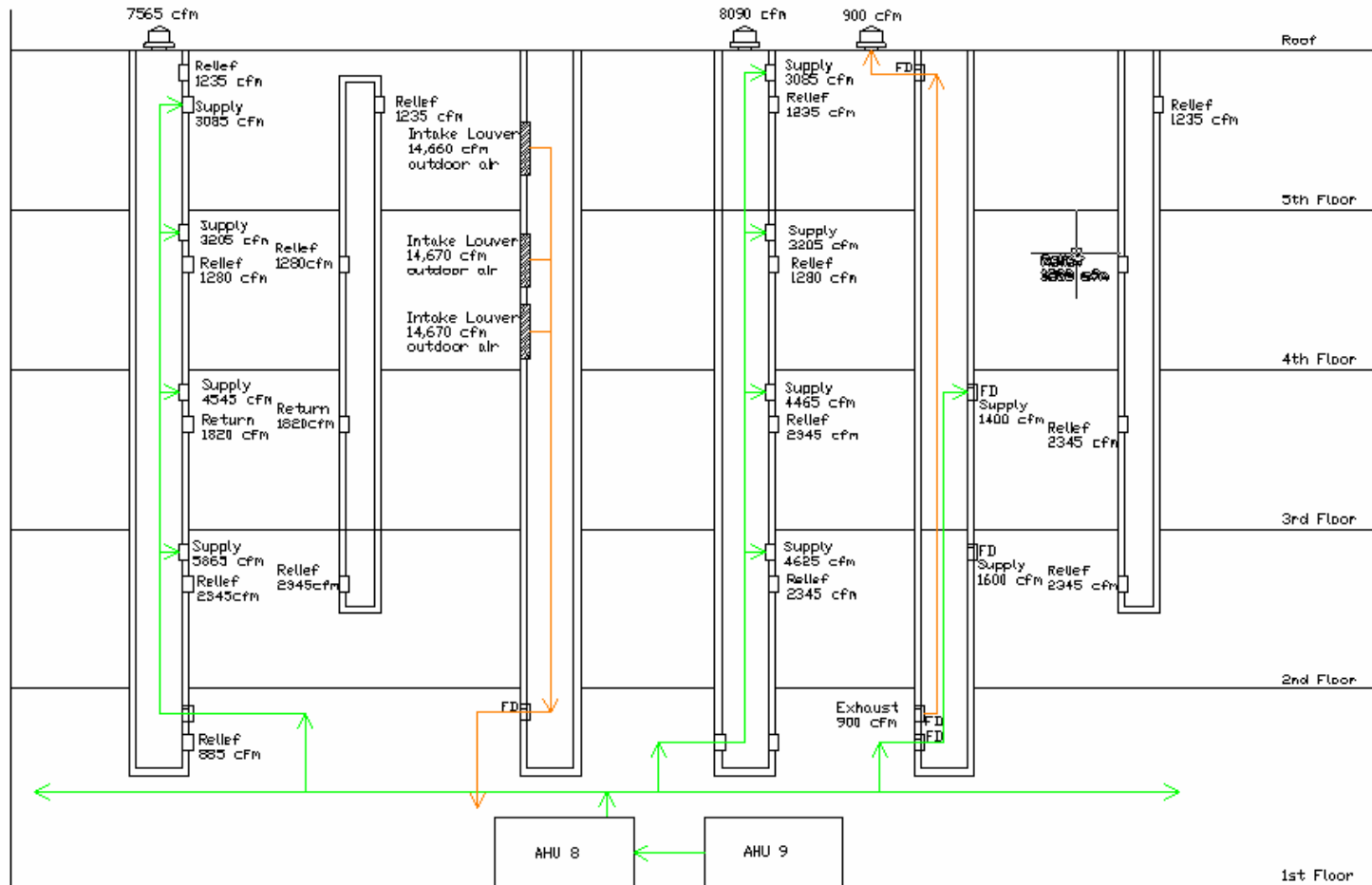

Revised Riser Diagram

This image shows how the supply sections could be cut near the slab floor, rather than near the ceiling. The duct work could then deliver the air underneath the access floor.

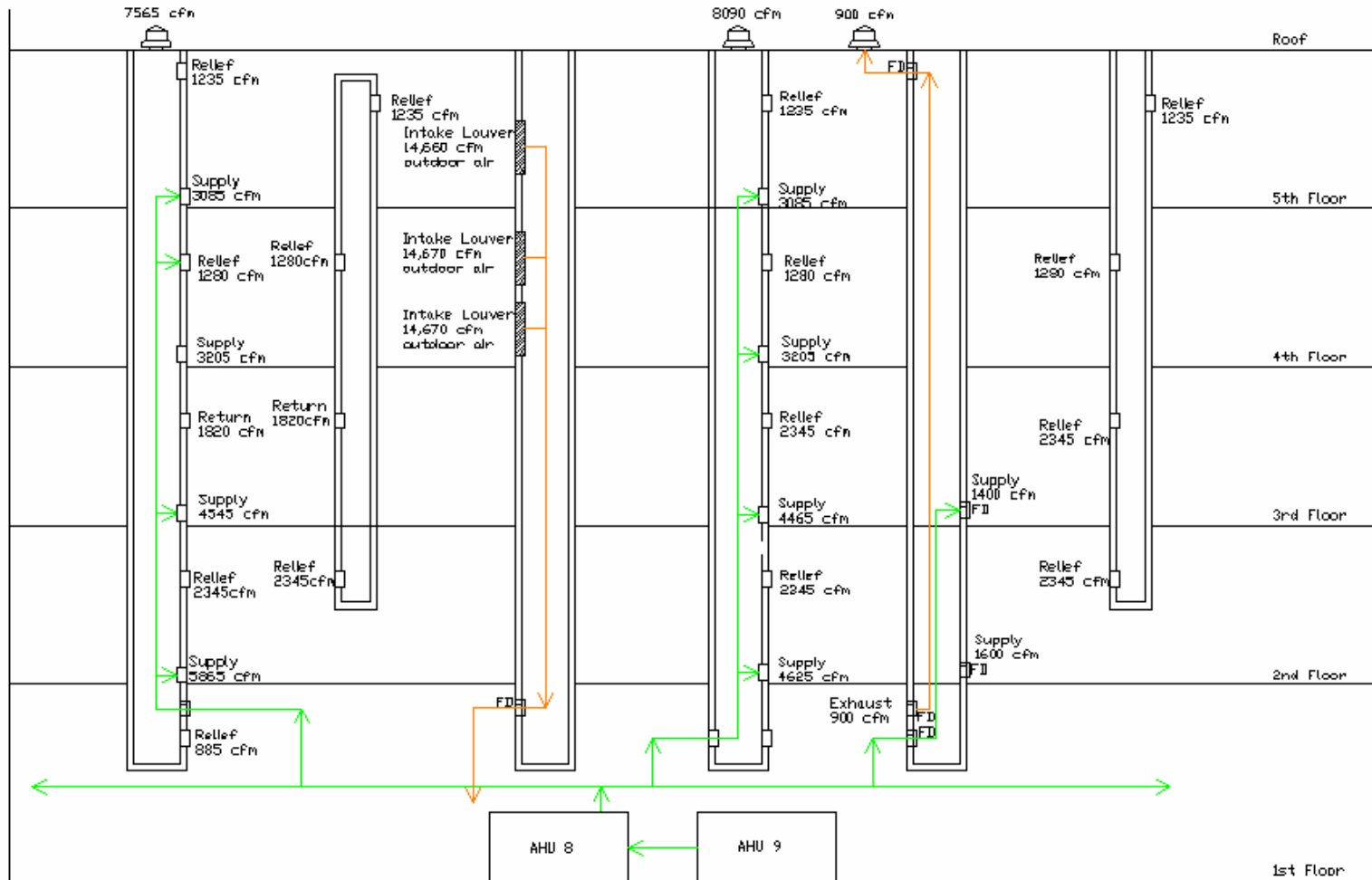

Access Floor Section

This section demonstrates where the major utilities will run through one level of one floor. The supply and return air, the e” fire protection pipes, and the cable trays and conduit are shown.

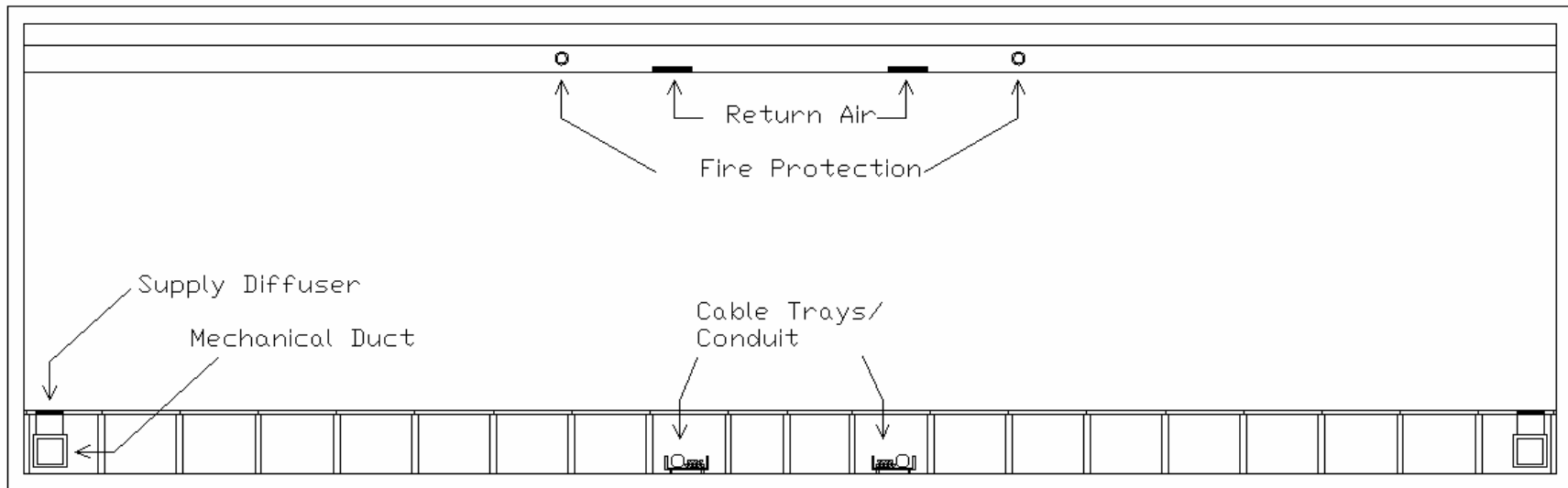

Pentagon Renovation Wedge 3



Arlington, VA

Cost

The use of less duct work has a small cost savings. Removing the 3,960 lf of flexible duct work amounts to a savings of \$5,904.

However, the cost of installing access floor will be much greater than installing carpet. The table below summarizes the cost of installing access flooring.

	Material	Labor	Totals
General Office	\$755,422.50	\$302,169.00	\$1,057,591.50
Computer Room	\$188,857.50	\$75,543.00	\$264,400.50
Control Room	\$126,090.00	\$50,436.00	\$176,526.00
Totals	\$1,070,370.00	\$428,148.00	\$1,498,518.00

Schedule

SIPS Schedule – Existing

The following key and schedule show the existing SIPS (Short Interval Production Schedule).

1	Induction Boxes & Ductwork Fintube Piping	12	Caulking for Wall Close-In JCI Pull Wire Insulate Walls/Vapor Barrier TV Brackets Wall Close-In Inspection	22	Window Blinds Mechanical Diffusers Cut Sprinkler Drops Hang Lights Mechanical PC (Startup) Radian Pull Wire Power, Lighting Term - Demountables	26	Carpet Tile/Base Broadloom Carpet/ Base Fintube Covers QC In-House Inspection (Friday)
2	Sprinkler Mains/Branch Lines	13	Hang Drywall on Walls & Soffits	23	Doors & Hardware Expansion Joints O/H Close-In Inspector JCI Terminate Wire	27	Corrections from In-House Inspection JCI Pre-FPT TAB FPT (Sebasta) Pre-final Inspection
3	Outside Air Branch Duct FPIU Piping Mains	14	Tape & Finish Walls & Soffits Install Access Panels	24	Install Ceiling Tile Fire Protection Trim Electrical Trim HVAC Trim JCI Final Trim JCI PC (Startup)	28	Corrections from Pre-Final Inspection JCI FPT (Sebasta) HP Final Walk (Friday)
4	FPIU Piping Connections and Test	15	Prime & Paint Walls & Ceilings	25	Point-up Final Paint Final Clean Install Security Devices & Test Mechanical Punchlist JCI Punchlist Test & Balance (Night Work) Subcontractor Self Inspect & Correction	29	Furniture Photo-luminescence Install Desk Top Door Release Button
5	Mechanical Pipe/Duct Insulation	16	Install Smart Walls & Wire Mold	30	SIPS Compete (Monday)		
6	Frame A-Zone Bulkheads Frame/Drywall B-Zone Bulkheads	17	Install Smart Walls & Wire Mold Install Wire Mold 5500				
7	Frame Nibs & Columns	18	Demountable Walls				
8	Frame Nibs & Columns Frame A-Zone & Exterior Walls Caulk B-Zone Bulkheads	19	Pull Comm & Data Wire - IM&T				
9	PDS Cable Conduit & Tray	20	Smart Wall Wire / IM&T Term & Trim Caulking Above Ceiling				
10	O/H Electrical & Wall Rough-In BDS Backing	21	Install Ceiling Grid Window Trim Fintube Cover Clips				
11	Pull Power Wire Rough-In Inspections - Walls TV Brackets BDS Backing						

SIPS Schedule – Revised

To successfully install the access floor, first the pedestals on which the panels rest are laid out, then bolted into the concrete slab. After all the underneath utilities are installed, such as mechanical duct, cable trays and conduit, the floor panels may be installed.

For this process to fit into one SIPS block, the entire process must take up to one week per zone to install. It is a generous assumption to give a full day for the following tasks: One day is required to lay out the grid for the support pedestals, one day to place the pedestals, one day to bolt them into the concrete, and two days to install the panels. Therefore, this fits easily into a five day week. However, after the first three days, a five day slot will be used to install conduit and cable trays. Then the panels will be installed. This results in an additional week at week nine of the SIPS schedule.

Task	Week 1					Week 2				
	Mon	Tue	Wed	Thurs	Fri	Mon	Tue	Wed	Thurs	Fri
Layout a grid of 2'x2' for pedestals										
Place pedestals onto 2'x2' grid										
Bolt pedestals into concrete										
Install cable tray										
Pull conduits										
Install access panels										

The new key is shown below.

1	Induction Boxes & Ductwork Fintube Piping	10	O/H Electrical & Wall Rough-In BDS Backing	19	Pull Comm & Data Wire - IM&T	25	Point-up Final Paint
2	Sprinkler Mains/Branch Lines	11	Pull Power Wire Rough-In Inspections - Walls	20	Smart Wall Wire / IM&T Term & Trim Caulking Above Ceiling		Final Clean Install Security Devices & Test Mechanical Punchlist
3	Outside Air Branch Duct FPIU Piping Mains		TV Brackets BDS Backing	21	Install Ceiling Grid Window Trim Fintube Cover Clips		JCI Punchlist Test & Balance (Night Work) Subcontractor Self Inspect & Correction
4	FPIU Piping Connections and Test	12	Caulking for Wall Close-In JCI Pull Wire	22	Window Blinds Mechanical Diffusers Cut Sprinkler Drops Hang Lights Mechanical PC (Startup) Radian Pull Wire	26	Carpet Tile/Base Broadloom Carpet/ Base Fintube Covers QC In-House Inspection (Friday)
5	Mechanical Pipe/Duct Insulation		Insulate Walls/Vapor Barrier TV Brackets Wall Close-In Inspection		Power, Lighting Term - Demountables	27	Corrections from In-House Inspection JCI Pre-FPT TAB FPT (Sebasta) Pre-final Inspection
6	Frame A-Zone Bulkheads Frame/Drywall B-Zone Bulkheads	13	Hang Drywall on Walls & Soffits	23	Doors & Hardware Expansion Joints O/H Close-In Inspector JCI Terminate Wire	28	Corrections from Pre-Final Inspection JCI FPT (Sebasta) HP Final Walk (Friday)
7	Frame Nibs & Columns	14	Tape & Finish Walls & Soffits Install Access Panels		Install Ceiling Tile Fire Protection Trim Electrical Trim HVAC Trim JCI Final Trim JCI PC (Startup)	29	Furniture Photo-luminescence Install Desk Top Door Release Button
8	Frame Nibs & Columns Frame A-Zone & Exterior Walls Caulk B-Zone Bulkheads	15	Prime & Paint Walls & Ceilings			30	SIPS Complete (Monday)
◆	Install Access Floor Stringers PDS Cable Conduit & Tray Place Access Floor Panels	16	Install Smart Walls & Wire Mold	24			
9		17	Install Smart Walls & Wire Mold Install Wire Mold 5500				



Conclusions

Access floor makes a lot of sense in these office regions. It will be easy to maintain all mechanical and electrical systems. Also, it will keep the plumbing away from the mechanical systems, preventing some trade clashing.

The major benefit is the improved air circulation which will improve the comfort level for the tenants. The new system also seems more efficient. In Ring C third floor alone, 410 linear feet of duct was saved, and a total of 3,690 lf throughout the designed spaces.

The space under the raised floor may hold all the electrical power in cable trays, data and telecommunications wires, environmental control and air conditioning and mechanical supply ducts. This will improve the construction speed and ease future tenant space changes.

However, the cost of installing an access floor is much greater than standard commercial carpet. For about one million extra dollars, the improved circulation and ease for future maintenance and expansion of the under floor utilities should be worth this cost. It is important to note that the SIPS schedule will be extended by one extra week's length for the installation of the floor, but the overall project schedule will not be affected.



Demolition

Background	3.2
Problem Statement.....	3.3
Proposal	3.3
Existing Situation	3.3
New Plan	3.7
Costs	3.10
Conclusion.....	3.10



Demolition

Background

Demolition began June 15, 2005 and was to be completed by September 2005. For the renovation of Wedge 1 and Wedge 2, as well as currently for Wedge 3, there has been a trash chute utilized to aid in the removal of demolished waste from the building. This trash chute runs the height of the entire five stories of the building on the outer E-ring. The exterior wall is limestone panels on E-ring, and therefore the stone facade must be removed, by a tedious process of the mortar being chiseled away and the stone hoisted off by crane. For Wedge 3, the trash chute is located near corridor seven. Several dozens tons of debris may be removed in one day during demolition, with the assistance of bobcats and buggies indoors.

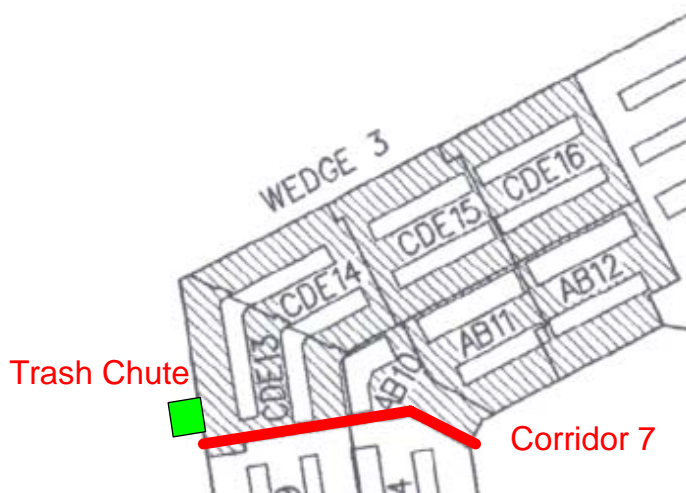

During full swing demo, there was be 300 employees for LVI and their subcontractors working on demolition, abatement and the removal of these products.



Problem Statement

Historically, some of the heavy limestone panels are damaged when they are removed from the building, whether they are chipped or broken entirely. When the stone is placed back, it is nearly impossible to match the mortar color exactly to the existing, which is problematic for the architects and contractors because of their expectations of quality on the exterior of the Pentagon. The mismatched mortar is quite visible on Wedge 1, and even slightly so on the Wedge 2 trash chutes. An example of the difficulty in matching colors is shown below, where one sees the mortar at the corners of a limestone column that do not reflect the same tone as the rest of the stone. This work needed to be replaced.



Proposal

As a solution, I will coordinate an alternative way to remove the entirety of the debris from Wedge 3 without the necessity of an exterior trash chute. This will begin with a brief description of the existing plan.

Existing Situation

The following page details a drawing of the current trash removal program. Wedge 3 is shown with the stairs at the end of corridor 7 labeled. The trash chute (#5) is at the end of corridor 7. A ramp going down the stairs of the terrace entrance (#4) assists in the removal of wheeled carts with debris as well.

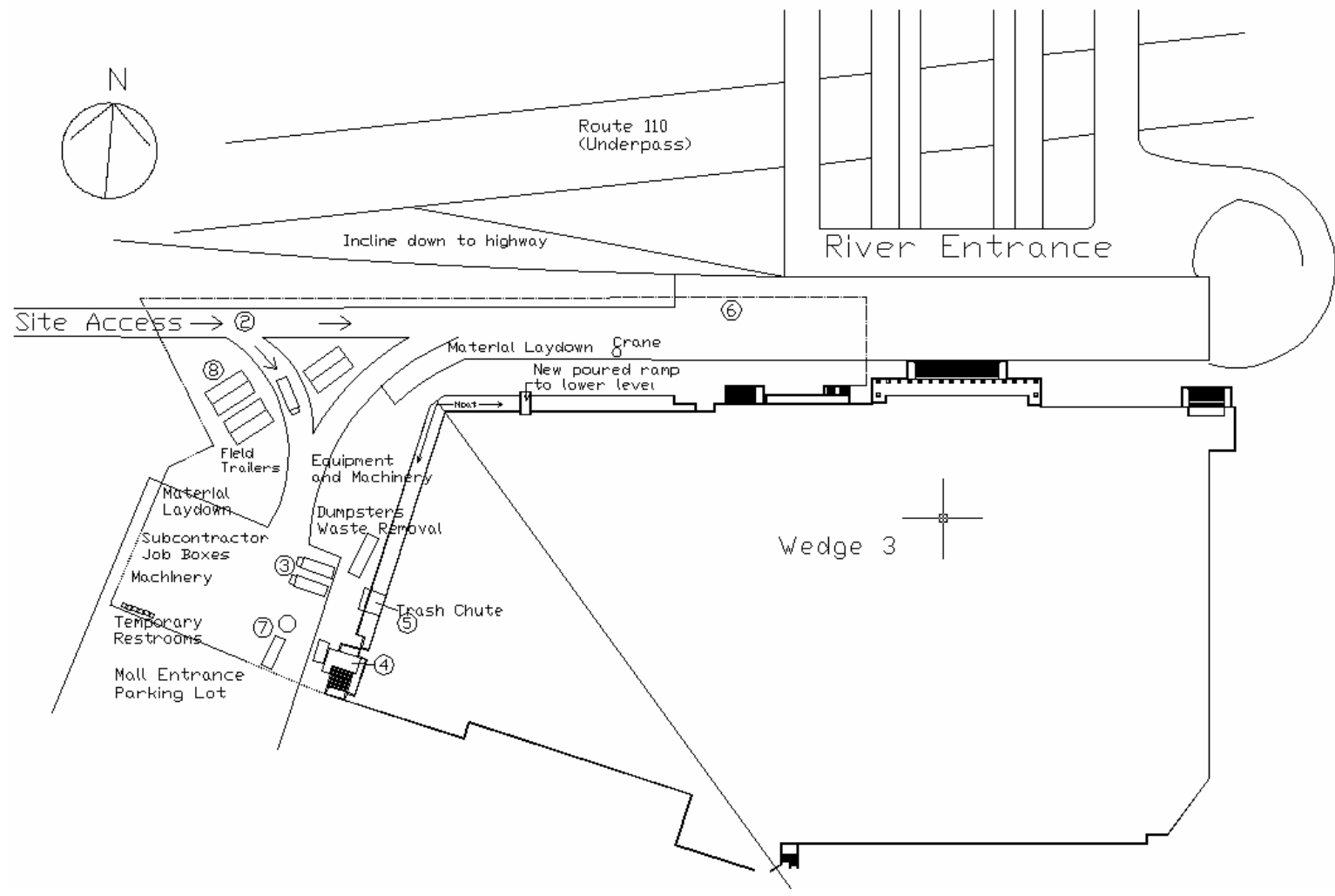



Utility Risers

The scope of Wedge 3 involves several new utility risers, many of which are located along the main radial corridors 7 and 8. These penetrations are cut during the demolition process. If these penetrations are used to lower trash from the upper levels to the ground level, the debris may be removed from the entrance at corridor 7. This means that no limestone masonry shall be removed from the façade.

Also, there are several existing penetrations that are scheduled to be infilled after the demolition process is complete. One such slab that is the most conveniently located exists between column line 7.22 and 7.23. It is directly near the mall terrace entrance which will serve as the exit route for the trash. From level 2 through 5, there is a 9' by 7' square. The details describe that it is to be eventually filled with a metal deck and a concrete slab. However, during demolition this shaft could serve as the main trash chute, for it is equivalent in size to the one that was on the exterior façade of the building.

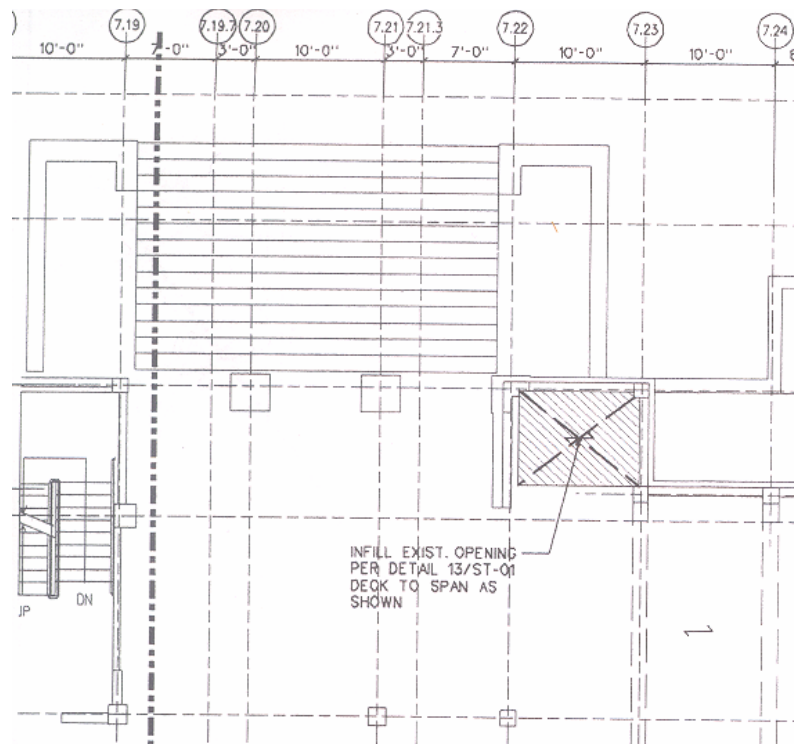

Pentagon Renovation Wedge 3



Arlington, VA

Another existing penetration that will be filled exists along corridor 8. It is a 10' by 7' space and rises from the ground ceiling to the fifth floor, making it another ideal location for an interior trash chute.

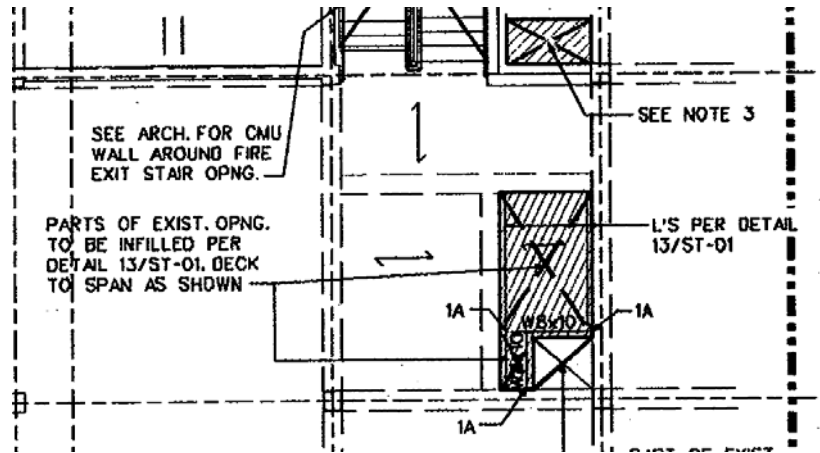

These pictures below show a shaft along ring C where it meets the corridor. This shaft is a trapezoid of the approximate dimensions 6' by 10', and was cut during the demolition phase of Wedge 3 in June 2005. This is another example of a space large enough for an interior trash chute to be installed.





New Plan

The new demolition plan will use all interior penetrations as trash chutes. All debris will exit the building via the main terrace entrance where the historic steps exist. These steps are already covered with a ramp and temporary loading dock which will make emptying debris into larger dumpsters easy.

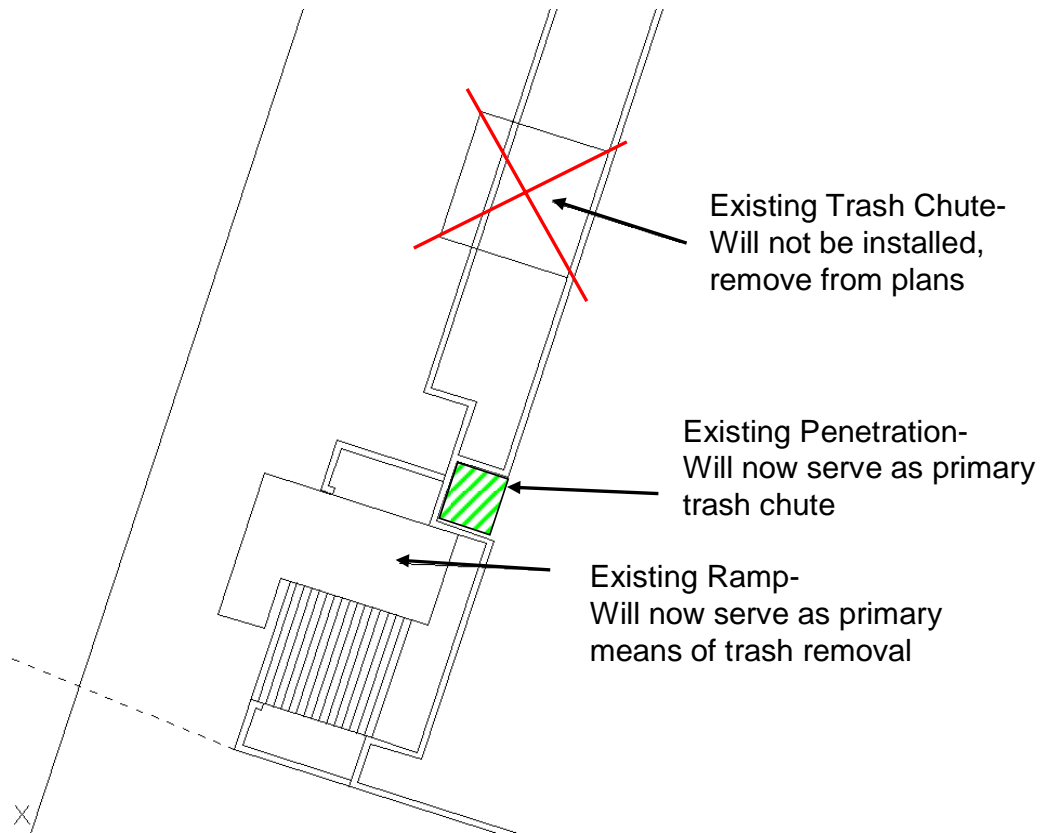

All the following shafts, both existing before construction and some that are new cut penetrations shall be used. The location of each is shown on the following page.

Location		Size
<i>Existing Penetrations</i>		
1	Terrace Entrance E-Ring	
2	A-Ring Corridor 8	13' x 8'
3	A-Ring	13' x 9'
4	D-Ring Corridor 8	10' x 7'
5	E-Ring	8' x 8'
<i>New Penetrations</i>		
6	C-Ring Shaft	10' x 9'
7	B-Ring Shaft	10' x 8'

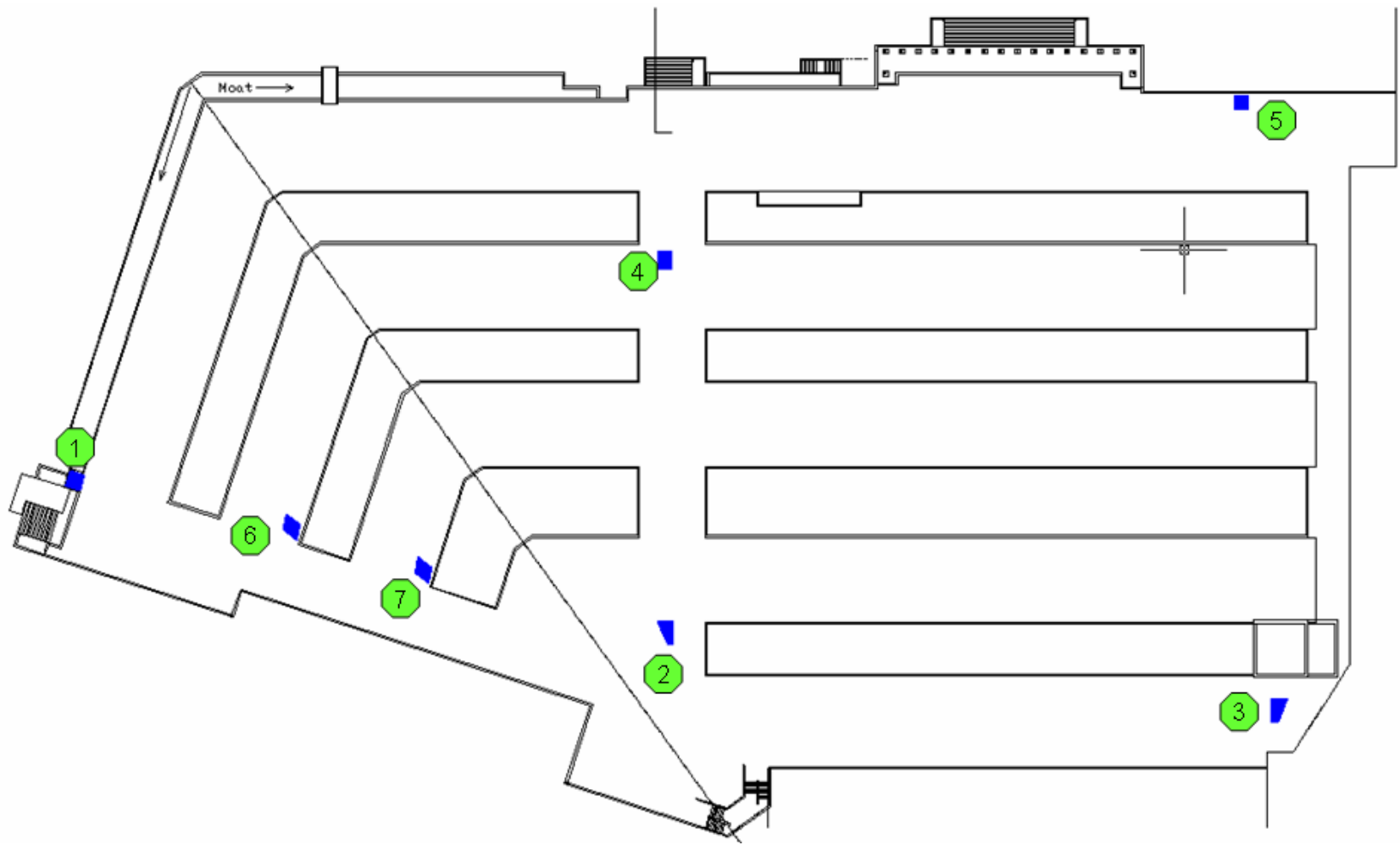

Pentagon Renovation Wedge 3



Arlington, VA

Under the new proposition, the same bobcats will still be used. However they will deliver demolished material to the interior trash chutes.



Part of the new plan is also to show what regions will use which trash chute. Below is a color coded scheme showing the flow of debris.

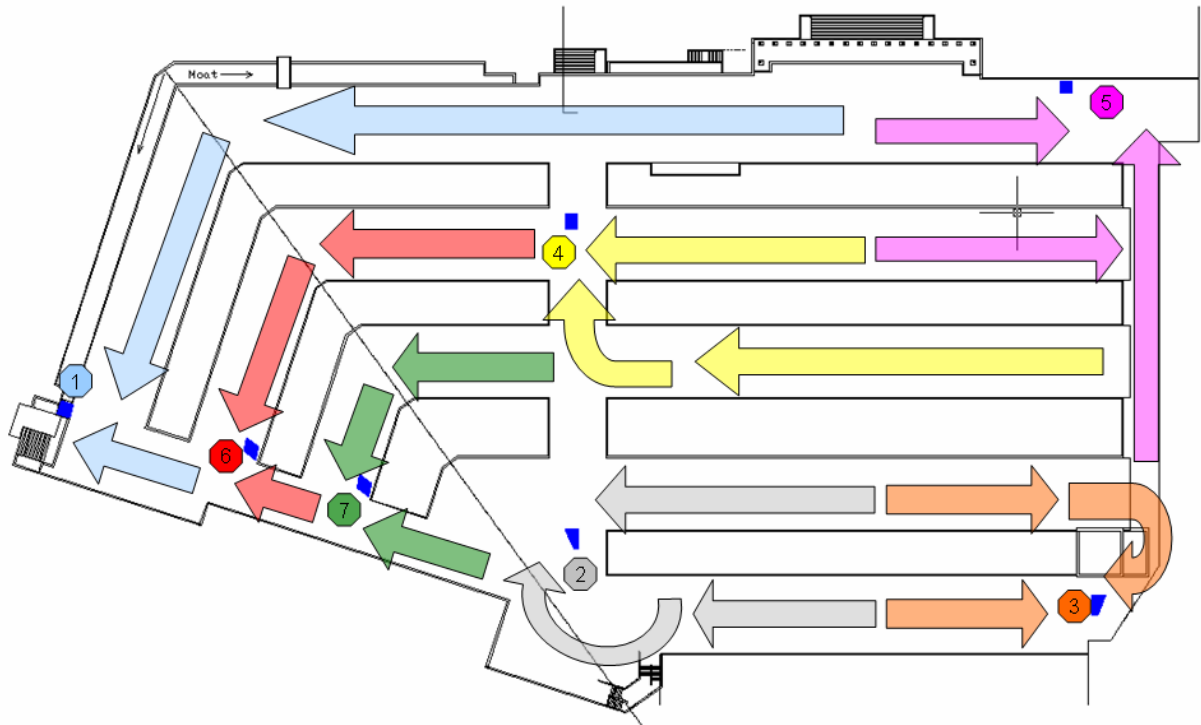



Costs

There are already sufficient funds for dumpster rental in the general conditions segment of the budget. To implement interior trash chutes will not affect the amount of dumpsters or rolling carts needed. However, there will be many smaller rolling dumpsters used because due to the inside process. An example of these smaller containers is this 2 cubic yard capacity container. It is 5' long x 3.5' wide x 4' deep and is rented for \$80 per month.



The larger 10 cubic yard capacity rolling dumpsters are 12' long by 6.5' wide x 4' deep and cost \$140 per month to rent.

Conclusions

It does not affect the construction process to use the interior penetrations rather than the exterior trash chute. It also prevents the problem of removing the exterior façade and having to replace it, which has proven to be unsuccessful. Therefore, this plan is successful and could be implemented.



Dynamic and Large Project Teams Research

<i>Introduction</i>	4.2
<i>Team Development</i>	4.4
<i>Team Dynamics</i>	4.6
<i>When Problems Arise</i>	4.6
<i>Large Project Teams</i>	4.6
<i>Case Study – The Pentagon</i>	4.8
<i>Problem 1 – Document Control</i>	4.9



Dynamic and Large Project Teams – Dealing With Less Than Ideal Project Situations

Introduction

It has been researched that most teams fall into the category of two to twenty-five members. The groups that are considered the most manageable and efficient are groups involving five to nine people. When a project is so large that there are many more people involved, there are several potential problems. With teams of people over nine members, often conversation becomes centralized. No one person gets across their opinions effectively, simply from the lack of time and confusion from the numbers.

Another odd phenomenon with large groups of people is that each person's productivity decreases when they work with increasingly large numbers of people on any

one assignment. In any case where the productivity of a team can be measured numerically, it is related directly to the number of people working in the team. These two charts aid in visualizing this phenomenon.

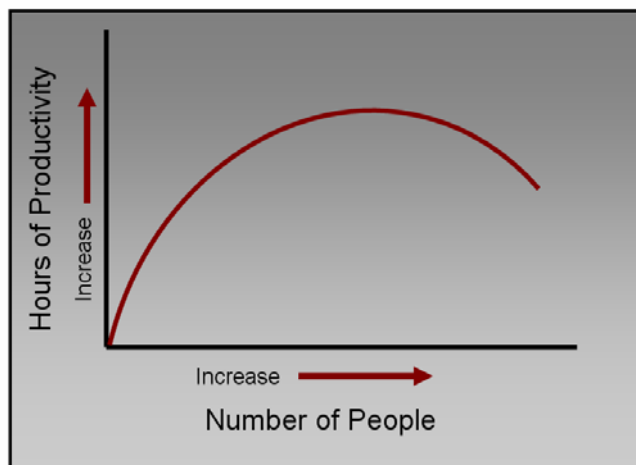
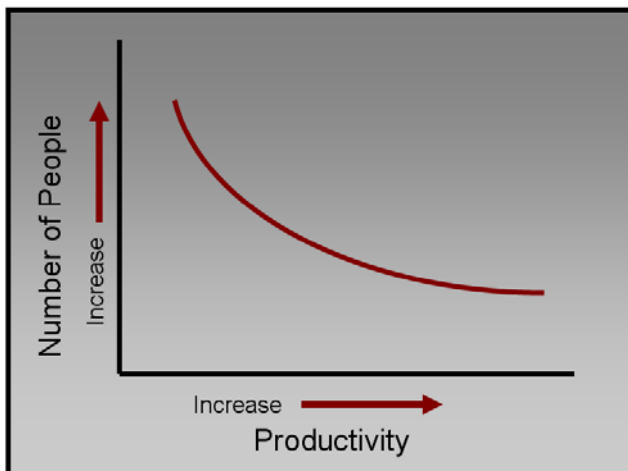

It is important to have a team filled with individuals with the appropriate skills necessary for the proper and efficient completion of the project. When there needs to be a staff of several dozen people, these skills tend to become more specialized. As an example, I will discuss the project teams for two separate projects.

Pentagon Renovation Wedge 3



Arlington, VA

Project 1

Project: Renovation and addition to the Recreation Hall on the Penn State Campus

Cost: Approximately \$11 million

General Contractor: Gilbane

Gilbane Project Team: 1 project manager, 1 superintendent, 1 intern

Project 2

Project: Renovation of Wedge 3 at the Pentagon in Arlington, VA

Cost: Approximately \$370 million

General Contractor: Hensel Phelps

HP Project Team: About five dozen employees

This diagram shows only the management at the Pentagon Wedge 3 Project

Staffing Plan - Management

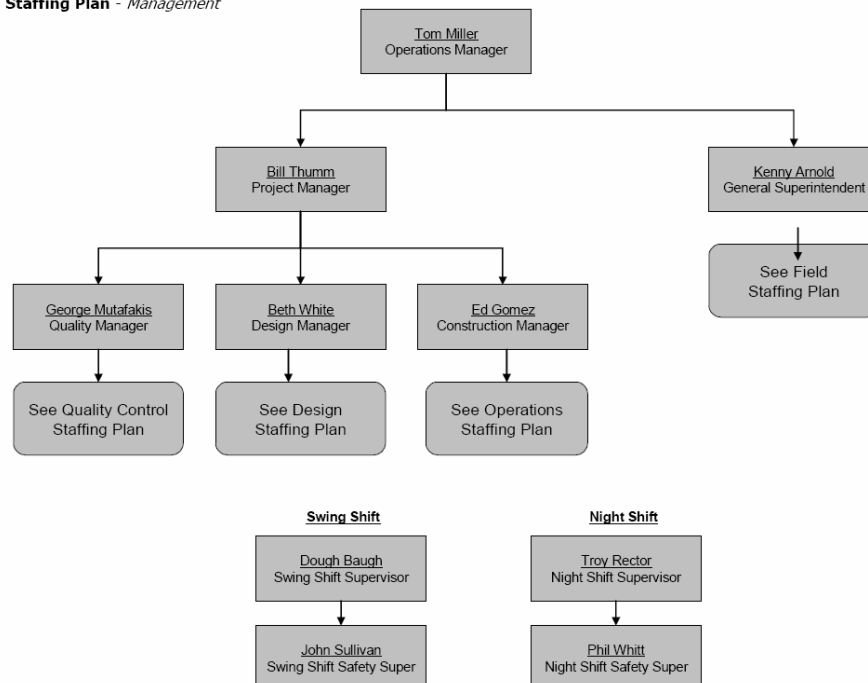



These two scenarios demonstrate the vast difference between smaller construction projects and larger ones. The members of this first team are responsible for all project management, as well as recording daily onsite work, communicating with subcontractors, and tracking their own paper work. The second project is a strong example of specialized work, where there are entire departments of people working on specific tasks such as Document Control, Quality Control, Office Engineering tasks, Field Engineering Tasks, and more.

Both teams, whether of three individuals or fifty have the same responsibilities. These individual responsibilities include:

- Carrying out all tasks which are assigned
- Providing administrative support
- Assist managers in achieving all team objectives and goals
- Advising managers in risky situations or crises
- Provide all required documentation and information
- Maintain organized and efficient work environment

Team Development

A major concern when dealing with larger teams arises in the development of the team. A survey of industry members resulted in a better understanding of some of the major concerns when developing unusually large project teams:

- How will many individuals function together?
- Will there be personal interactions affecting the team goals?
- Will the level of professionalism remain high?
- How can several people remain a cohesive and functioning team throughout the entirety of the project?



After interviewing several industry members, there were some conclusions drawn about selecting members for project teams, and dealing with the diversities of people:

When developing project teams during the preconstruction phase, project managers make several decisions regarding their management and staff positions. A summary of their responses for strong team member selection follows:

When selecting employees for management positions in a project team:

- Select those who focus on establishing customer relationships
- Individuals with a vision of the finished project
- Those with goal setting, negotiation and problem solving skills
- Ones who have demonstrated leadership and team development skills

When selecting employees for staff positions, to work under upper management, the idea criteria these managers look for in their personnel includes:

- Those with technical proficiency in all necessary disciplines
- Wide variety of experiences
- Amount of previous experience of similar successful projects
- Individuals who demonstrate willingness to teach subordinates to grow in knowledge and responsibility

Two very important points mentioned over and over by industry leaders suggest finding people for all levels of a project team with high levels of self confidence in their abilities, as well as a desire to grown and learn in new areas.



Team dynamics

When dealing with teams of various sizes, it is important for managers to promote learning and development for individuals for their future growth in responsibility. This involves continual reinforcement to all members of the importance of the finish product, as well as reminders of the customers' confidence in each member and their expectations of quality for the product for which they are paying. The manager of Industrial Resources, Inc. in Pittsburgh advises to "... try to establish open customer relations at each level of responsibility. We try to team-up with our customer's team at each level, while reporting communications up the ladder." A strong manager will inform their team of all major issues regarding the budget and schedules, as well as involving them by asking for suggestions to solve problems.

Perhaps the most crucial thing for a team to do initially is to develop goals. Having a common purpose is the reason for creating teams, but generating concern about the purpose from each member is crucial with large numbers.

When Problems Arise

It commonly occurs that a less than ideal project team is created, often because of the lack of staff availability. There are several steps that should be taken by managers to alleviate any friction between members of a team. Friction occurs most often when a new member is introduced into a team, or at the upstart of a project, when members are familiarizing themselves with the practices and personal behaviors of the people they work with.

As stated by one manager, "Friction (in the work place) comes from someone thinking that the other guy isn't doing his job or share of the work." This manager recommends focusing on the successful project outcome as the reason for teaching and learning. By explaining the expectations to both the teacher and the learner in a one-on-one setting, there is an opportunity for a face to face discussion which should remind members of the importance of having mutual respect for all parties involved in the



project. Each team member should report to a manager if they are not receiving this respect.

Managers may make all team members feel this respect by announcing an open door policy for resolution of any problems they occur, while continually reminding them that a successful project is the outcome in the balance. Managers must also infer that unproductive friction won't be tolerated, as it puts the entire company's reputation and success at risk.

Suggestions for alleviating issues between team members:

1. Consider each day a team development exercise in real time.
2. Be communicative to all members about problems they are creating. Private meetings with members will remind them of their responsibilities privately.
3. Remember that "trouble makers", or those who are difficult to work with have probably heard this before from a previous manager and are aware that they need to correct their behavior. Reinforcement of this will remind them to redevelop personal goals.
4. Remind any members involved in conflict that the successful outcome should be their vision, goal, and obligation to the company, and that the company can not tolerate behavior disruptive to the common goal.

Some common responses of failed methods of dealing with team members:

1. "I don't believe off-site seminars are effective by themselves. People who are sent to these feel singled-out as bad apples, and may become more defensive and build more excuses around their private fortress."
2. Do not embarrass trouble makers by reprimanding them in front of others. Private discussions will not make them feel alienated from the team.

Team members, especially in larger groups, tend to work too independently on problems. Often times this occurs in the more senior people of a company, where upper



managers try to do all the problem solving themselves. To create a more cohesive team, close supervision by all team members of each other's progress is recommended to identify this tendency. Once identified, the solution is often simple and involves proper communication of the problem. Though it is often difficult to approach senior team members with advice, the stalled problem solver often welcomes this approach. It reminds them that their team is indeed capable of more responsibility and that they are present to continually reinforce the managers decisions with their own personal problem solving skills.

All members should schedule personal brain-storming sessions of self-evaluation. Often these personal "time-outs" offer some new directions to explore for developing solutions.

Research Focus – Large Teams

Case Study – The Pentagon

Now that some issues such as personal dynamics and problem solving strategies have been discussed, the focus of this research points to unusually large project teams. The general contractor Hensel Phelps employs a team at the Pentagon Renovation project of several dozen people.

Communication is important, but often is disrupted when passing information along such a long chain of people. Everyone needs to collaborate with each other, the customer, and the subcontractors.

The following challenges are real challenges that occur at the Pentagon project. After the problems are discussed and analyzed, there will be some proposed solutions to reduce the problems.

Pentagon Renovation Wedge 3



Arlington, VA

Typical Pentagon Challenge – Document Control

At the Pentagon, the overlapping matrix teams serve multiple functions to one another. By inspection of the Operations Team, one notes the major operations managers in green, the office staff highlighted by blue, the secretarial staff in purple, and the document control staff in red. Each of these teams has its own designated manager or leader. Take note that the document control team has five members to its single team.

Staffing Plan - Operations

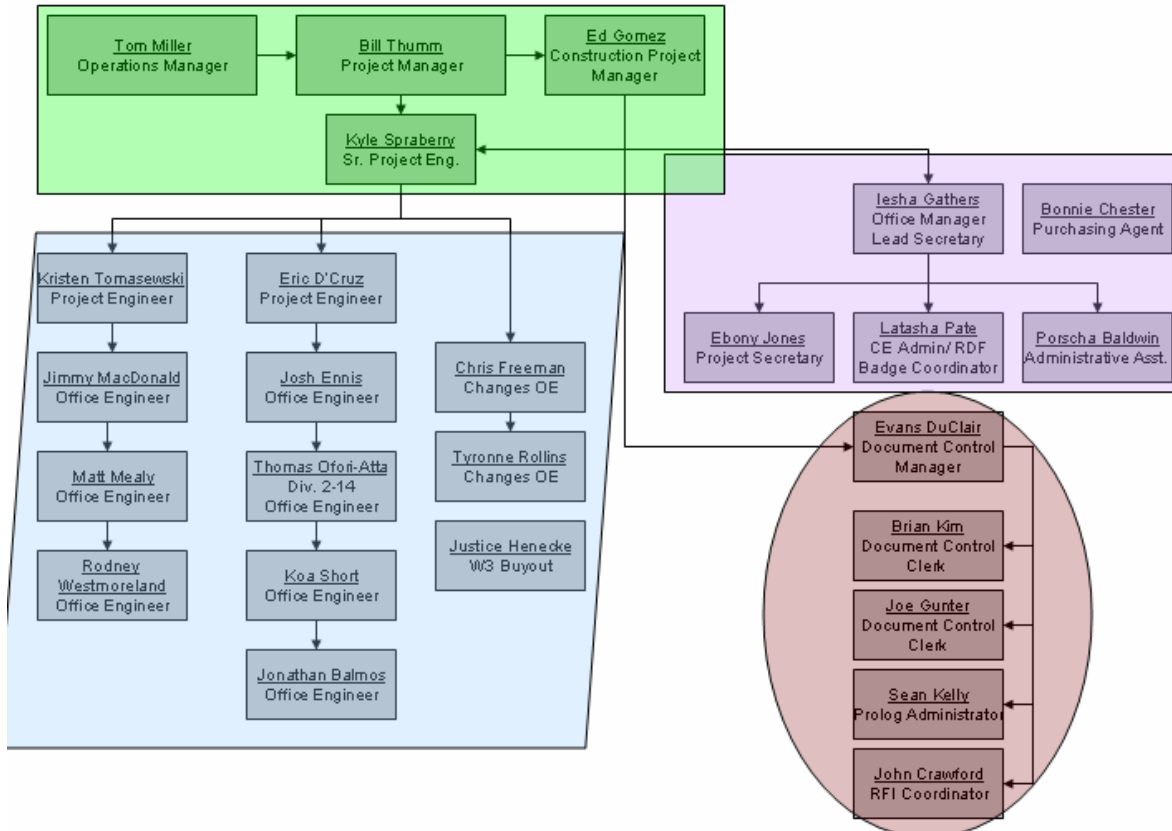

A major problem with so many people working on such a large project arises with the document control. This team is responsible for continually updating and maintaining copies of the plans and specification sheets for Wedge 3. They are separate from the office team. A task of the office team is sending the proper drawings to the



subcontractors under their responsibility. It is a common occurrence for a subcontractor to receive drawings from an office engineer, while another updated set of drawings exists in document control. However, there is no record of which drawings are mailed to subcontractors and at what time, and it is difficult for an office engineer to track the changes made by document control. This has led to subcontractors having incomplete or entirely incorrect plans on multiple occasions. The documents change throughout construction as it is a design build delivery, as well as the fact that tenants of the building make design changes rather often, causing change orders and redesigned interior spaces.

Proposed Solution

Going digital is a major advantage for any sized project, however I see the benefit of being more digital as exponentially higher for a scenario such as this. All employees of Hensel Phelps and PenRen at the Pentagon have access to a shared intranet for information sharing. However, the project plans are kept on paper copies in a control center near the job site. At this center, the document control manager has access to the digital plans, but the others in the office do not. Sharing these plans over the intranet, for members of the contractors team would not only minimize this chance for office employees to send obsolete drawings, it would also greatly increase efficiency in sending drawings.

Document control exists as a way to maintain who is receiving this confidential plans and specifications. I believe that if electronic plans were available, it would be more difficult to track who was viewing and sending them, which could become problematic for PenRen. Therefore, I believe that there could exist a special access password so that only those who had absolute necessity for the digital plans could have access to them. This alleviates any problems with people attaining documents without authorization, and allows document control to know which people have access to the plans.

Setting this up digitally will increase efficiency and eliminate the chance for subcontractors to receive outdated drawing versions, since they are continually changed

Pentagon Renovation Wedge 3



Arlington, VA

during design. Also, there would be a huge savings from printing much less paper copies. With a \$50,000 a month office supplies and printing expense, these costs add up much faster than many realize.

The Pennsylvania State University Architectural Engineering Senior Thesis

Personal Acknowledgements

A special thanks to:

Penn State Advisor

Dr. David Riley

Hensel Phelps

Tom Miller—Project Manager

Eric D’Cruz—Project Executive

David Allen—MEP Quality Control Inspector

Sara Michalski—Wedge 2/Wedge 3 Intern

Architectural Engineering Peers

Gregory Eckel—Structural Option

Anthony Lucostic—Construction Management Option

Brian Quinn—Construction Management Option

Industry Professionals

J. Boyd Rankin, P.E.

Michael Greco

Christopher Knestaut

This years work dedicated in Loving Memory to
Josephine Oprosky
1931-2006