

Mountain Hotel, Urban Virginia

Ben Borden

Structural Option

December 14, 2012

Kevin Parfitt



Table of Contents

Title Page	1
Table of Contents	2
Executive Summary	3
Building Introduction	4
Structural Overview	5
Code Requirements	6
Gravity System Overview	7
Superstructure	7
Substructure	7
Floor Systems Analysis	8
Precast Hollow Core Planks	8
Flat Plate	10
Systems Summary	11
Design Loads	12
Lateral System	13
Problem Statement	15
Proposed Solution	15
Breadth Topics	17
Graduate Course Integration	17
Tasks and Tools	18
Timeline	20
Conclusion	21

Executive Summary

The Mountain Hotel is a 40,000 square foot hotel located in urban Virginia. Its current gravity system employs precast hollow core planks resting on load bearing light-gage steel stud walls. The lateral system resists loads through use of light-gage stud walls with flat strap bracing and a combination of reinforced masonry and concrete shear walls. Presented in this document is a proposed subject of study within the field of structural engineering pertaining to the Mountain Hotel that is to be conducted during the spring semester. Two related architectural engineering breadths studies are also proposed.

The primary focus of this proposed thesis is to learn competency in seismically controlled concrete design. The thesis will investigate exchanging the various structural components for concrete as the primary construction medium. After review of the floor systems explored in Technical Assignment II, it was determined that a two-way flat-plate system was the best suited alternate system. The gravity and lateral load resisting systems will be redesigned within the new parameters. Once a preliminary plan is created, the Mountain Hotel will be designed allow for Immediate Occupancy in San Francisco, California following a seismic event in compliance with ASCE 41 drift and damage criteria. A baseline will determined using minimum requirements for life safety which will be used for comparison.

Two breadths will be integrated in to the design complementing the structural depth. In order to maintain comfort for the guests, a study will be performed to see if the changes to the structure have an adverse impact on sound isolation. Additional isolation materials will be added as required. The second breadth study will investigate the energy efficiency of the current glazing through means of heat transfer analysis. Alternate glazing will be selected to mitigate the building's energy consumption, and comply with ASCE 41 nonstructural performance requirements.

The graduate coursework incorporated into the proposed design consists of Advanced Computer Modeling and Earthquake Design. Thesis courses will be relied upon heavily throughout the project. An outline of tasks and tools, and a schedule showing an expected progress timeline are also incorporated at the end of this proposal.

Building Introduction

The new hotel is to be located in a wealthy urban area of Virginia (Location shown in Figure 4-1). The site chosen for construction of the new hotel is a prominent location previously occupied by a chain of parking lots, which border the main street of the town.



Figure 4-1
An aerial view from bing.com maps with the building superimposed on. Hotel is in Red, Garage in Yellow.

In order to match the new building into its surrounding architecture the first two floor facades are brick with large glazing panels, while the upper facade uses a palette of varying shades from brick red to white which enables it to match the brick and concrete of the surrounding buildings, including the adjacent concrete parking structure. However, in place of the brick or **concrete**, the **upper stories** of the hotel use a lighter more cost effective cladding, exterior insulation finishing system (EIFS) panels. The Porte Cochere on the west side, shown in Figure 4-2, will help funnel visitors into the main lobby where they can check-in and be directed to their rooms, other amenities, or sites of the town.

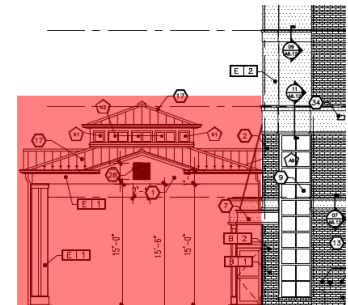

Figure 4-2
Porte Cochere attached to Hotel over main Entrance.

Guest rooms are located on the second through sixth floors totaling just over 40,000 square feet. Though the main function is to appease guests with a home away from home, it also contains meeting rooms for conferences, offices for hotel management, and a 40,000 square foot parking garage. Total building area is approximately 120,000 square feet.

Structural Overview

The hotel rests on reinforced concrete spread footings ranging from 12 to 42 inches in depth. Concrete piers transfer the load into the interior footings from the steel columns. The exterior concrete basement walls rest on strip footings, ranging from 12 to 24 inches, are load bearing and double as shear walls for the lateral system. A500 Grade B hollow structural steel ranging from four to 16 inches, longer dimension, is used for the superstructure columns. Some of the floors are supported by wide flange beams, ranging from W8 to W21, while others are resting on steel stud bearing walls as shown in

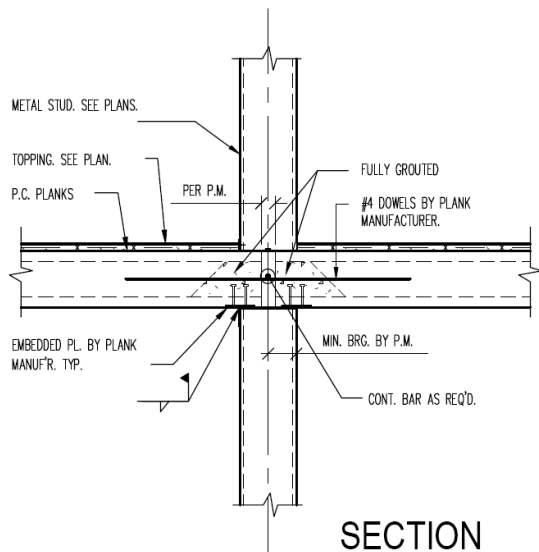

Figure 5-1
Hollow core plank ends spliced and resting on light gauge steel stud framed walls.

Figure 5-1. The lateral system employs a combination of reinforced concrete shear walls, specially reinforced masonry shear walls and light framed wall system with flat strap bracing extending from the ground floor to roof level in both the long and short directions. Floors ground through six are installed as a series of eight inch precast hollow-core planks ranging in length from 9' 2" to 25' 8". The roof is also built of four or eight inch hollow-core planks. Both the brick walls and EIFS system are attached to cold formed steel stud walls. The loading on the exterior facade is transferred through the wall framing to the floors and into

the lateral system.

The garage is also supported on reinforced concrete spread footings 12 to 30 inches in depth, and strip footers 12 to 24 inches in depth. Piers transfer the load into the footings from the columns and the walls rest directly on the strip footings. Piers and beams are poured monolithic with the walls.

Columns support two-way slabs and utilize drop panels, and edge beams.

Code Requirements

Standards and codes governing construction are as follows:

2009 ICC/ANSI A117.1

2009 International Building Code

2009 Virginia Uniform Statewide Building Code

2008 NEC – National Electric Code

2009 ICC – International Mechanical Code

2009 ICC – International Plumbing Code

2009 ICC – International Energy Conservation Code

- All concrete work shall be in accordance with ACI 301, ACI 318 and ACI 302 latest editions.
- All Masonry work shall be in accordance to: ACI 530/ASCE 5, “Building code requirements for Masonry structures”; ACI 530/ASCE 6, “specifications for masonry structures”
- Structural Steel Shall conform to the AISC “Specification for the design fabrication and erection of structural Steel for buildings”, Latest edition, except chapter 4.2.1, code of standard practice
- All light gauge framing shall conform to “the specification for the design of cold-formed steel structural members”, latest edition, by AISI
- All Wood framing shall conform to the “national design specification for wood construction” latest edition, published by the national forest products association,
- In addition to the requirements included in these structural notes, all construction and materials shall further conform to the applicable provisions of the following standards:
 1. American Society for Testing and Materials (ASTM)
 2. American Concrete Institute (ACI)
 3. National Concrete Masonry Association (NCMA)
 4. American Institute of Steel Construction (AISC)
 5. American Welding Society (AWS)
 6. American Iron and Steel Institute (AISI)
 7. Steel Structures Painting Council (SSPC)
 8. American Forest and Paper Association
 9. National Forest Products Association (NfoPA)

Governing the Parking Garage is all of the above with the inclusion of:

2006 International Building Code

2006 Virginia Uniform Statewide Building Code

Gravity System

Superstructure

This building uses several types of structural members to carry the various gravity induced loads to the earth. The hotel roof and all above grade floors utilize hollow core planks to support the dead loads of the structure as well as all the amenities people and other items. The planks typically rest on cold-formed steel stud shear walls which pass the load onto the floor below, and so on until it either reaches either a reinforced concrete shear wall or a wide flange beam which it can do so as high as the fourth floor, or as low as the first floor. W-shapes made to the ASTM standard A992 range in size from W6x15 to W33x130. ASTM A500 Hollow Structural Section (HSS), ranging from HSS 4x4x¼ HSS 12x12x½, columns hold the beams in place. Most of the HSS columns terminate in the lower floors; however there are several members that transfer load directly from the roof into the foundations. The Elevator and stair towers are an exception the typical framing types. They use specially reinforced masonry shear walls to resist both gravity and lateral loads stretching from above the normal roof height and down into the foundation.

Substructure

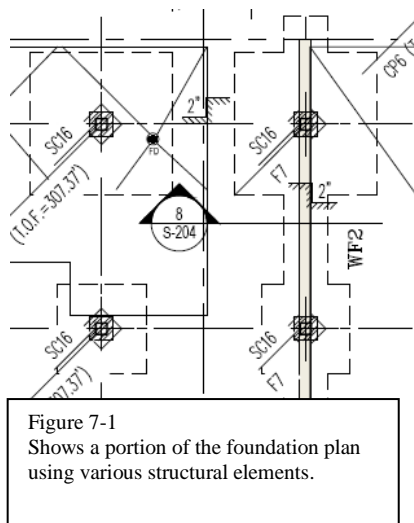

Figure 7-1
Shows a portion of the foundation plan
using various structural elements.

The substructure uses a series of reinforced concrete shear walls to transfer the loads from the superstructure into the wall footings of the foundation (Figure 7-1). Under columns and column piers, there is a series of spread footings the largest of which is 16"x16"x42" deep. Footings maintain a minimum compressive strength of 3000psi. Other concrete members have an F_c of 5000psi. Footings rest upon soil which has a bearing pressure of 3000psf.

Floor Systems Analysis

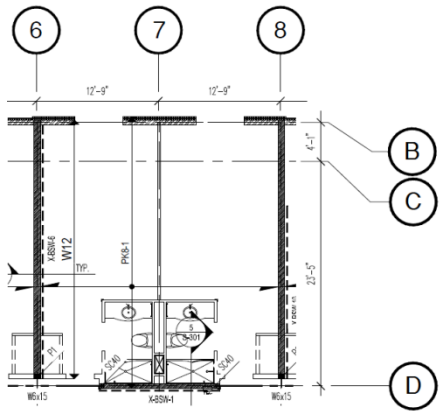

Figure 8-
Typical Bay of Sheet S-003
Column lines overlaid to show dimensions

Visual analysis of the plans reveals that a typical structural bay for the Mountain Hotel is 25' 6" x 27' 6". A typical bay was chosen between column lines 6 – 8 and D - E for comparative design and analysis (See Figure 8-1). The initial floor system was analyzed and compared to three proposed alternate systems for the Mountain Hotel. All systems were designed and evaluated solely under gravity load. The floor systems considered are: Precast Hollow Core Planks, Composite Deck on Wide Flange Beams, One-way Joist Beam System, and Flat Plate. Each floor system is detailed in its

respective section noting advantages and disadvantages. Systems were evaluated based on: fire protection, durability, weight, susceptibility to vibration, cost (Costs data was obtained from RS Means Costworks Online database, tables located in Appendix G), depth, constructability, and aesthetic. A summary comparing the four floor systems can be found in Table 11-1. Calculations pertaining to the designs can be found in the appendices.

Precast Hollow Core Planks

Description:

The existing floor system used in all of the above grade floors of the Mountain Hotel is comprised of pre-stressed pre-cast hollow core planks spanning up to 25' 6" and rest on pre-engineered light gauge metal stud shear walls, which transfer the load via steel angles which are imbedded into the planks prior to casting. The exterior plank sticks past the centerline of the exterior support six inches (a three inch cantilever can be seen in the detail shown in Figure 8-1) in order to conform to the four foot module. The floor planks have a one inch gypcrete topping to tie the planks together and produce a continuous surface. The total thickness of the floor system is ten inches.

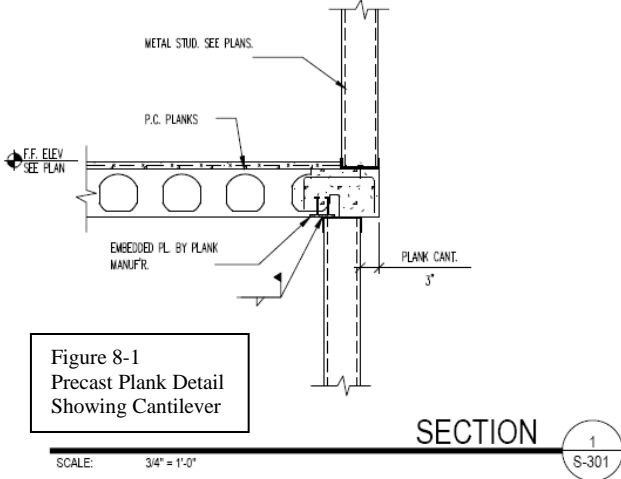

Figure 8-1
Precast Plank Detail
Showing Cantilever

Advantages:

Precast Hollow Core Planks on light gauge bearing walls are a very efficient choice by almost every metric. It was the cheapest of all the options considered by over two dollars per square foot. The precast planks make construction quick and simple as planks only have to be lifted and set in place once they arrive at the site. Gravity and lateral elements and foundations can be designed using smaller members due to the low unit weight of the hollow core planks. These post-tensioned elements are able to carry significant load over large spans while taking up minimal floor cavity space and still maintaining fire rating criteria. The flat underside gives them the ability to double as an architectural ceiling.

Disadvantages:

Erection time is fast once the planks arrive on site, however the lead time to create the planks could create significant delays on a project, if not ordered within enough advance. Long pieces can have the potential to create problems for a tight site. Though it is possible to create planks in any width, a standard module size generally limits the bay sizes to multiples of four feet. Ability for thin floor systems also opens up vulnerability for issues with vibration, and sound isolation. Due to the lower lateral stiffness of the light gauge walls and the relatively higher weight of the concrete planks this system does not resist seismic forces particularly well.

Flat Plate

Description:

Flat Plate (depicted in Figure 10-1) is a two-way concrete system designed to more efficiently utilize the concrete strength and limit the impact resulting from the thickness of a floor cavity. The depth was determined using the shear capacity of the slab without the aid of shear reinforcement, but deflection criteria in Table 9.5(c) ultimately controlled. A stipulation to use a flat plate would also require a redesign of the gravity and lateral systems with concrete columns and shear walls. The second row of central columns was also eliminated here in order to simplify design and to create a more uniform system. The larger bay was considered.

Figure 10-1
Flat Plate as Depicted by RSMMeans

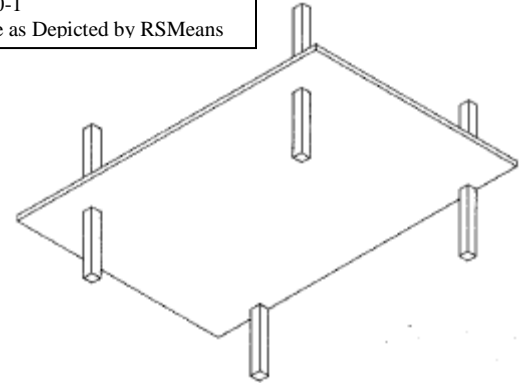

TABLE 9.5(c)—MINIMUM THICKNESS OF SLABS WITHOUT INTERIOR BEAMS*

f_y , psi†	Without drop panels‡				With drop panels‡	
	Exterior panels		Interior panels	Exterior panels	Interior panels	
	Without edge beams	With edge beams§		Without edge beams	With edge beams§	
40,000	$\ell_n/33$	$\ell_n/36$	$\ell_n/36$	$\ell_n/36$	$\ell_n/40$	$\ell_n/40$
60,000	$\ell_n/30$	$\ell_n/33$	$\ell_n/33$	$\ell_n/33$	$\ell_n/36$	$\ell_n/36$
75,000	$\ell_n/28$	$\ell_n/31$	$\ell_n/31$	$\ell_n/31$	$\ell_n/34$	$\ell_n/34$

†For two-way construction, ℓ_n is the length of clear span in the long direction, measured face-to-face of supports in slabs without beams and face-to-face of beams or other supports in other cases.
 ‡For f_y between the values given in the table, minimum thickness shall be determined by linear interpolation.
 §Drop panels as defined in 13.2.5.
 ¶Slabs with beams between columns along exterior edges. The value of α_f for the edge beam shall not be less than 0.8.

Advantages:

This two-way system is very good at reducing the overall thickness compared to a one-way slab. Because of the flat underside of the slab there would be no adverse effect to the architectural ceiling. Flat plates have simple formwork and combined with the relative thickness results in a low cost solution. The concrete mass will provide good resistance to vibrations and deflections, and will have increased damping to combat seismic forces.

Disadvantages:

Compared to the existing, foundations would have to be designed for a much greater load. Flat plate are the most complicated to design of the proposed systems due to the complicated three dimensional load path. As a result, they are not very flexible for future design alterations.

Systems Summary

The chart provided below Figure 11-1 is a simple summary overviewing the strengths and weaknesses of the four systems previously described. The final row is based on a personal opinion about whether the system is worthwhile to implement as an alternative floor design with reasons listed if it has been determined that a system should be excluded from consideration.

Table 11-1 Systems Summary	Systems			
	Existing	Alternatives		
Consideration	Precast Hollow Core Planks	Composit Steel Deck on W-Shapes on Shear Walls	One-way Concrete Joist System	Two-way Flat Plate
General Information				
Weight	57 psf	66.8 psf	79.5 psf	118 psf
Fire Rating	2-Hr	2-Hr	2-Hr	2-Hr
Fire Protection	Thickness of Planks Adequate for Fire Protection	Requires Additional Fireproofing for underside of Deck and Beams	Thickness of Slab Controlled by Fire Protection Criteria	Thickness of Slab Adequate for Fire Protection
Architectural				
Bay Size	25' 6" x 27' 6"	25' 6" x 27' 6"	25' 6" x 33' 0"	25' 6" x 33' 0"
Overall Depth	10"	14"	22"	9.5"
Slab Depth	10"	6"	5"	9.5"
Ceiling Height	8' 6"	8' 2"	8' 11"	8' 6.5"
Other	Exposed Ceilings	Requires a Ceiling	Can Expose Ceilings for Queen Rooms Only Without Obstructions	Exposed Ceilings
Structural				
Gravity System Considerations	No Change	Special Considerations for Attachment of Beams to Walls	Redesign using Concrete Columns	Redesign using Concrete Columns
Lateral System Considerations	No Change	No Change	Redesign using Concrete Moment Frames	Change From Light Gauge to Concrete Shear Walls
Foundation Considerations	No Change	Very Similar	Increase Foundation Size to Carry Larger Building Weight	Increase Foundation Size to Carry Larger Building Weight
Construction				
Assembly Cost	\$13.23/sf	\$23.9/sf	\$15.78/sf	\$15.24/sf
Formwork Required	None	Minimal	Yes	Yes
Constructability	Easy	Slightly Moderate	Slightly Difficult	Moderate
Lead Time	Long	Moderate	Moderate	Moderate
Servicability				
Vibration and Deflection Control	Slightly Moderate	Moderate	Great	Good
Feasible				
Feasible	Yes	No	No	Yes
Reason		Significant increase in price, requires a ceiling, reduces ceiling height	King and ADA Rooms would have a low ceiling height due to 22" deep beam in center of ceiling	

Design Loads

Load Combinations

Listed here are all the load combinations that are being considered. All load combinations are based on LRFD and come from ASCE 7-10.

- 1.4D
- 1.2D + 1.6L + 0.5(Lr or S or R)
- 1.2D + 1.6(Lr or S or R) + (L or 0.5W)
- 1.2D + 1.0W + L + 0.5(Lr or S or R)
- 1.2D + 1.0E + L + 0.2S
- 0.9D + 1.0W
- 0.9D + 1.0E

Deflection Criteria

Typical Live Load Deflection Limit: $L/480$

Typical Total Load Deflection Limit: $L/360$

Drift Criteria

Allowable Building Drift limit: $(L \text{ or } H)/400$

Inter-story Drift

Wind: $(L \text{ or } H)/400$ to $(L \text{ or } H)/600$

Seismic: $.020 \times h_{xx}$

Lateral System

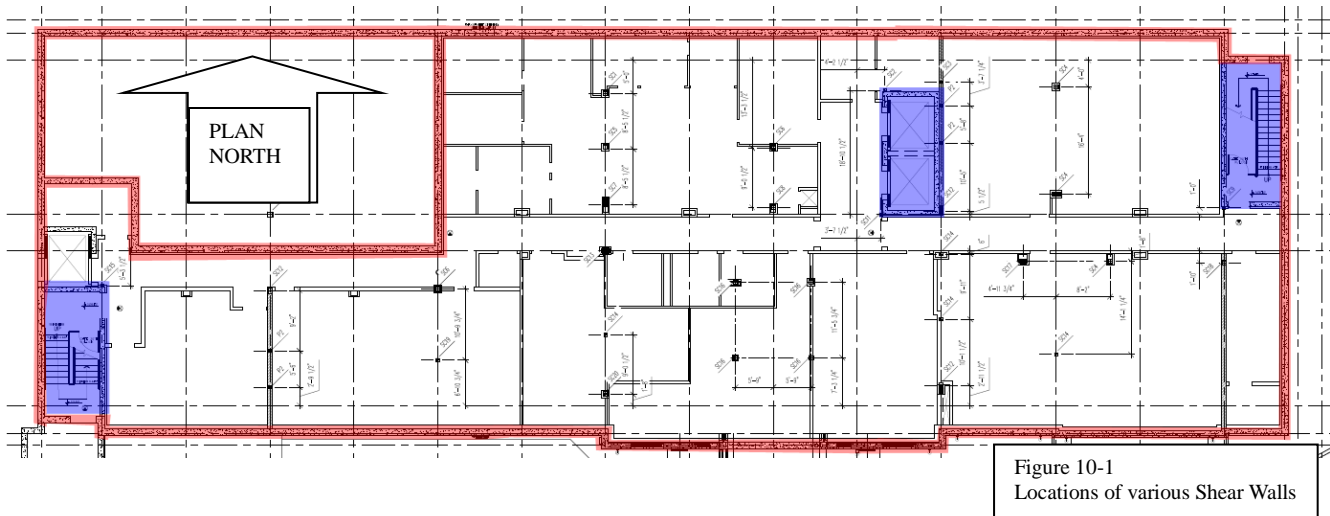

Figure 10-1
Locations of various Shear Walls

Lateral forces in the Mountain Hotel are resisted mainly by three different types of elements. Below grade, lateral forces are resisted through a system of reinforced concrete shear walls some of which are highlighted in red in Figure 10-1. The exterior walls are 14 inches in thickness while most of the interior walls are eight inches thick. A few of these walls extend up to the second story, but most of the superstructure employs cold-formed steel stud walls with flat strap bracing to resist wind and earthquake loadings. Braced walls are shown in Figure 10-2 and are highlighted in yellow. In the design of the light gauge elements the structural engineer specified locations, possible member sizes and what forces these elements were required to resist. However, it is expected that the

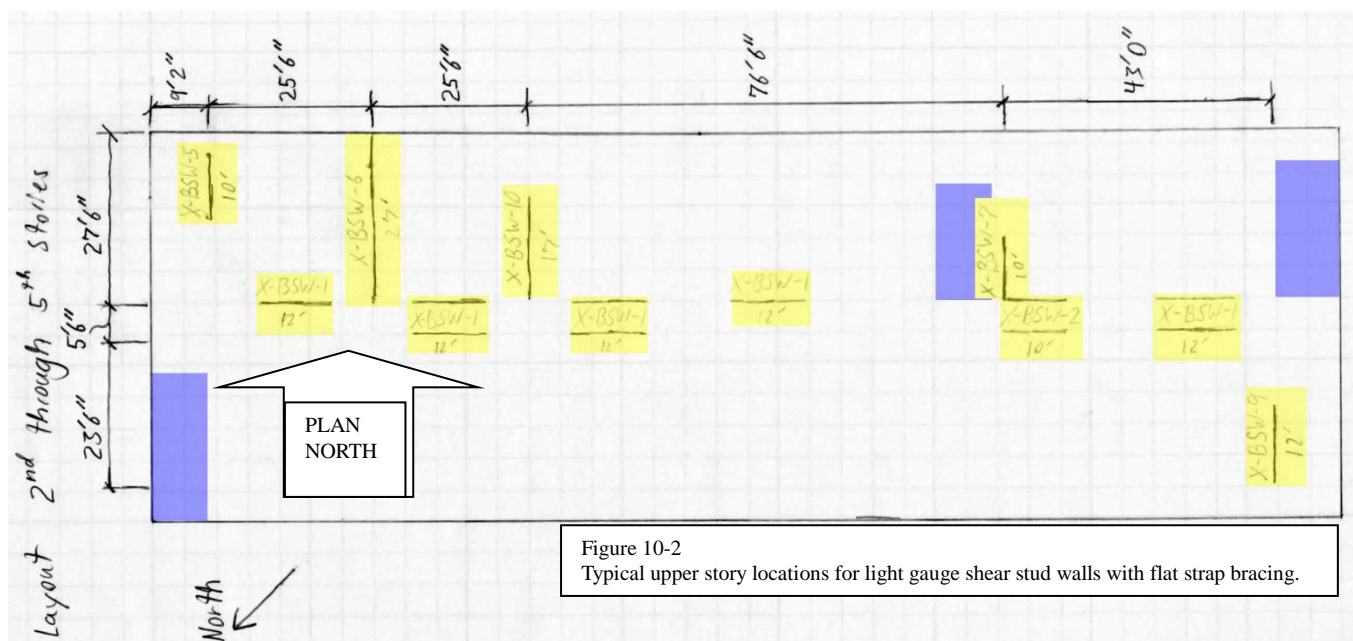
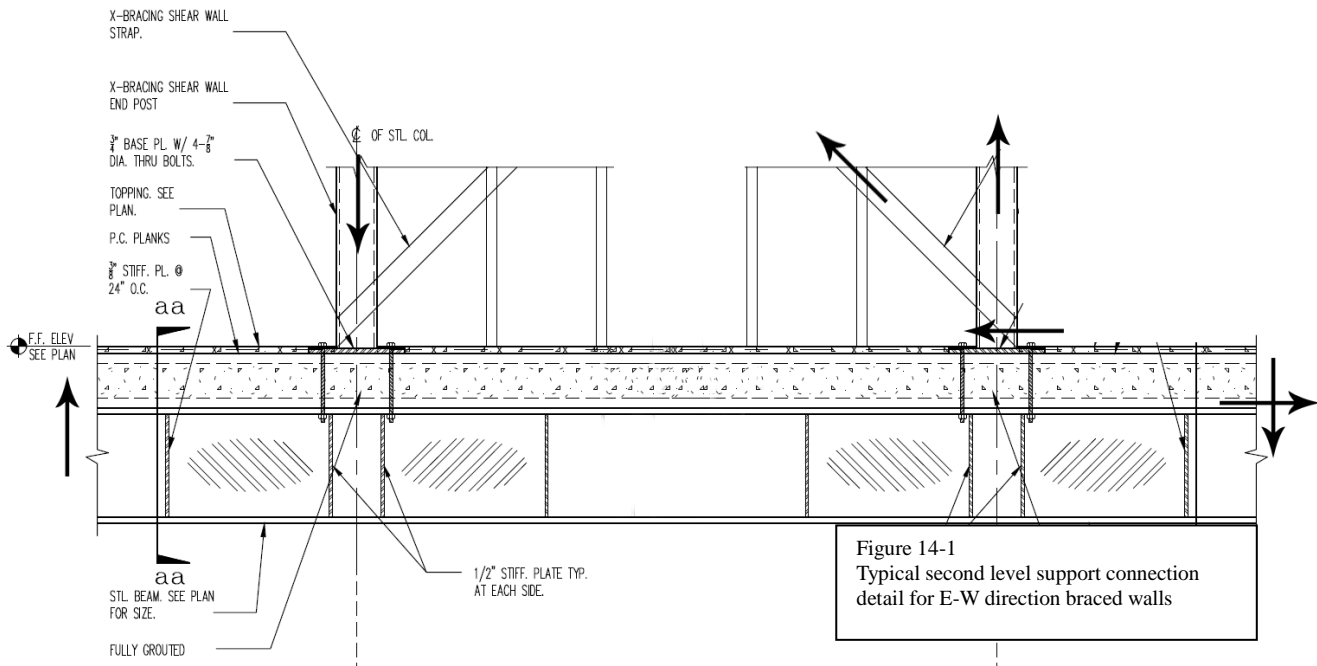

Figure 10-2
Typical upper story locations for light gauge shear stud walls with flat strap bracing.

light gauge provider size the individual members. In order to fully analyze the lateral system stiffness, straps were sized from the Marinoware cold formed steel framing system catalogue, to resist the forces specified in the drawings.

The elevator and two stair towers also contain specially reinforced masonry shear walls to resist forces in both the building's dimensions. Stair and Elevator tower locations are shaded in blue. A horizontal out of plane irregularity exists at the second floor under the E-W frames. A typical distribution of moment to the supporting beam is shown in Figure 14-1.



Problem Statement

The in-depth lateral systems analysis performed in Technical Report III showed that the lateral system of the current structure is more than adequate in supporting the controlling seismic load case. As an academic exercise, the Mountain Hotel will be converted to concrete and relocated to a location in a higher seismic region. After moving the Hotel to San Francisco, California, the lateral system must be redesigned to work with increased seismic loading and more stringent seismic design codes.

Due to the increased likelihood of a seismic event and the owners desire to continue operations, The Hotel is to be designed for Immediate Occupancy. A cost benefit analysis study is to be performed for designing the Hotel for Immediate Occupancy over the standard design requirements for Life Safety.

Proposed Solution

It was ultimately ruled through a pro vs. con comparison, that the two-way flat-plate system was the most feasible substitute to the existing precast hollow core plank system. It was determined that this option was the least impeding on the architectural layout and style of the building.

The proposed thesis is to move the Mountain Hotel to San Francisco, California and redesign it using a two-way flat-plate reinforced concrete system. Changing the construction medium to concrete will require a complete overhaul of the Hotel's gravity and lateral force resisting systems. Rectangular reinforced concrete columns will carry the load of the existing cold-formed load bearing walls, while reinforced concrete shear walls will replace the flat strap bracing. Locations of columns and shear walls must coordinate with the existing building layout. The conversion to concrete will significantly increase the mass and orientation of the structure leading to a redesign of the foundation system.

The new structure for the Mountain Hotel will be designed for Immediate Occupancy (S-1) as defined by ASCE 41 drift and damage criteria (requirements can be found in Figure 16-1 taken from FEMA 356). Key components of the structure will also be designed only for Life Safety (S-3) in order to create a basis for comparison.

Table C1-3 Structural Performance Levels and Damage^{1, 2, 3}—Vertical Elements

Elements	Type	Structural Performance Levels		
		Collapse Prevention S-5	Life Safety S-3	Immediate Occupancy S-1
Concrete Frames	Primary	Extensive cracking and hinge formation in ductile elements. Limited cracking and/or splice failure in some nonductile columns. Severe damage in short columns.	Extensive damage to beams. Spalling of cover and shear cracking (<1/8" width) for ductile columns. Minor spalling in nonductile columns. Joint cracks <1/8" wide.	Minor hairline cracking. Limited yielding possible at a few locations. No crushing (strains below 0.003).
	Secondary	Extensive spalling in columns (limited shortening) and beams. Severe joint damage. Some reinforcing buckled.	Extensive cracking and hinge formation in ductile elements. Limited cracking and/or splice failure in some nonductile columns. Severe damage in short columns.	Minor spalling in a few places in ductile columns and beams. Flexural cracking in beams and columns. Shear cracking in joints <1/16" width.
	Drift	4% transient or permanent	2% transient; 1% permanent	1% transient; negligible permanent
Concrete Walls	Primary	Major flexural and shear cracks and voids. Sliding at joints. Extensive crushing and buckling of reinforcement. Failure around openings. Severe boundary element damage. Coupling beams shattered and virtually disintegrated.	Some boundary element stress, including limited buckling of reinforcement. Some sliding at joints. Damage around openings. Some crushing and flexural cracking. Coupling beams: extensive shear and flexural cracks; some crushing, but concrete generally remains in place.	Minor hairline cracking of walls, <1/16" wide. Coupling beams experience cracking <1/8" width.
	Secondary	Panels shattered and virtually disintegrated.	Major flexural and shear cracks. Sliding at joints. Extensive crushing. Failure around openings. Severe boundary element damage. Coupling beams shattered and virtually disintegrated.	Minor hairline cracking of walls. Some evidence of sliding at construction joints. Coupling beams experience cracks <1/8" width. Minor spalling.
	Drift	2% transient or permanent	1% transient; 0.5% permanent	0.5% transient; negligible permanent

Figure 16-1 Comparison of performance requirements for different Structural Performance Levels for Concrete Walls and Columns found in ASCE 41 taken from FEMA 356.

Table C1-5 Nonstructural Performance Levels and Damage¹—Architectural Components

Component	Nonstructural Performance Levels			
	Hazards Reduced ² N-D	Life Safety N-C	Immediate Occupancy N-B	Operational N-A
Glazing	General shattered glass and distorted frames in unoccupied areas. Extensive cracked glass; little broken glass in occupied areas.	Extensive cracked glass; little broken glass.	Some cracked panes; none broken.	Some cracked panes; none broken.

Figure 16-2 Comparison of performance requirements for Nonstructural Performance Levels for Glazing found in ASCE 41 taken from FEMA 356.

Breadth Topics

Acoustics – Sound Isolation

The first breadth topic will be to look at a single hotel room and study the impact of the change in structural material to concrete, to see if the sound isolation has become an issue. If sound isolation is a problem then the walls and floors will be designed to reduce it to proper levels.

Mechanical – Façade Study

The second breadth topic will evaluate the added thermal load by transmission through the glazing as a result of moving the Mountain Hotel to San Francisco. If the difference is significant, new glazing will be chosen to reduce the thermal load to that of the buildings original location. The new glazing will be designed to ASCE 41 standards for Immediate Occupancy (N-B) in order to supplement the depth design (requirements can be found in Figure 16-2 taken from FEMA 356)

Graduate Course Integration

When looking at the lateral system in ETABS advanced modeling techniques will be used to gain more accurate results. The models will use rigid and semi-rigid diaphragms. Shear walls will be modeled using area elements, and columns will be modeled using line elements. The lateral force analysis will consider inherent torsion, accidental torsion, and P-Delta effects.

AE 538 – Earthquake Resistant Design will be relied on heavily for this study, as the design of concrete structures for seismic applications was first taught in this class. Design for immediate occupancy was also introduced here.

Tasks and Tools

1. Structural Depth
 - a. Gravity System
 - i. Obtain a soils report for the new site conditions
 - ii. Check ASCE 7-10 for dead and live load changes
 - iii. Determine the layout for columns
 - iv. Determine required thickness of slab for strength and fireproofing in accordance with ACI 318-11
 - v. Size gravity columns and determine rebar placement for loads in accordance with ACI 318-11
 - vi. Determine loads transferred to the foundation
 - b. Lateral System
 - i. Research requirements to design for Immediate Occupancy according to ASCE 41
 - ii. Use ASCE 7-10 to determine the wind and earthquake loads
 - iii. Use ASCE 41 to determine additional requirements for Immediate Occupancy
 - iv. Determine locations for placement of shear walls
 - v. Determine the load distribution of the shear walls
 - vi. Determine wall thicknesses and required upsizing of lateral columns in accordance with ACI 318-11
 - vii. Determine rebar placement of remaining elements
 - viii. Determine additional loads transferred to the foundation
 - ix. Size Foundations according to ACI 318-11
 - x. Create an ETABS model to check and optimize design
2. Breadth Topics
 - a. Acoustics
 - i. Research noise criteria requirements for hotel rooms
 - ii. Determine the sound isolation provided by both systems
 - iii. Research materials needed for proper sound isolation

- iv. Determine placements of materials
- v. Determine architectural Limitations
- b. Mechanical
 - i. Research the solar conditions for each location
 - ii. Research existing glazing and determine thermal load contribution
 - iii. Compare thermal load using existing glass in both locations
 - iv. Research alternate glazing
 - v. Choose alternate glazing to reduce thermal load to established levels

Timeline

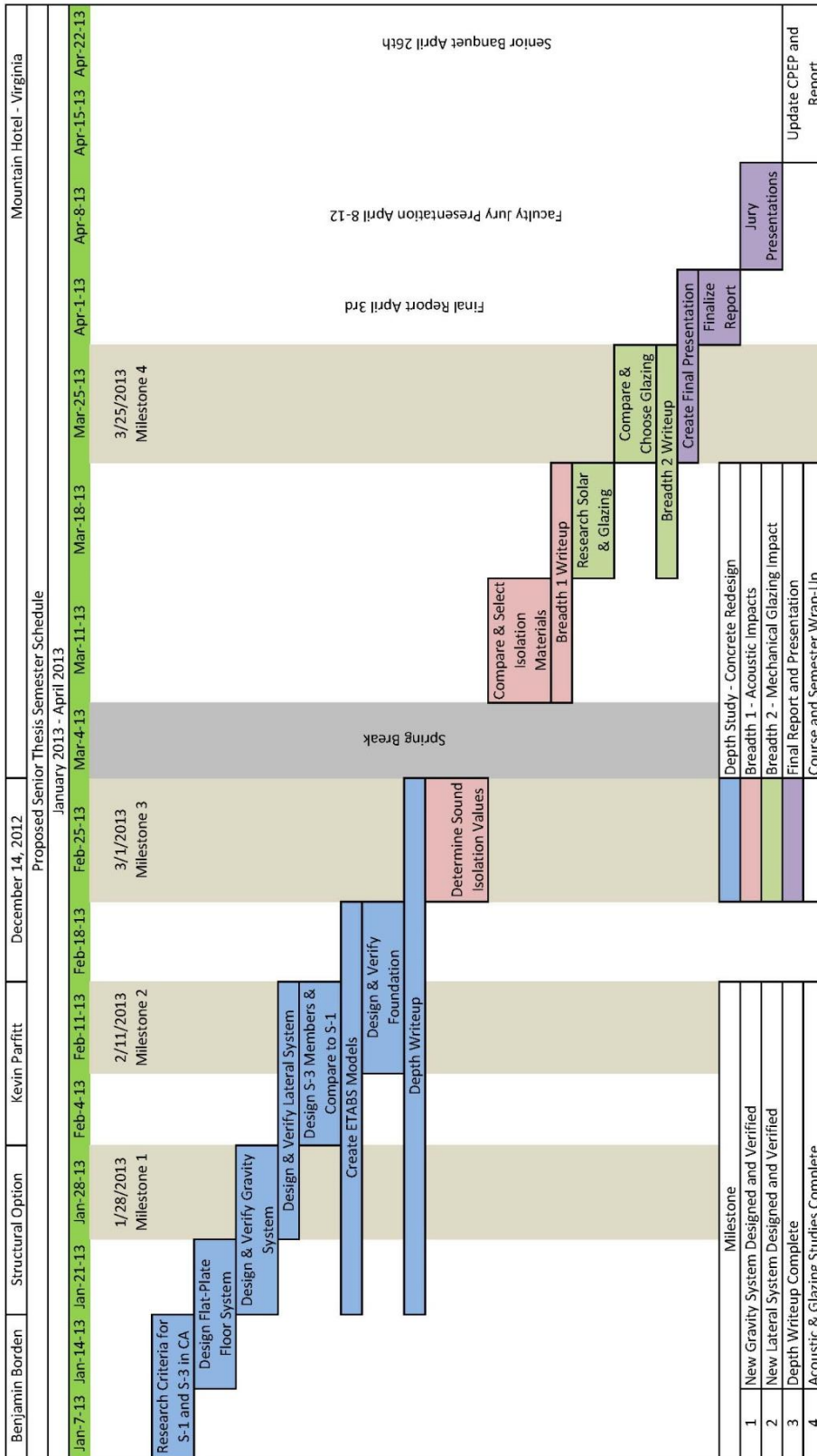

Conclusion

Proposed thesis work for the spring semester will focus on redesigning the structural system of the Mountain Hotel in San Francisco, California, utilizing cast in place reinforced concrete rather than the existing masonry, light-gage steel, and precast planks. The gravity and lateral systems will be reconfigured based on the new construction medium. Of the three systems examined in Technical Assignment II, it was determined that the two-way flat-plate floor system was the least intrusive alternative to replace the existing precast hollow core planks. Once a preliminary plan is created the Mountain Hotel will be designed allow for Immediate Occupancy following a seismic event, in compliance with ASCE 41 drift and damage criteria. Following the lateral and gravity systems, the existing foundation shall be redesigned to accommodate the new loads.

It is desired that the alterations to Mountain Hotel do not reduce the comfort of guests. Therefore the first breadth study topic will explore the impact the change in structure will have on acoustic isolation. The second breadth analyzing heat transfer and energy efficiency of the south facing glazing aimed at energy efficiency, while establishing a seismic resistant assembly to aid in performance redesign.